

# ELGEE POWER-VAC



OWNER'S MANUAL

## **Congratulations on your purchase of an Elgee Power-Vac!**

Your new machine is the perfect solution for debris and litter control at factories, warehouses, stables, sports arenas, amusement parks, and countless other facilities. The Power-Vac's ability to clean up to 40,000 square feet per hour will save you time and money!

# **CONTENTS**

Assembling the Power-Vac . . . . .	2
Handle Assembly . . . . .	4
Dolly Installation . . . . .	6
Deflector Installation . . . . .	7
Filter Bag Installation . . . . .	8
Hose Assembly and Installation . . . . .	9
Using the Optional Hose . . . . .	13
Maintaining your Power-Vac . . . . .	14
Additional Resources and Contact Information . . . . .	15
Elgee Power-Vac Limited Warranty . . . . .	16

**This Manual is applicable to all gasoline-fueled Power-Vac models:**

632-G, 632-GH, 633-G, 633-GH, 634-G, 634-GH, 642-G, 642-GH, 643-G, 643-GH, 644-G, 644-GH, 1032-G, 1033-G, 1034-G, 1042-G, 1043-G, 1044-G

# ASSEMBLING THE POWER-VAC

Assembling your new *Elgee Power-Vac* is a snap. Just follow the instructions on the next few pages and you'll be up and running in no time!

Below is an exploded view showing the main components to be assembled. The hardware that is used is detailed on the next page.

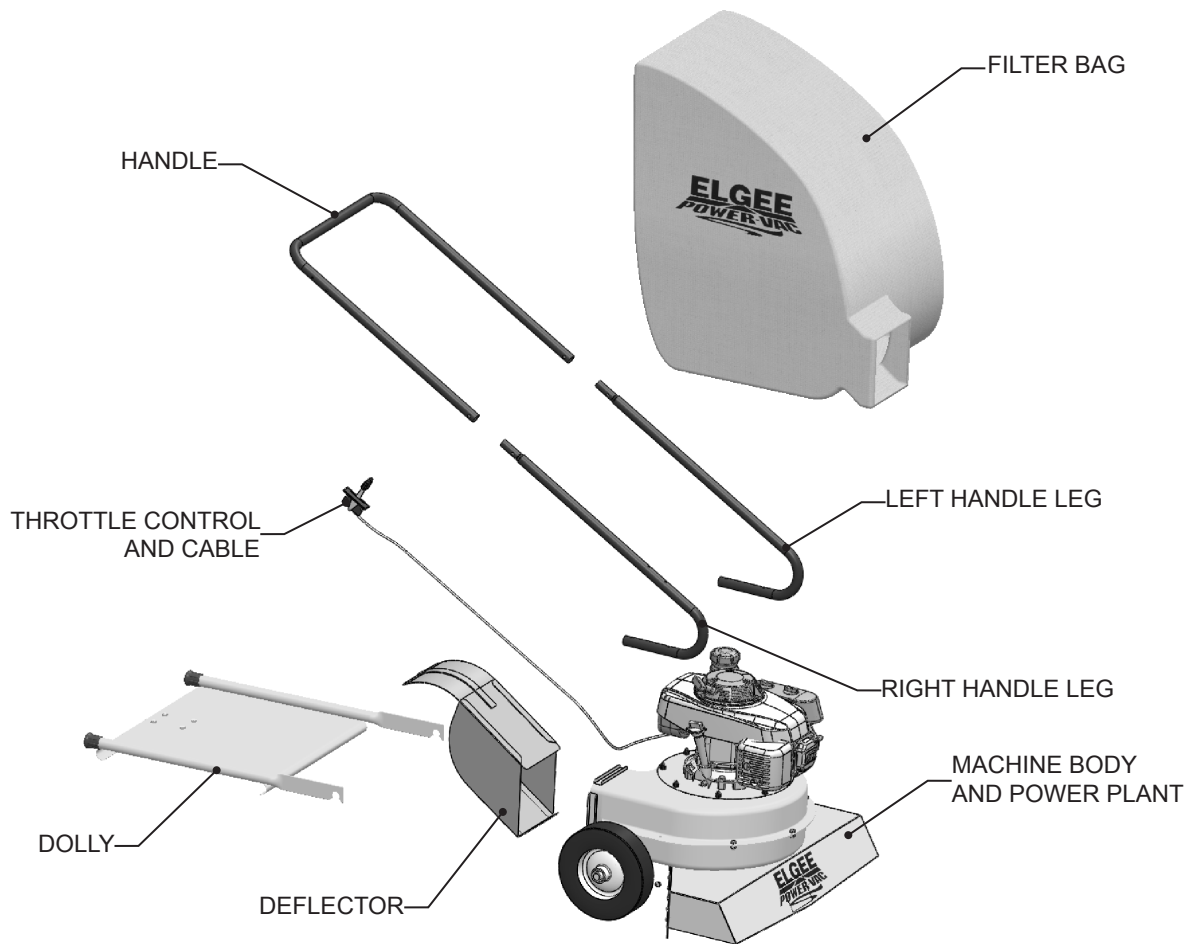

## You'll need just a few tools . . .

- Ratchet wrench with 1/2" socket and extension
- 1/2" Open end wrench
- 3/8" Open end wrench
- #2 Phillips screwdriver
- Rubber mallet

## All the hardware you'll need is provided . . .



5/16" x 1-1/2" Hex Head Screw (4)

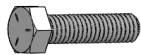

5/16" x 1-1/4" Hex Head Screw (2)



#10 x 1-1/4" Phillips Head Screw (2)



5/16" Flat Washer (4)



5/16" Lock Washer (2)



#10 Lock Washer (2)



5/16" Hex Nut (2)



5/16" Locking Hex Nut (has an embedded nylon ring on one side) (4)



#10 Hex Nut (2)



Cable Clip (2)

# HANDLE ASSEMBLY

1. Attach the **Left and Right Handle Legs** to the machine body. NOTE: The **Right Handle Leg** has five holes and goes on the right side of the machine (when viewed from the operator's position); the **Left Handle Leg** has only three holes and goes on the left side. For each leg, use two hex-head machine screws, flat washers, and locking hex nuts as shown in the illustrations below.

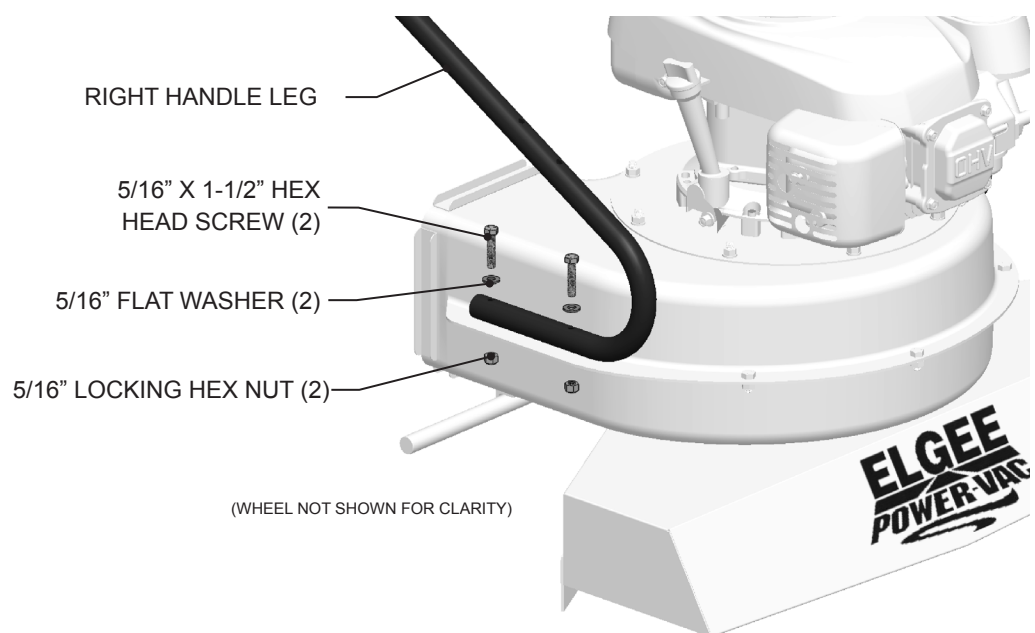
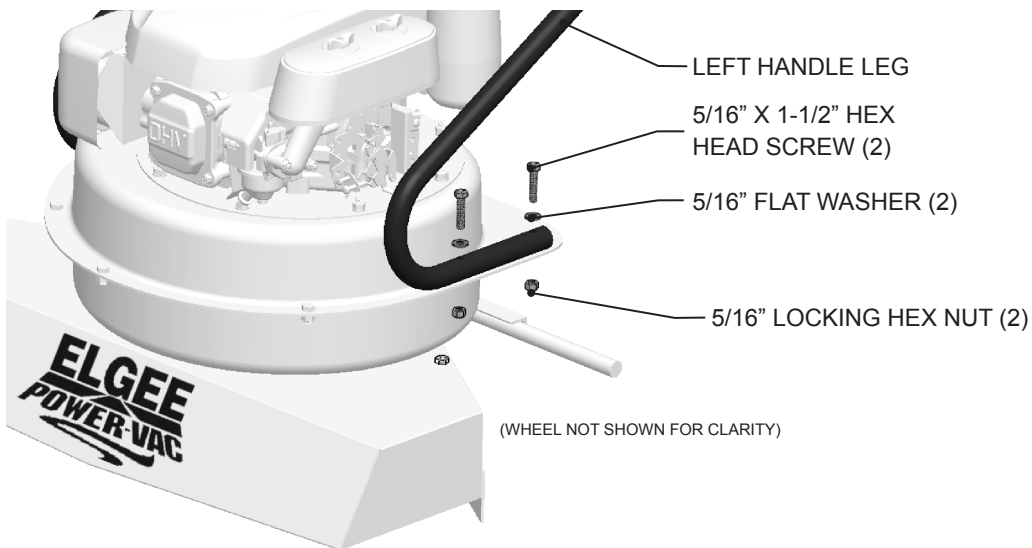

- 2.** Slide the **Handle** onto the **Right and Left Handle Legs** and attach with two hex-head machine screws, flat washers, and hex nuts as shown in the illustration. The two holes nearest the bend must be on the right side of the machine when viewed from the operator's position.

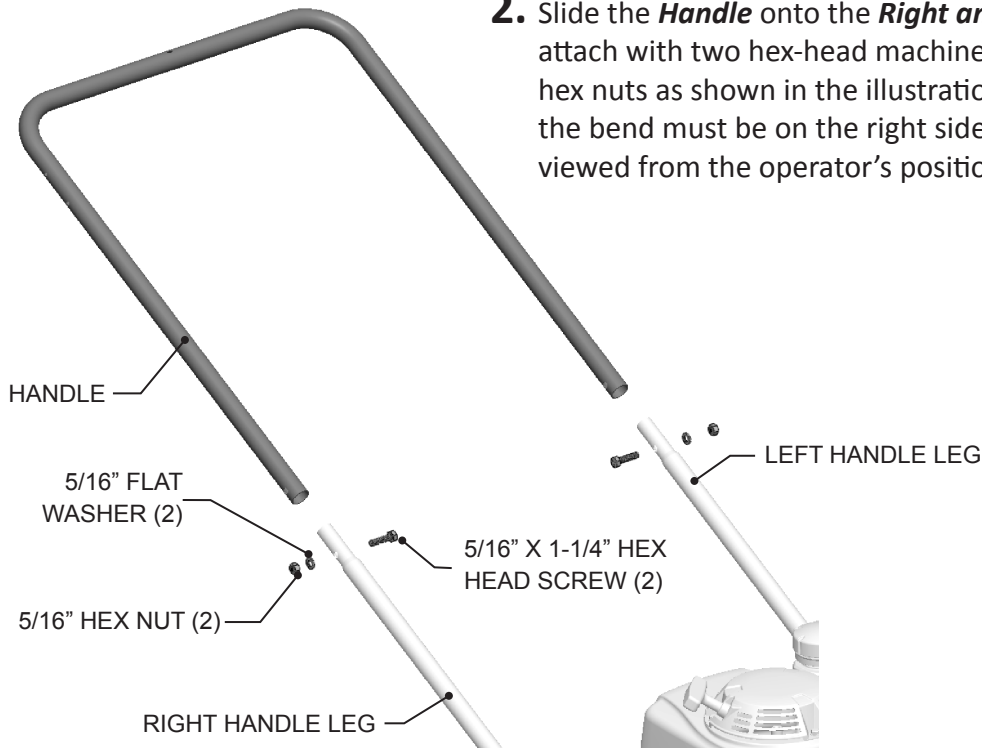

- 3.** Attach the **Throttle Control** to the **Handle** with Phillips head screws, lock washers, and nuts. Use the two holes in the **Handle** closest to the bend.

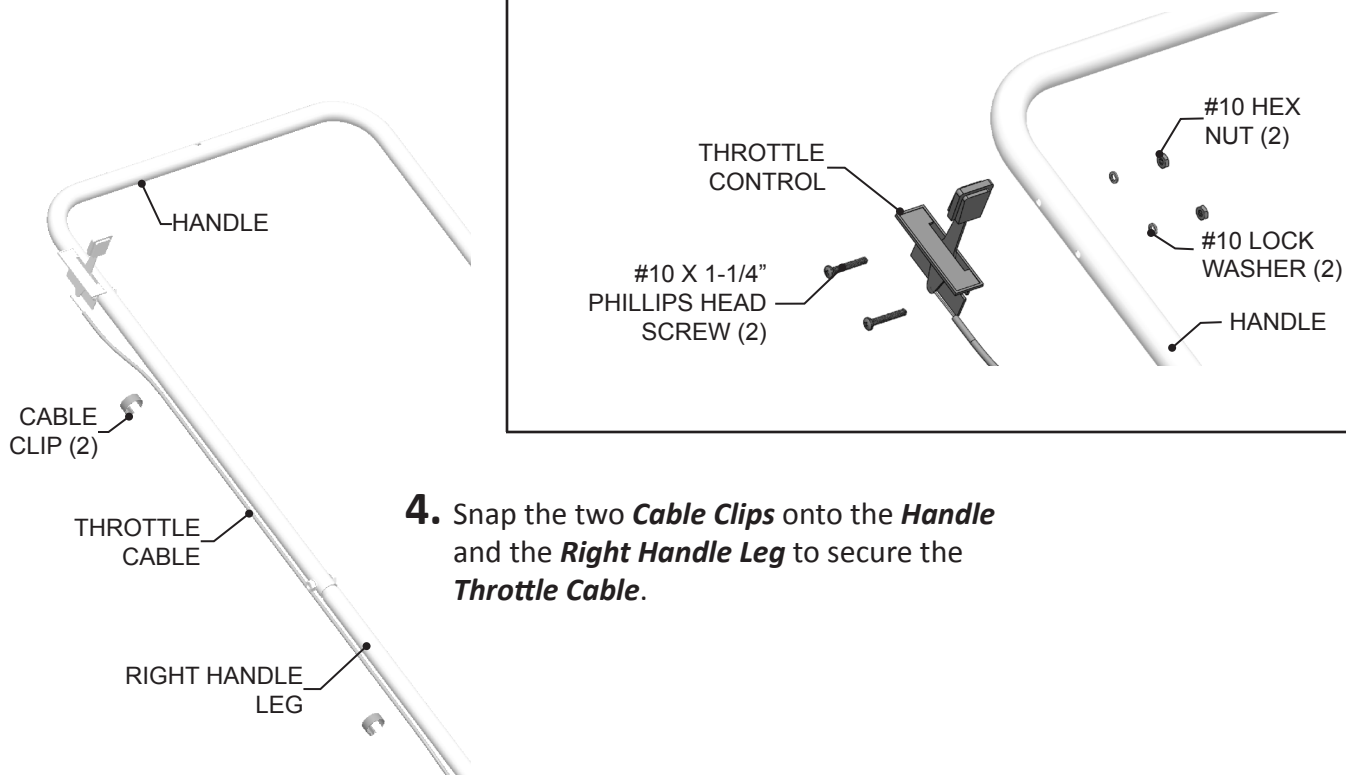

- 4.** Snap the two **Cable Clips** onto the **Handle** and the **Right Handle Leg** to secure the **Throttle Cable**.

# DOLLY INSTALLATION

- 1. Line up the half hole of the *Dolly* with the machine's *Axle*.
- 2. Strike the *Dolly* above the hole with a rubber mallet to snap it into place.

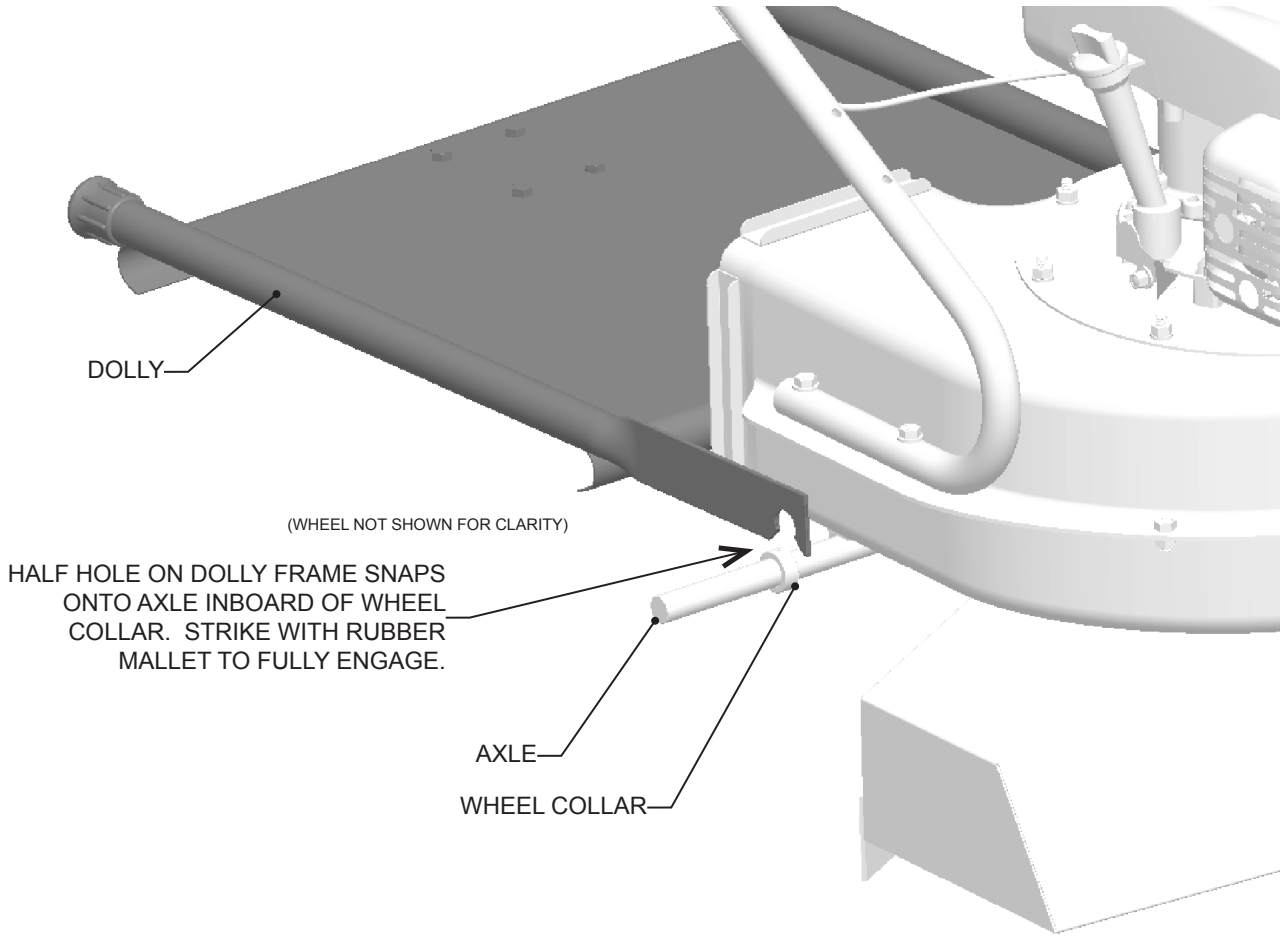

# DEFLECTOR INSTALLATION

1. Position the **Deflector** towards the inside of the machine so that its top and bottom lips will engage the channels on the discharge chute.
2. Use a rubber mallet to force the **Deflector** outward until it is centered on the discharge chute.

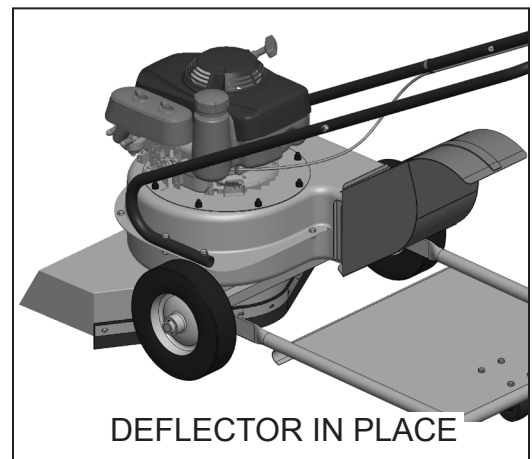
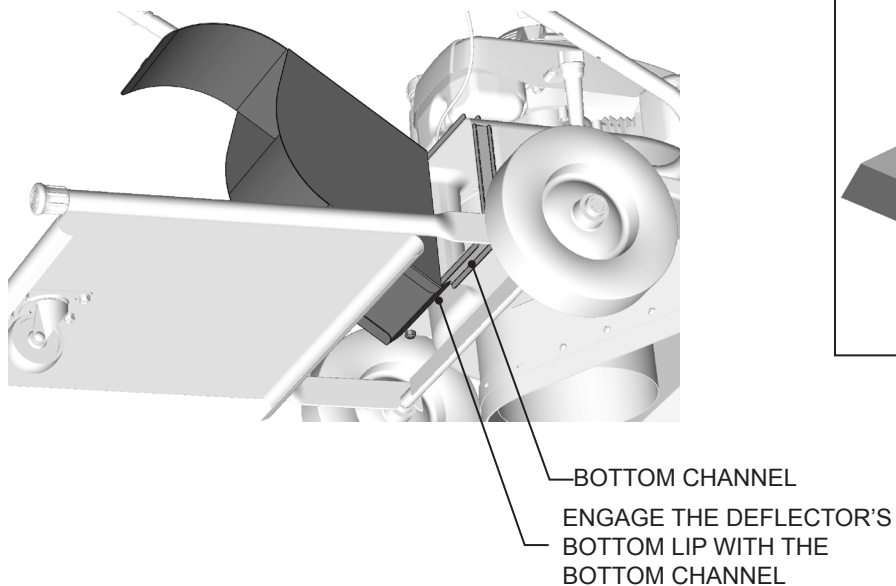
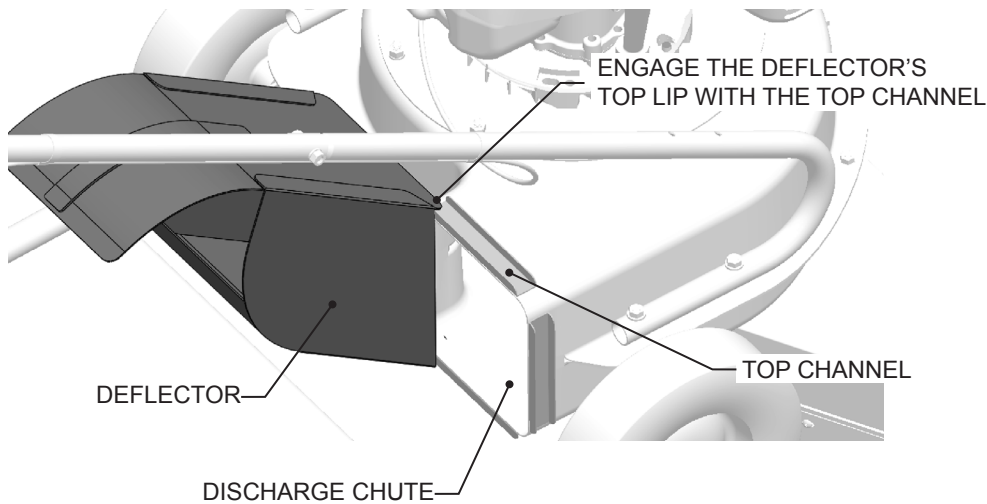

**NEVER OPERATE THE MACHINE WITHOUT THE DEFLECTOR IN PLACE.**

# FILTER BAG INSTALLATION

1. Place the neck of the **Filter Bag** over the **Deflector** so that it covers the channels on the machine's discharge outlet.



2. Cinch the **Filter Bag's** built-in strap to secure its neck.



3. Loop each pair of the **Filter Bag's** handle straps around the **Handle** and fasten the metal clasps to join them.



**NEVER OPERATE THE MACHINE WITHOUT THE FILTER BAG IN PLACE.**

**EMPTY THE FILTER BAG IMMEDIATELY AFTER EACH USE.**

# HOSE ASSEMBLY AND INSTALLATION (OPTIONAL)

The next few pages describe the assembly, installation, and use of the optional *Power-Vac Hose*. **Skip ahead to page 14 if you have not purchased this accessory.** Below is an exploded view showing the parts included with the kit.

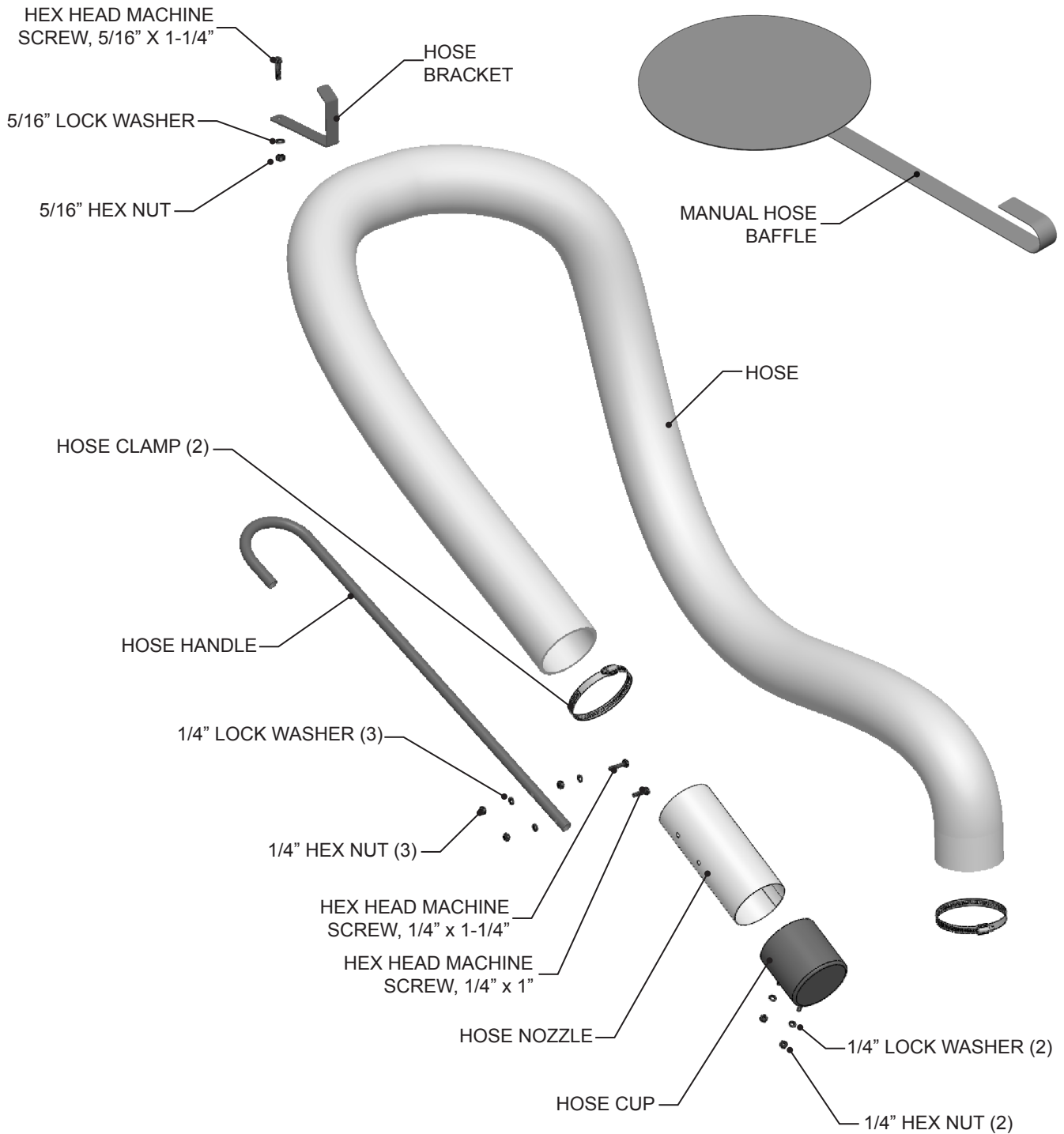

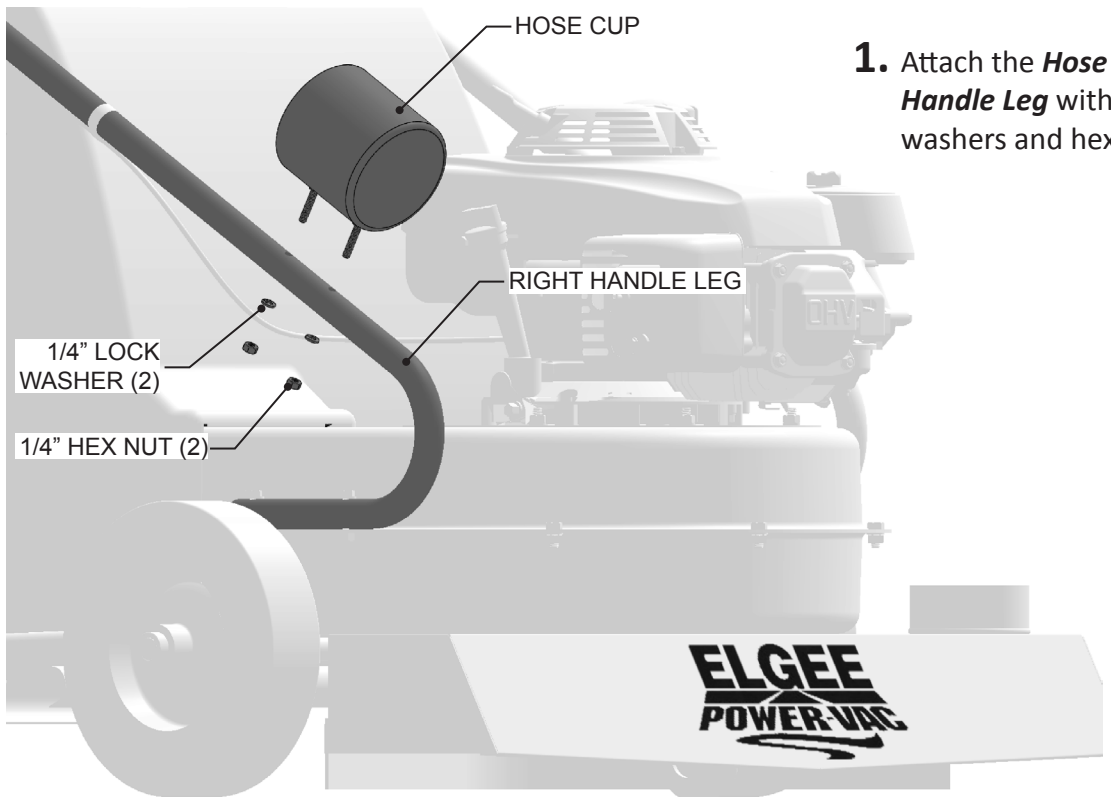

**1.** Attach the *Hose Cup* to the *Right Handle Leg* with two 1/4" lock washers and hex nuts.

1/4" LOCK WASHER (2)  
1/4" HEX NUT (2)

HOSE CUP  
RIGHT HANDLE LEG

**ELGEE**  
**POWER-VAC**

**2.** Attach the *Hose Bracket* to the *Handle* with a 5/16" x 1-1/4" hex head machine screw, lock washer, and hex nut. Note that the *Bracket* goes on the underside of the *Handle*.

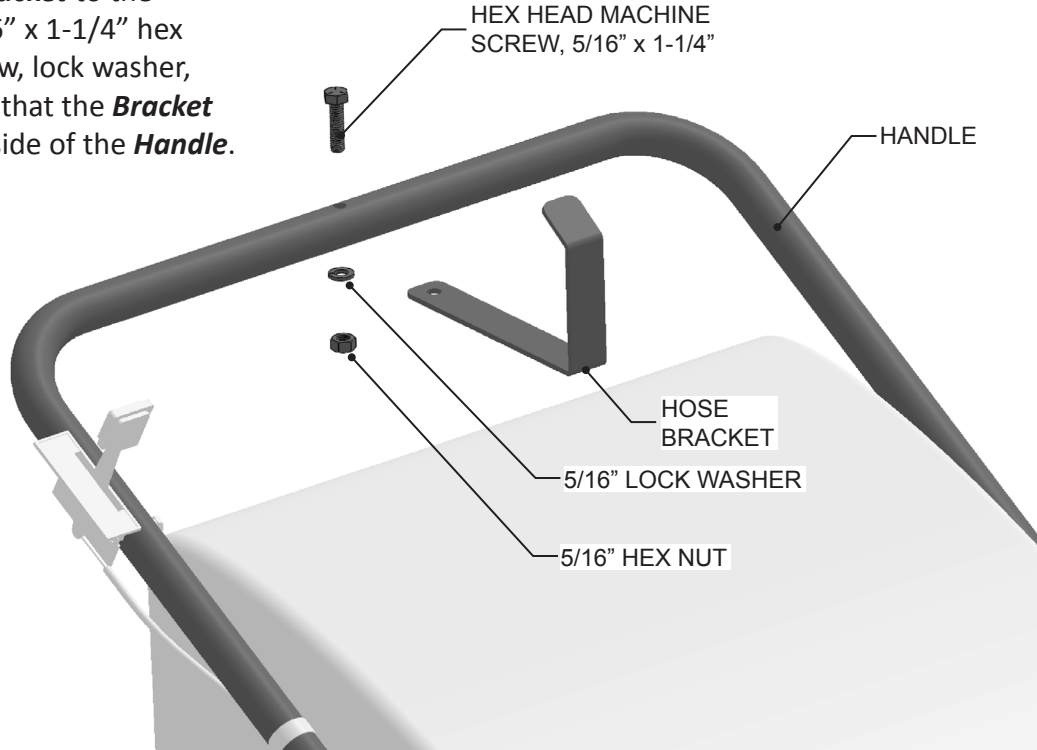

HEX HEAD MACHINE SCREW, 5/16" x 1-1/4"

HANDLE

HOSE BRACKET

5/16" LOCK WASHER

5/16" HEX NUT

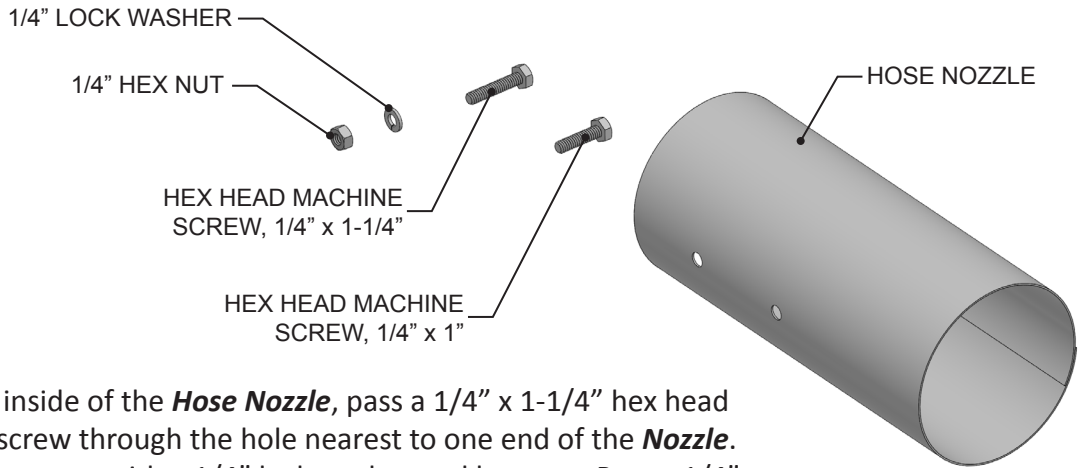

- 3.** From the inside of the **Hose Nozzle**, pass a 1/4" x 1-1/4" hex head machine screw through the hole nearest to one end of the **Nozzle**. Secure the screw with a 1/4" lock washer and hex nut. Pass a 1/4" x 1" hex head machine screw through the other hole.

- 4.** Position the **Hose Handle** onto the two screws installed in Step 3 and secure with 1/4" lock washers and hex nuts. Some minor distortion of the **Hose Nozzle** may occur as the fasteners are tightened. This is normal.

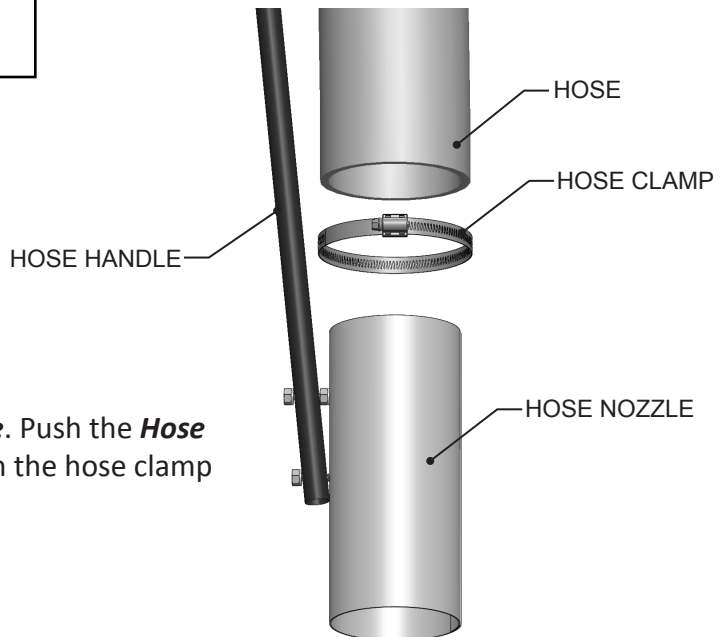
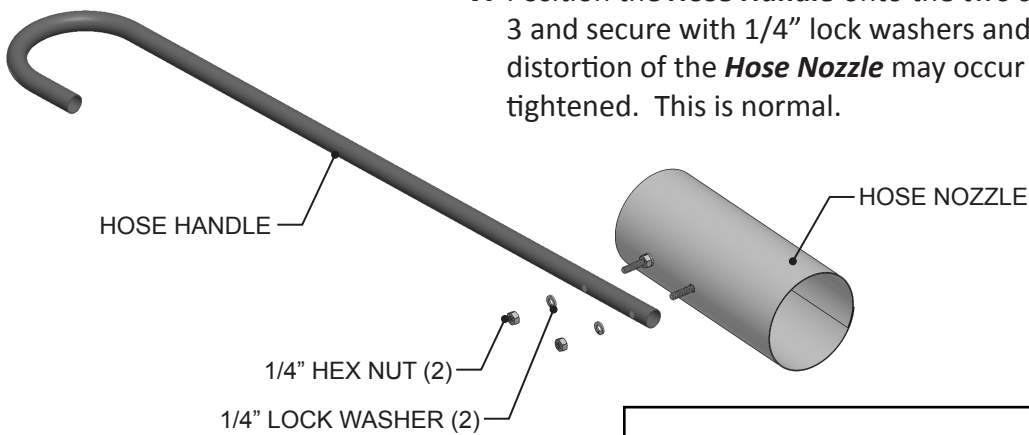

- 5.** Slide a hose clamp onto the **Hose**. Push the **Hose** onto the **Hose Nozzle** and tighten the hose clamp to secure it.

- 6.** Insert the **Hose Nozzle** into the **Hose Cup**. Route the **Hose** over the machine as shown. Trim the **Hose** to length so that it doesn't drag on the ground or interfere with the machine's wheels. Slide a hose clamp over the free end of the **Hose**. Push the free end of the **Hose** onto the port on the machine's **Inlet Housing** and tighten the hose clamp to secure it.



# USING THE OPTIONAL HOSE

Your Power-Vac's **Hose** (if so equipped) can be used with or without a **Hose Baffle**, depending on the type of litter or debris to be vacuumed. The **Hose** will have adequate suction for most materials without any baffling. When maximum suction is needed for heavy or difficult-to-pickup waste, however, Elgee's Hose Baffles should be used. These divert all of the Power-Vac's suction to the hose by blocking off the debris inlet within the **Inlet Housing**. A **Manual Hose Baffle** is included with all Hose kits unless the optional **Onboard Hose Baffle** is purchased. To use the **Hose**:

1. Start the engine and set the **Throttle Control** to "Idle".
- 2a. **NO BAFFLE:** Skip to Step 3 to use the **Hose** without any baffling.
- 2b. **MANUAL HOSE BAFFLE:** Slide the **Manual Hose Baffle** under the machine to the position shown below. This will prevent interference between the **Front Caster** and the **Manual Hose Baffle's** handle. When properly positioned, the **Manual Hose Baffle's** disc will contact the rear of the machine's **Inlet Housing**. Skip to Step 3.

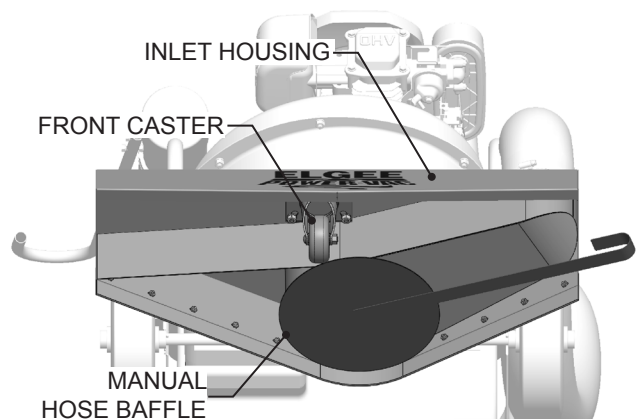

- 2c. **ONBOARD HOSE BAFFLE:** If your machine is equipped with the optional **Onboard Hose Baffle**, simply press down on the **Baffle Control Handle** to release the locking pin and rotate it clockwise as far as it will go. Note: Pull the machine backwards a few inches before turning the **Baffle Control Handle** in order to ensure there will be no interference with the **Front Caster**.

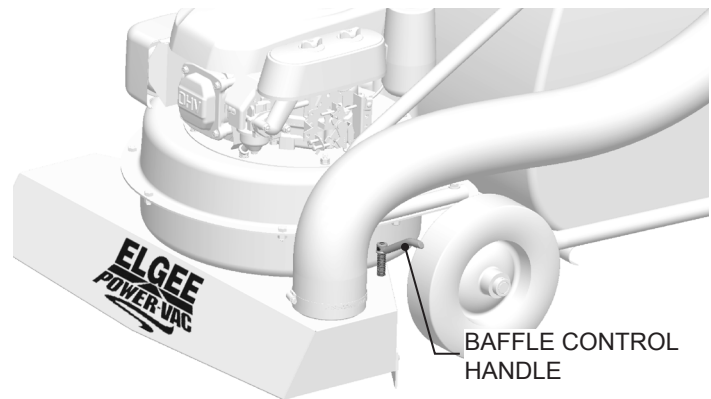

3. Set the **Throttle Control** to "Run".
4. Grasp the **Hose Handle**; withdraw the **Hose** and the **Hose Nozzle** from the **Hose Cup**.
5. Pick up debris.
6. Reverse the above procedures to return to wide area vacuuming.

# MAINTAINING YOUR POWER-VAC

Your Elgee Power-Vac has been designed to provide years of trouble-free service! Periodic attention to the engine and the Filter Bag is all that's needed to ensure that it always performs as well as when it was new.

**Engine** - Periodic oil changes as well as replacement of filters and similar items are necessary. Refer to the engine manufacturer's literature for specific requirements.

**Filter Bag** - Elgee Filter Bags hold the debris picked up by your Power-Vac and are designed to capture dust from the discharge air. To ensure that your machine continues to operate at peak efficiency:

- Shake the dust from the bag after each use to maintain maximum suction. Do this several times during the day if you're picking up mostly fine materials. Accumulated dust clogs the bag's pores, thereby reducing air flow and suction.
- For outdoor use where dust control is not an issue, opening the bag's vent zipper will extend the maximum suction time.
- Allow the bag to air dry if it becomes wet. A wet bag can rot or allow the growth of mold and mildew.
- Launder the bag only if necessary. Use cold water and hang the bag to air dry.

# ADDITIONAL RESOURCES AND CONTACT INFORMATION

**WEB:** [www.elgee.com](http://www.elgee.com)

Our website is full of helpful information and how-to videos.

Also visit our YouTube channel: [www.youtube.com/user/ElgeePowerVac](http://www.youtube.com/user/ElgeePowerVac)



**EMAIL:** [sales@elgee.com](mailto:sales@elgee.com)

We respond promptly to all email inquiries.

**PHONE:** 908-647-4100 or 800-742-0400

Call during normal business hours (8:30 am - 4:30 pm EST Monday through Friday) to speak with a knowledgeable representative.

**FAX:** 908-647-4242

**MAIL AND SHIPPING:** Elgee Manufacturing Co., Inc.  
225 Stirling Road  
Warren, NJ 07059

# ELGEE POWER-VAC LIMITED WARRANTY

For ONE YEAR from date of installation for the original purchases, Elgee will repair or replace (at Elgee's option), FREE OF CHARGE, any parts or parts found upon examination by the factory in Warren, New Jersey, or by any factory authorized center, to be defective in material and/or workmanship.

Except for bags, wiring, fuel tubes, cables, brass nipples, and rubber parts, Elgee parts carry a ONE YEAR warranty against mechanical defects and workmanship. Should defects become evident, parts must be returned, prepaid, to our factory for inspection. Elgee will not be responsible for repairs made outside of the factory without authorization.

Charges for removal, reconnection, shipping and/or transportation of parts submitted for replacement under this warranty must be borne by the purchaser.

Any changes or modification of this unit without the expressed written consent of Elgee Manufacturing Co., Inc. will void this warranty.

Anything related to the conversion of an engine to propane fuel burning voids the manufacturer's warranty pertaining to any part directly associated with propane fuel combustion. All other engine components carry full manufacturer's warranty.

Engine warranty is carried by the manufacturer and their authorized dealers. Honda engines carry a TWO YEAR warranty. Briggs & Stratton offers a ONE YEAR warranty on their Industrial/Commercial (I/C) engines and their 6HP Intek engines. Their warranty for standard engines is 90 DAYS.

No warranty is expressed or implied. Elgee and any or all of its subcontractors shall in any event NOT be liable for consequential damages.

Implied warranties, including those of merchantability and fitness for a particular purpose, are limited to ONE YEAR from the date of purchase and to the extent permitted by law. Any and all implied warranties are excluded. This is the exclusive remedy and liability for consequential damages under any and all warranties. Warranties are excluded to the extent exclusion is permitted by law.