

ELGEE POWER-VAC



OWNER'S MANUAL

Congratulations on your purchase of an Elgee Power-Vac!

Your new machine is the perfect solution for debris and litter control at factories, warehouses, stables, sports arenas, amusement parks, and countless other facilities. The Power-Vac's ability to clean up to 40,000 square feet per hour will save you time and money!

CONTENTS

Assembling the Power-Vac	2
Handle Assembly	4
Propane Tank Mounting Frame Installation	6
Dolly Installation	8
Deflector Installation	9
Filter Bag Installation	10
Propane Tank Installation	11
Hose Assembly and Installation	13
Using the Optional Hose	17
Engine and Fuel System Operation	18
Maintaining your Power-Vac	20
Additional Resources and Contact Information	21
Elgee Power-Vac Limited Warranty	22

This Manual is applicable to all propane-fueled Power-Vac models:

632-LP, 632-LPH, 633-LP, 633-LPH, 634-LP, 634-LPH, 642-LP, 642-LPH, 643-LP, 643-LPH, 644-LP, 644-LPH **(Model 642-LPH shown on cover)**

ASSEMBLING THE POWER-VAC

Assembling your new *Elgee Power-Vac* is a snap. Just follow the instructions on the next few pages and you'll be up and running in no time!

Below is an exploded view showing the main components to be assembled. The hardware that is used is detailed on the next page.

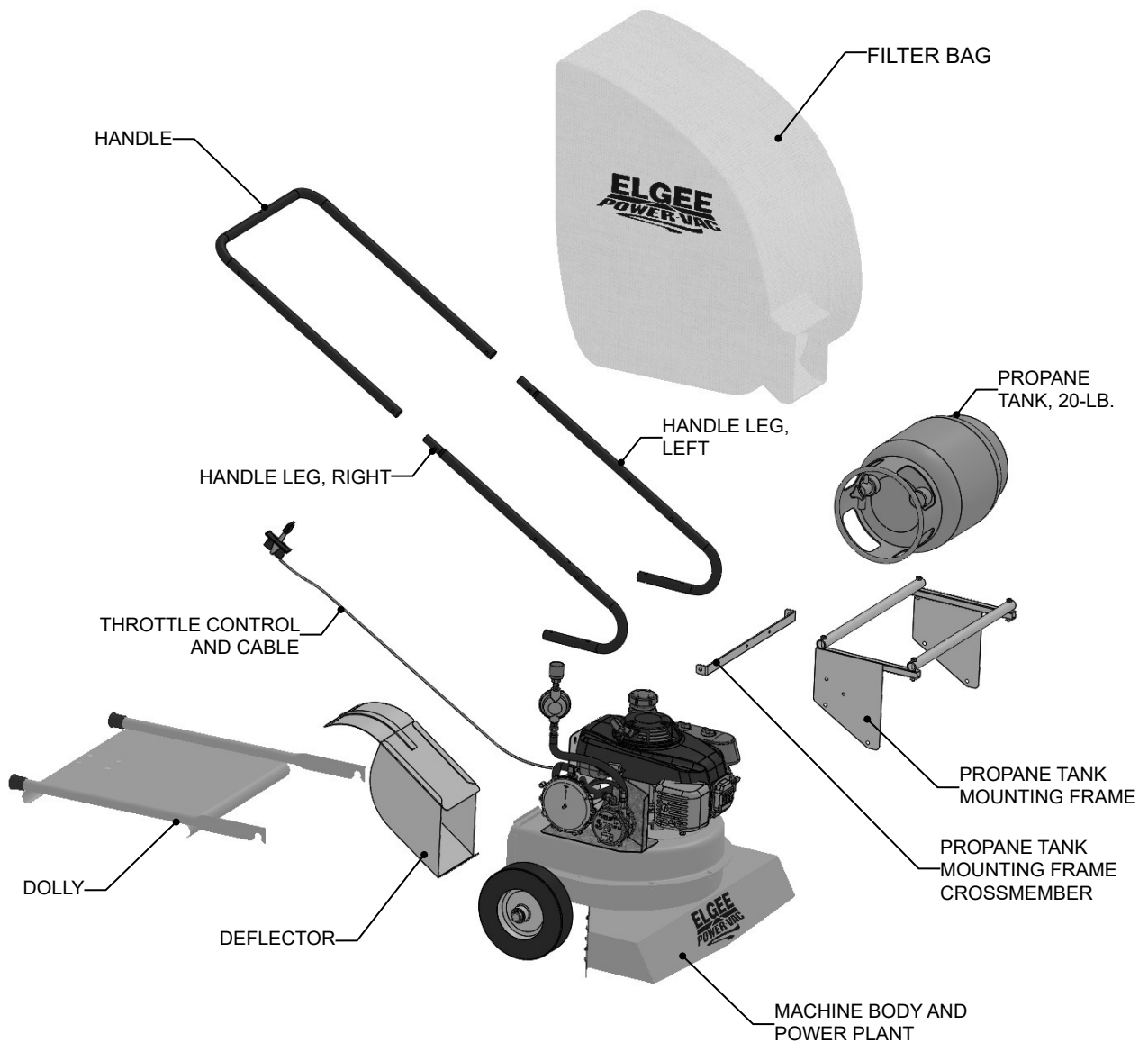

You'll need just a few tools . . .

- Ratchet wrench with 1/2" socket, 7/16" socket, and extension
- 1/2" Open end wrench
- 7/16" Open end wrench
- 3/8" Open end wrench
- #2 Phillips screwdriver
- Rubber mallet

All the hardware you'll need is provided . . .

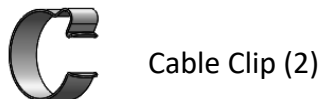
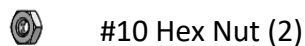
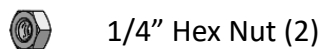
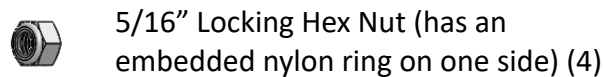
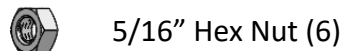
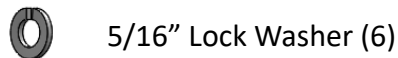
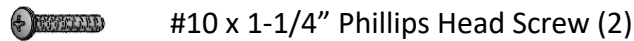
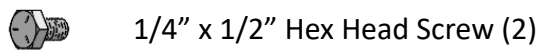
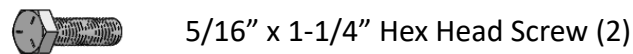
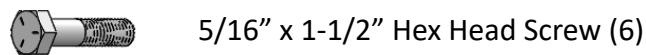
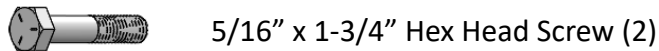

HANDLE ASSEMBLY

1. Attach the **Left and Right Handle Legs** to the machine body. NOTE: The **Right Handle Leg** has five holes and goes on the right side of the machine (when viewed from the operator's position); the **Left Handle Leg** has only three holes and goes on the left side. For each leg, use two hex-head machine screws, flat washers, and locking hex nuts as shown in the illustrations below.

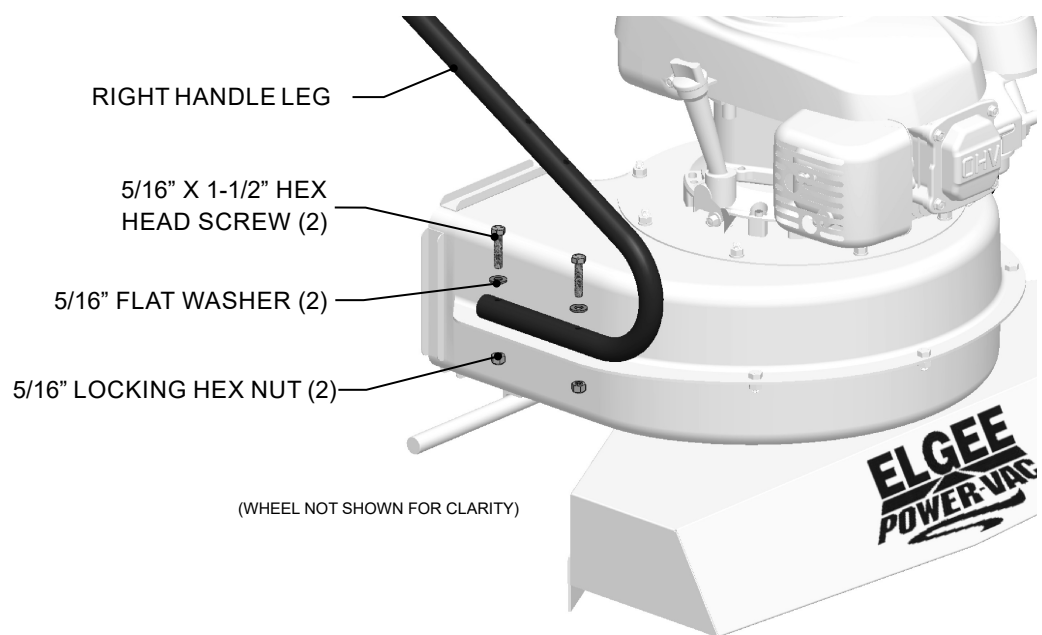
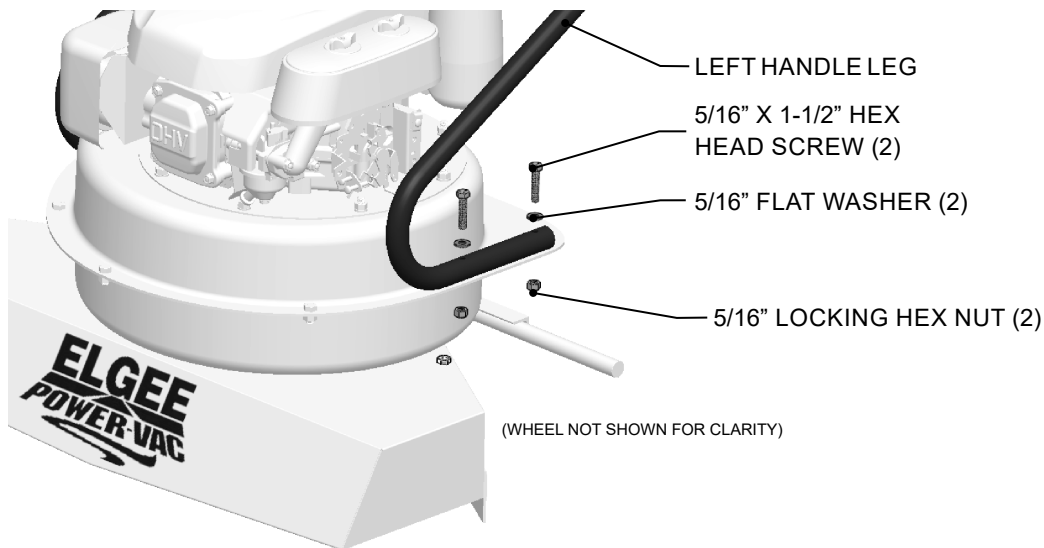

- 2.** Slide the **Handle** onto the **Right and Left Handle Legs** and attach with two hex-head machine screws, flat washers, and hex nuts as shown in the illustration. The two holes nearest the bend must be on the right side of the machine when viewed from the operator's position.

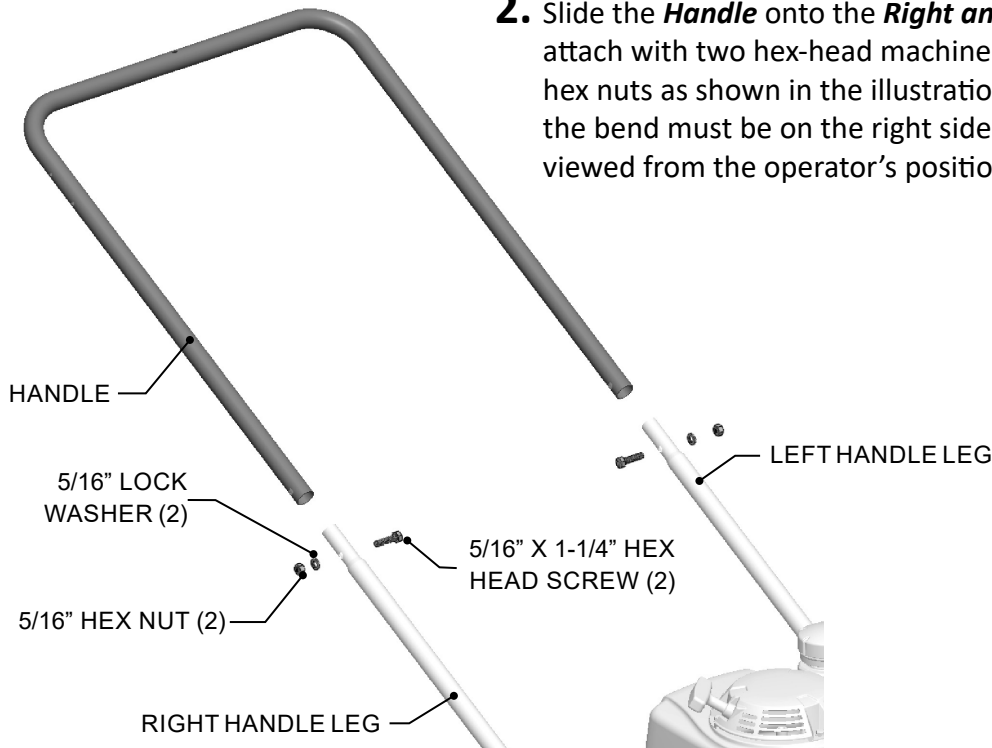

- 3.** Attach the **Throttle Control** to the **Handle** with Phillips head screws, lock washers, and nuts. Use the two holes in the **Handle** closest to the bend.

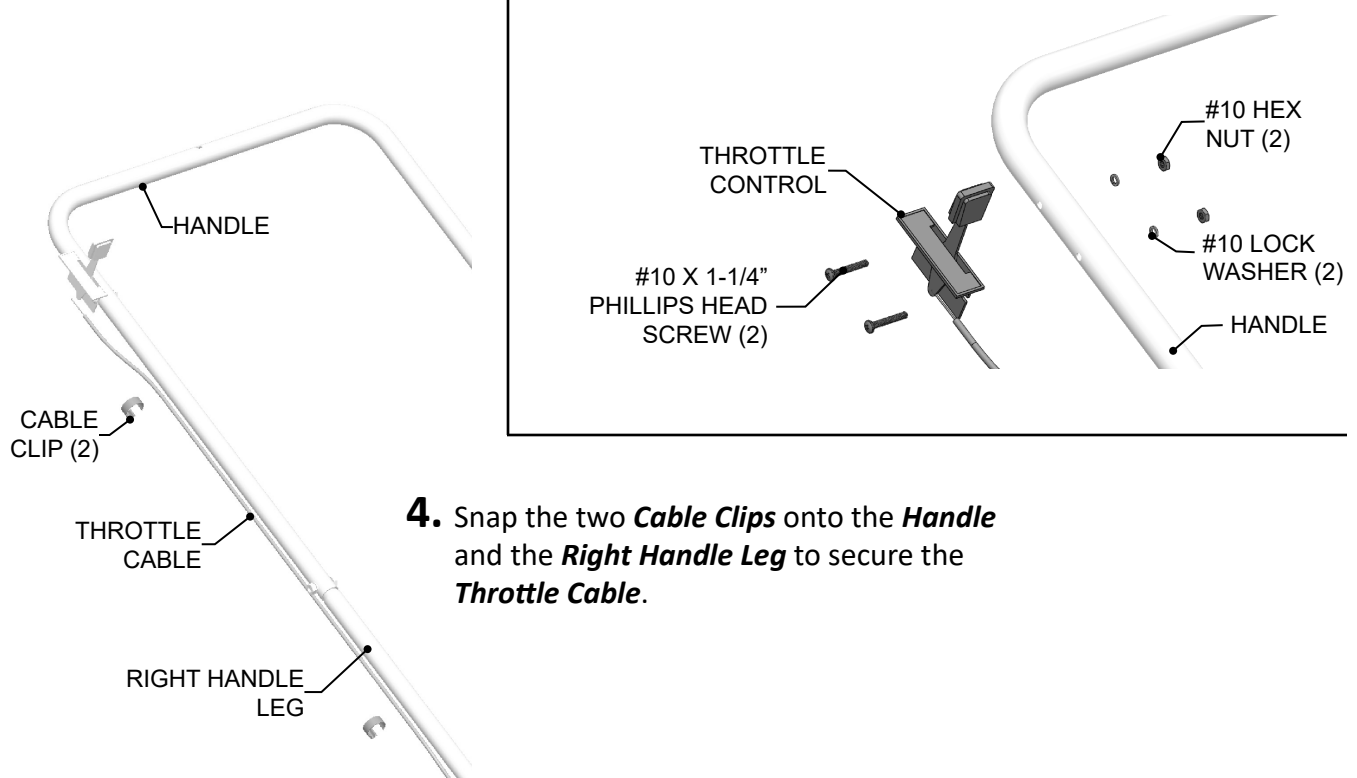

- 4.** Snap the two **Cable Clips** onto the **Handle** and the **Right Handle Leg** to secure the **Throttle Cable**.

PROPANE TANK MOUNTING FRAME INSTALLATION

1. Position the **Propane Tank Mounting Frame** so that its Side Panels are on the outside of the **Handle Legs**. Fasten the **Frame** in place through the Side Panel holes closest to the front of the machine using two hex head machine screws (one per side), lock washers, and hex nuts. Leave the fasteners somewhat loose until later.

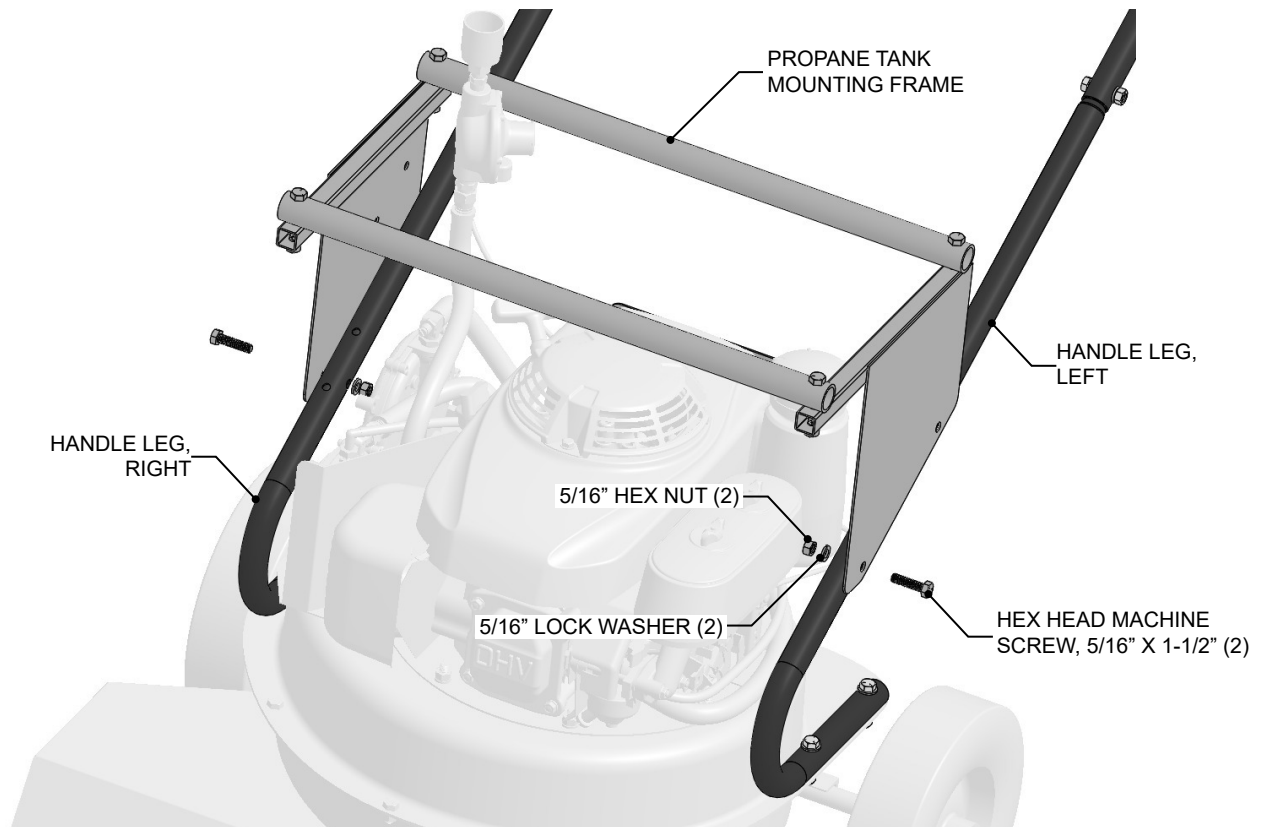

2. Loosely attach the **Crossmember** to the **Crossmember Bracket** using two hex head machine screws, lock washers, and hex nuts.

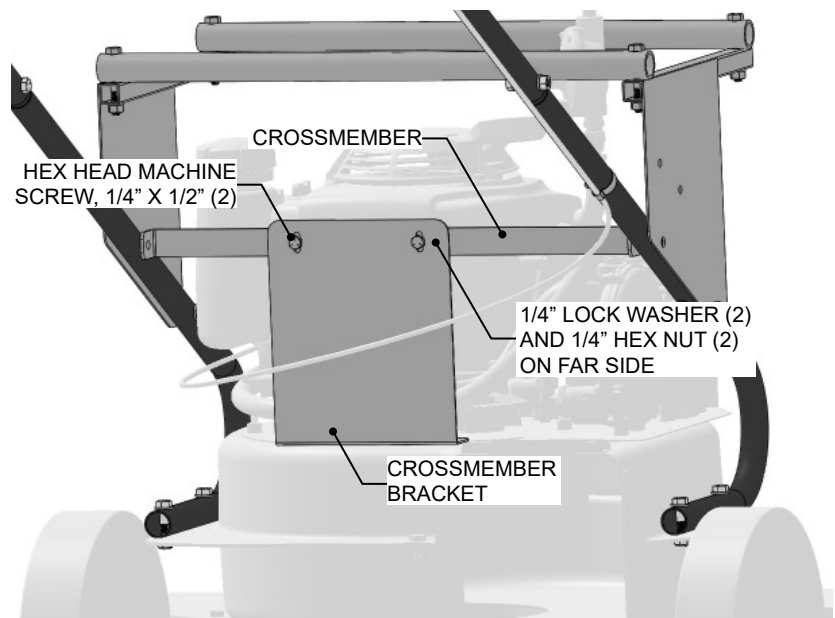

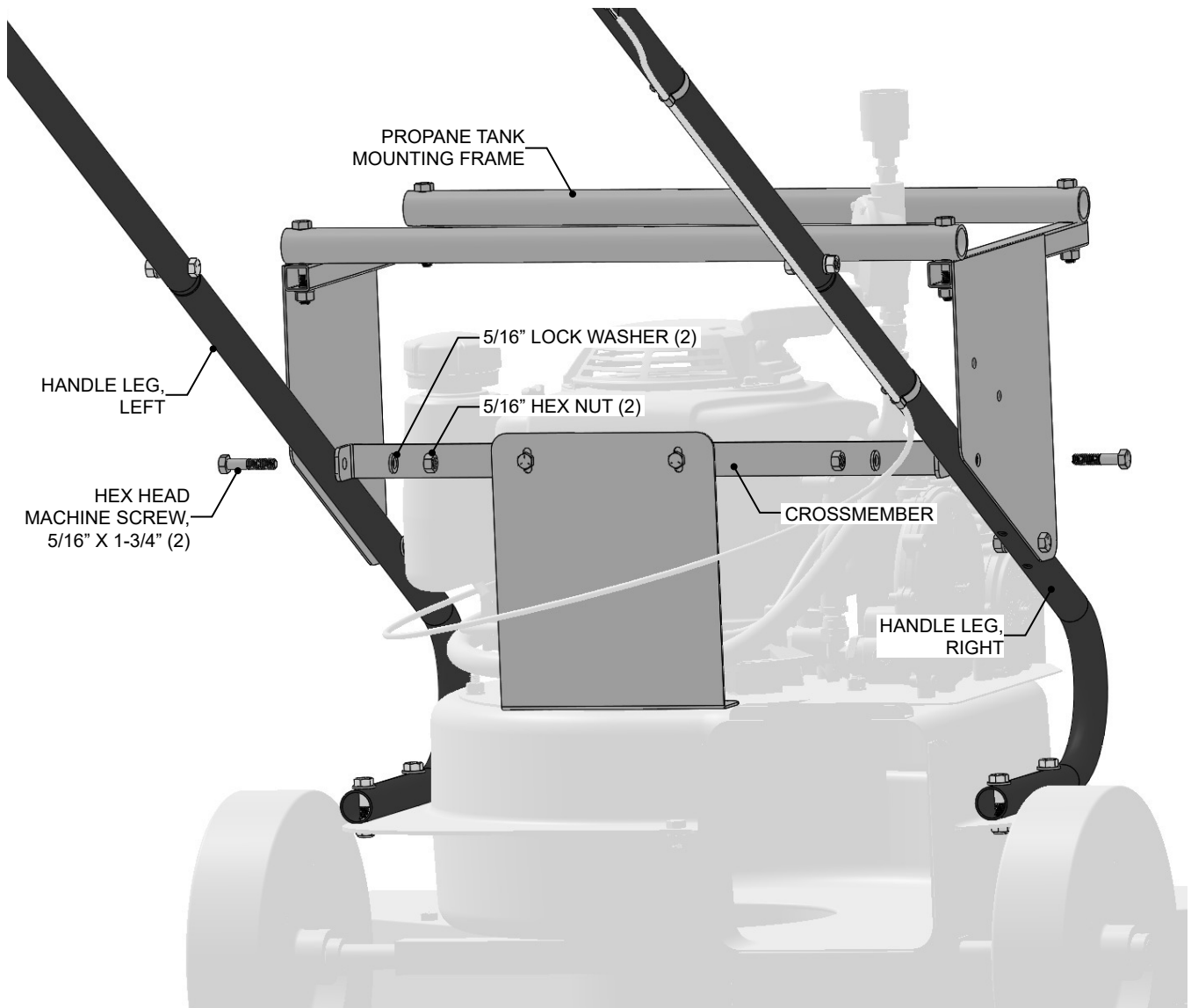

3. With two hex head machine screws (one per side), lock washers, and hex nuts, attach the **Crossmember** to the **Propane Tank Mount** and the **Handle Legs**.

4. Fully tighten all of fasteners installed in Steps 1 through 3.

DOLLY INSTALLATION

1. Line up the half hole of the *Dolly* with the machine's *Axle*.
2. Strike the *Dolly* above the hole with a rubber mallet to snap it into place.

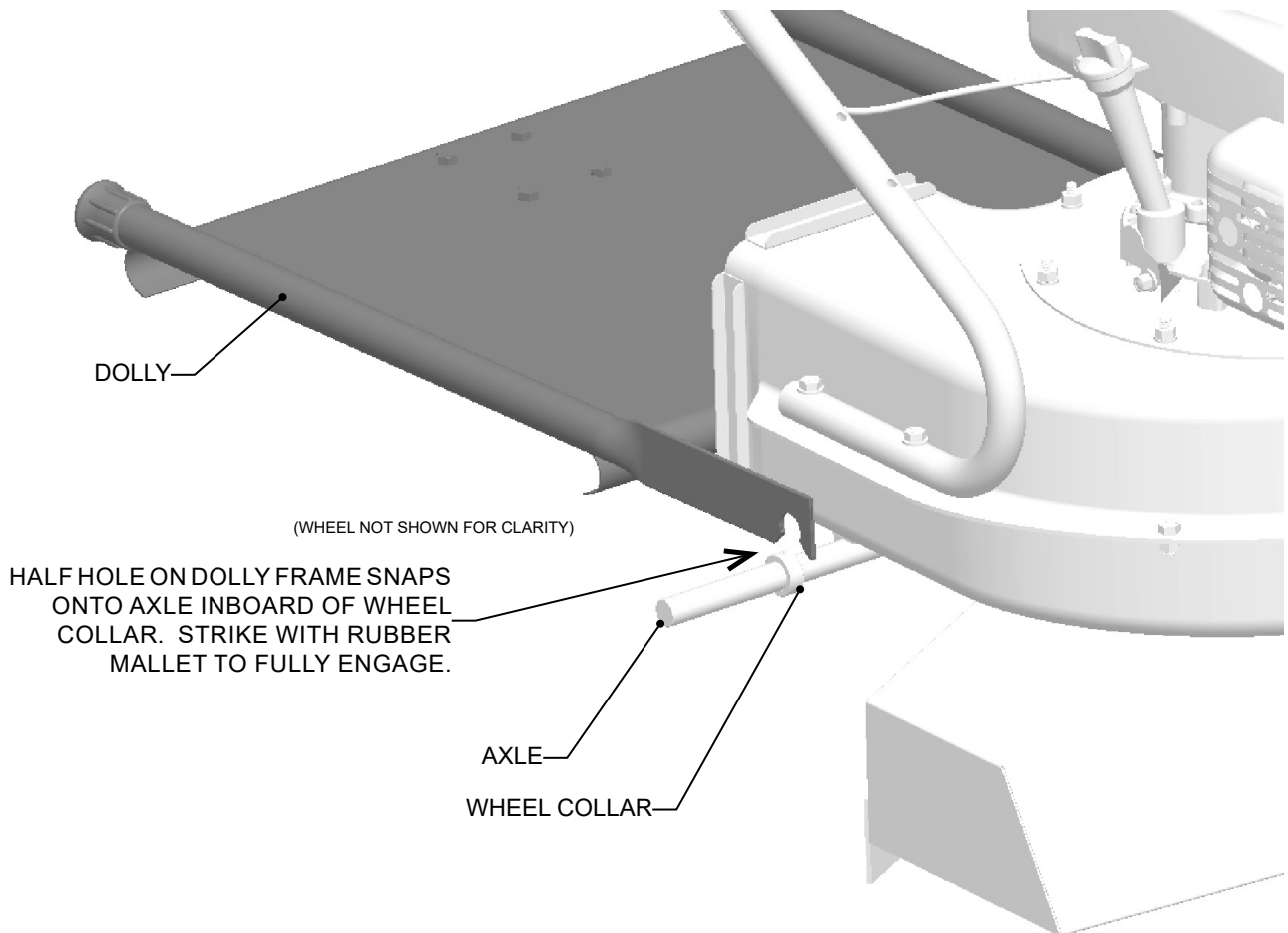

DEFLECTOR INSTALLATION

1. Position the **Deflector** towards the inside of the machine so that its top and bottom lips will engage the channels on the discharge chute.
2. Use a rubber mallet to force the **Deflector** outward until it is centered on the discharge chute.

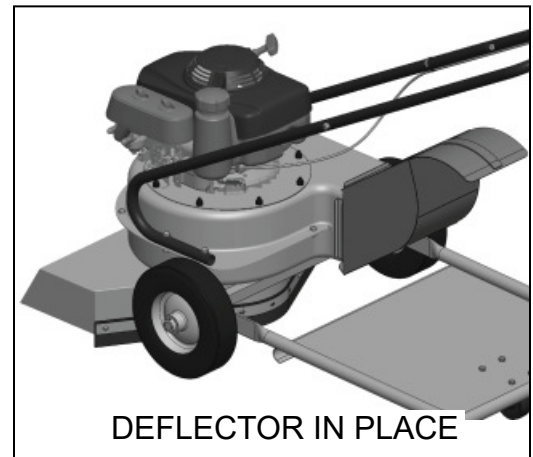
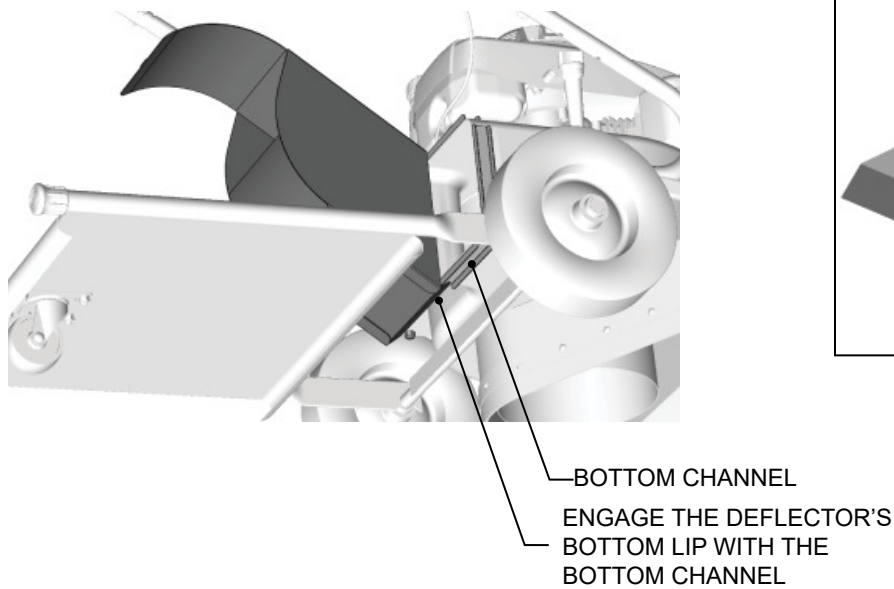
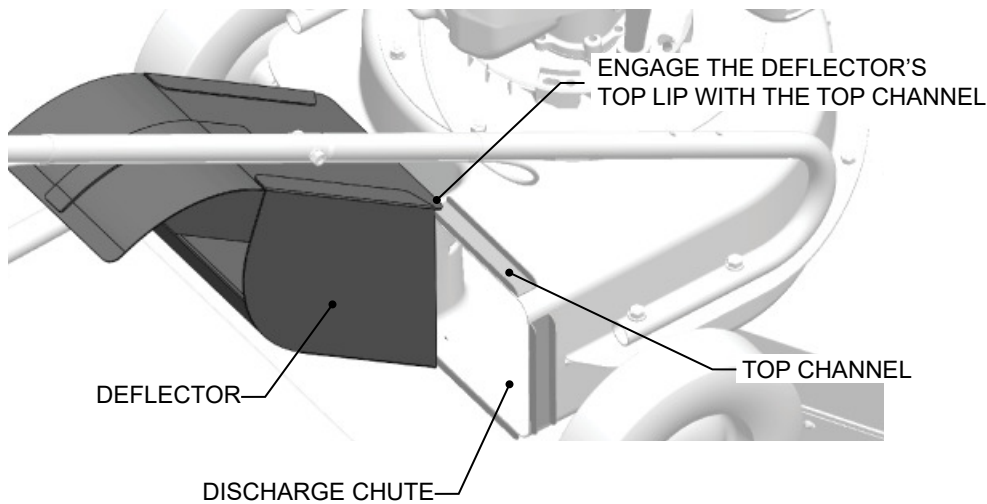

NEVER OPERATE THE MACHINE WITHOUT THE DEFLECTOR IN PLACE.

FILTER BAG INSTALLATION

1. Place the neck of the **Filter Bag** over the **Deflector** so that it covers the channels on the machine's discharge outlet.



2. Cinch the **Filter Bag's** built-in strap to secure its neck.



3. Loop each pair of the **Filter Bag's** handle straps around the **Handle** and fasten the metal clasps to join them.



**NEVER OPERATE THE MACHINE WITHOUT THE FILTER BAG IN PLACE.
EMPTY THE FILTER BAG IMMEDIATELY AFTER EACH USE.**

PROPANE TANK INSTALLATION



THE PROPANE TANK USED ON YOUR ELGEE POWER-VAC MUST BE:

- Designed and plumbed for VAPOR (not liquid) service;
- Designed for horizontal use;
- Of 20-lb. (5-gallon) capacity;
- Equipped with a Relief Valve and an Overfill Prevention Device (OPD);
- UL and/or DOT rated.

Purchasing your propane tank from Elgee ensures that these requirements will be met!

Use of a non-compliant tank voids Elgee's warranty.



- 1.** Place the **Propane Tank** onto the **Propane Tank Mounting Frame** in the orientation shown. The Relief Valve on the **Tank** should be at the top.

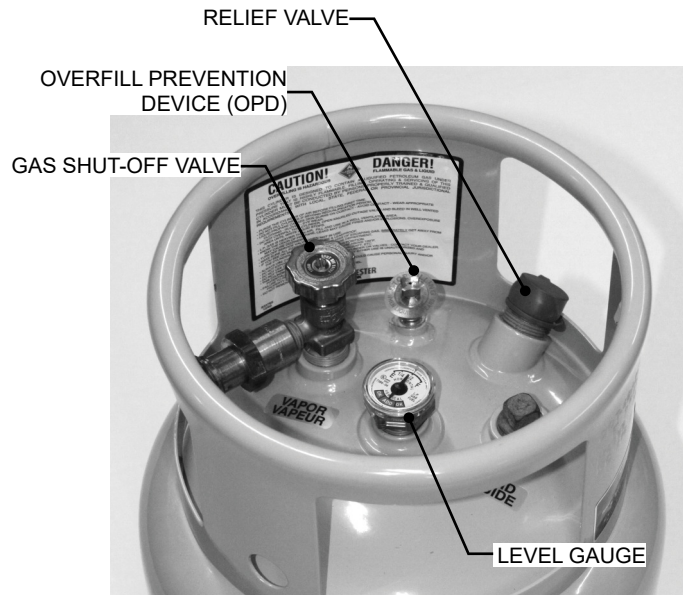



2. Loop the two nylon straps over the ends of the **Propane Tank** and cinch them tight to secure the **Tank** to the **Frame**.

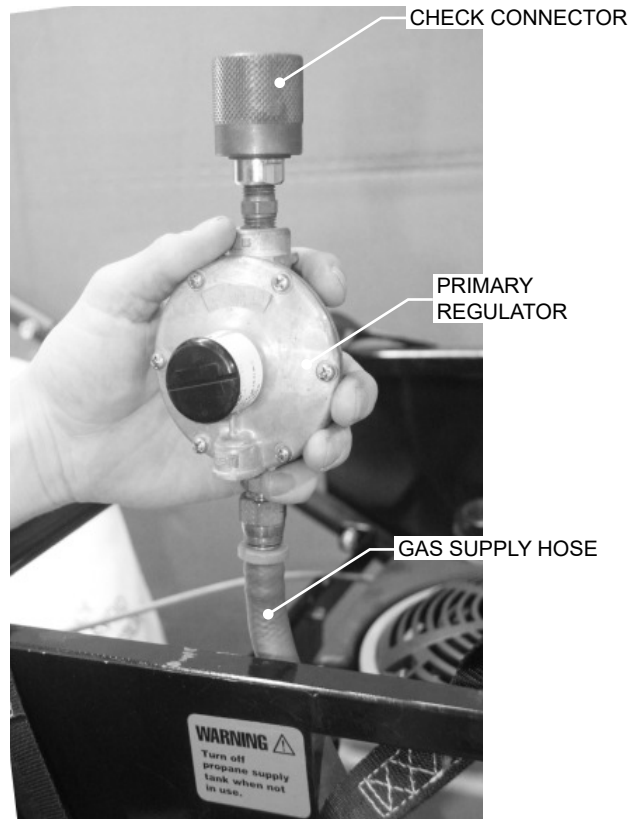
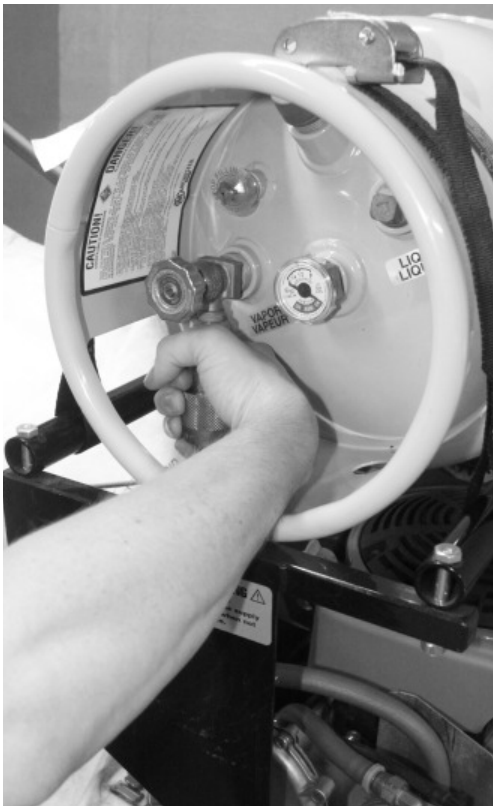

3. Locate the **Gas Supply Hose** to which is attached to the **Primary Regulator** and the **Check Connector**.

4. Thread the sleeve of the **Check Connector** on to the **Propane Tank's** Gas Shut-Off Valve. Hand-tighten only by gripping the knurled sleeve.

HOSE ASSEMBLY AND INSTALLATION (OPTIONAL)

The next few pages describe the assembly, installation, and use of the optional *Power-Vac Hose*. **Skip ahead to page 2018 if you have not purchased this accessory.** Below is an exploded view showing the parts included with the kit.

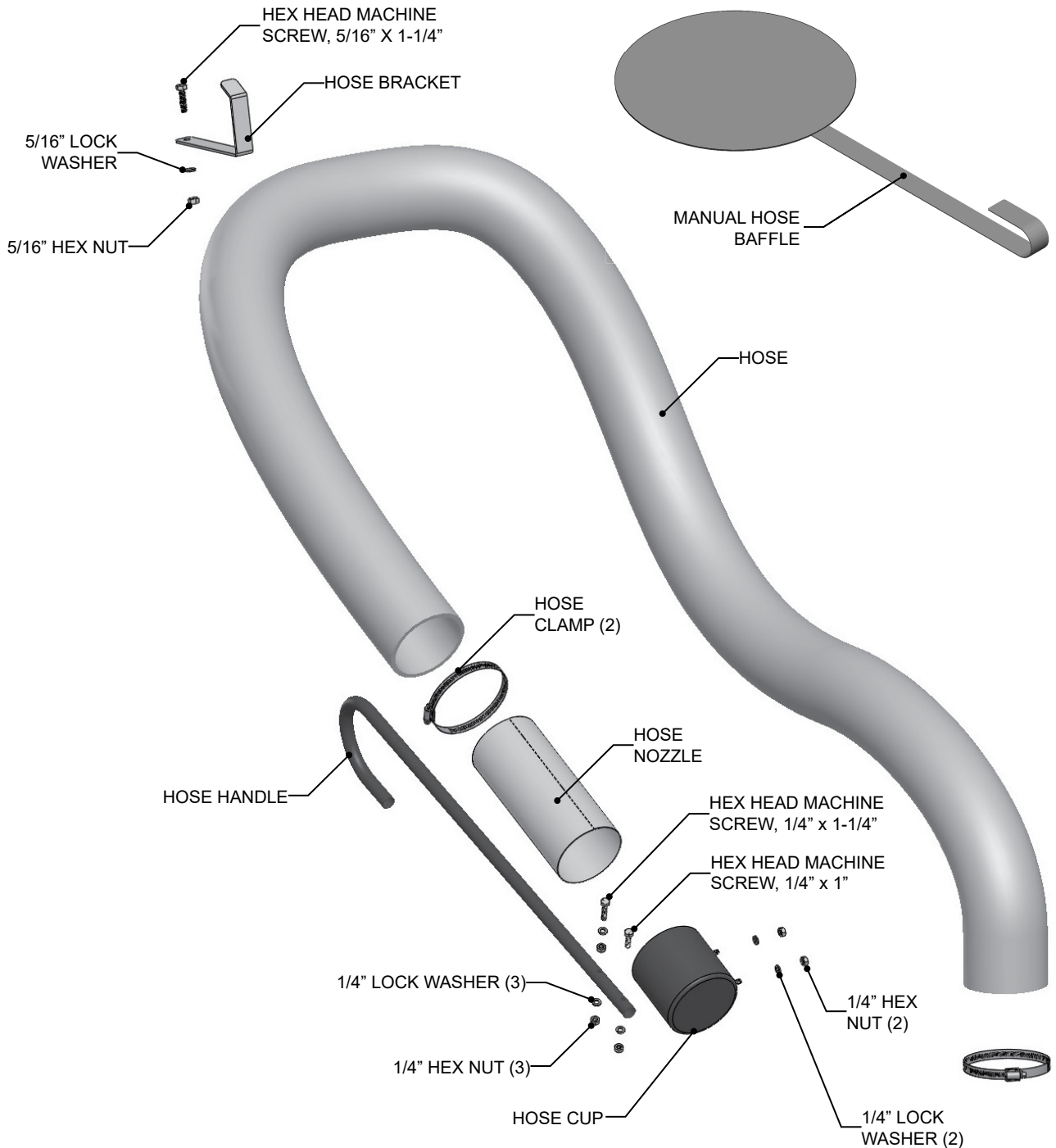

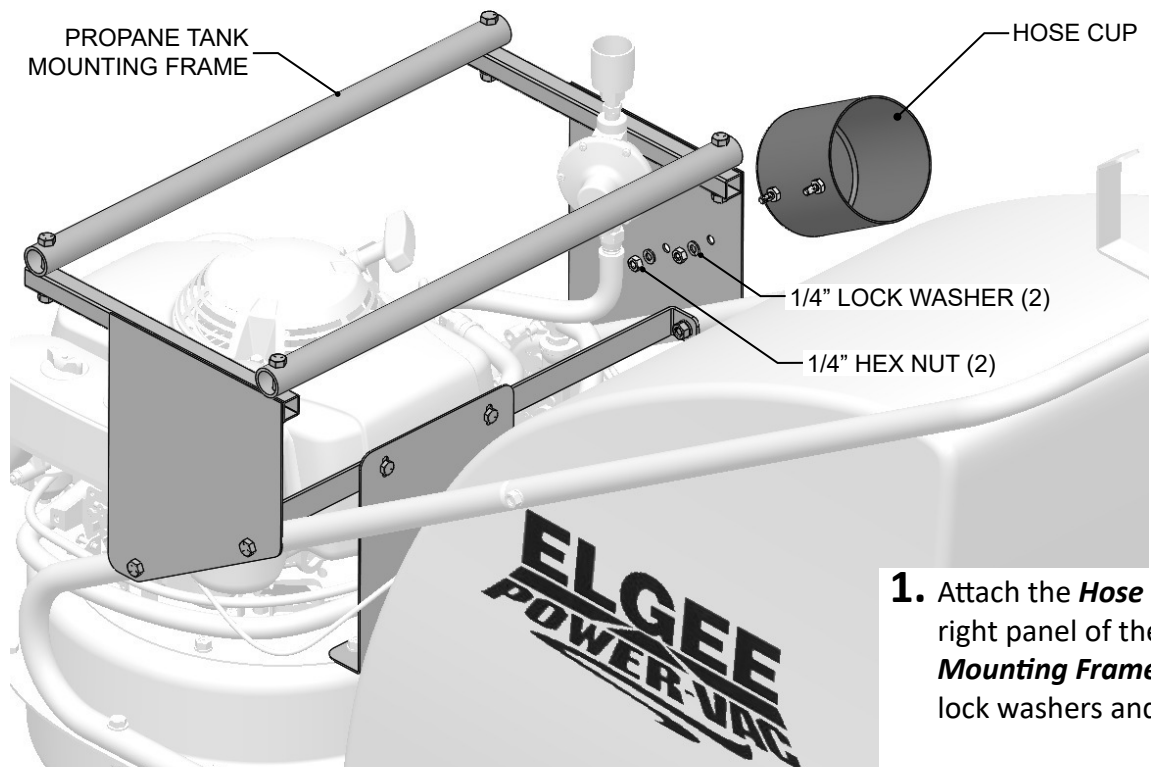

1. Attach the *Hose Cup* to the right panel of the *Propane Tank Mounting Frame* with two 1/4" lock washers and hex nuts.

2. Attach the *Hose Bracket* to the *Handle* with a 5/16" x 1-1/4" hex head machine screw, lock washer, and hex nut. Note that the *Bracket* goes on the underside of the *Handle*.

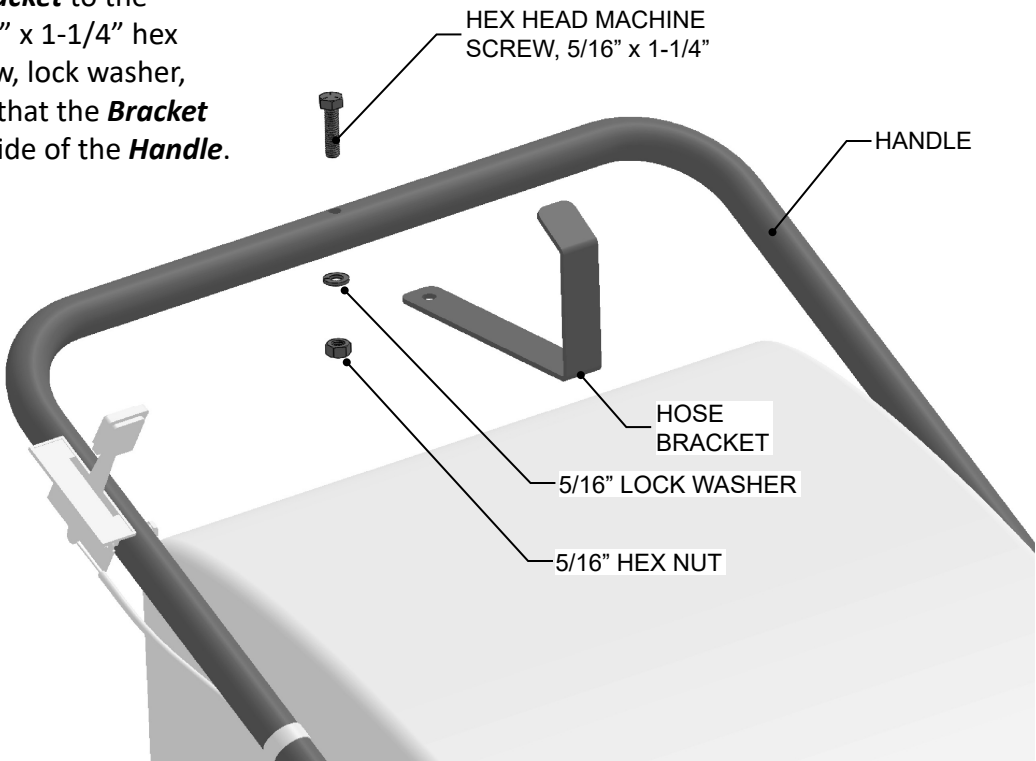

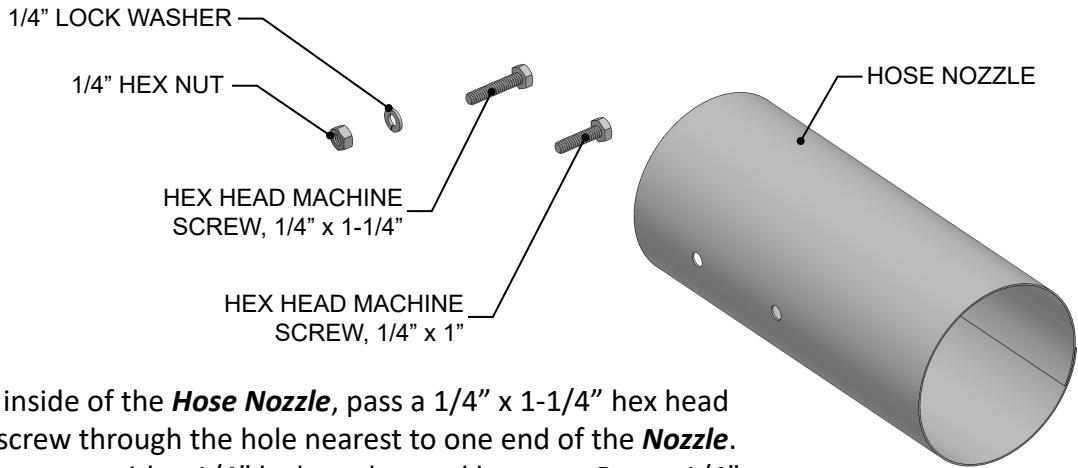

- 3.** From the inside of the **Hose Nozzle**, pass a 1/4" x 1-1/4" hex head machine screw through the hole nearest to one end of the **Nozzle**. Secure the screw with a 1/4" lock washer and hex nut. Pass a 1/4" x 1" hex head machine screw through the other hole.

- 4.** Position the **Hose Handle** onto the two screws installed in Step 3 and secure with 1/4" lock washers and hex nuts. Some minor distortion of the **Hose Nozzle** may occur as the fasteners are tightened. This is normal.

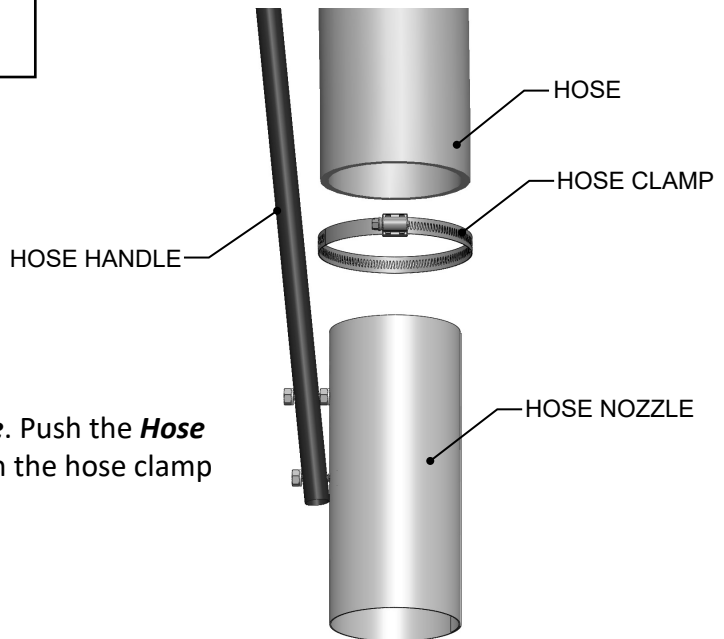
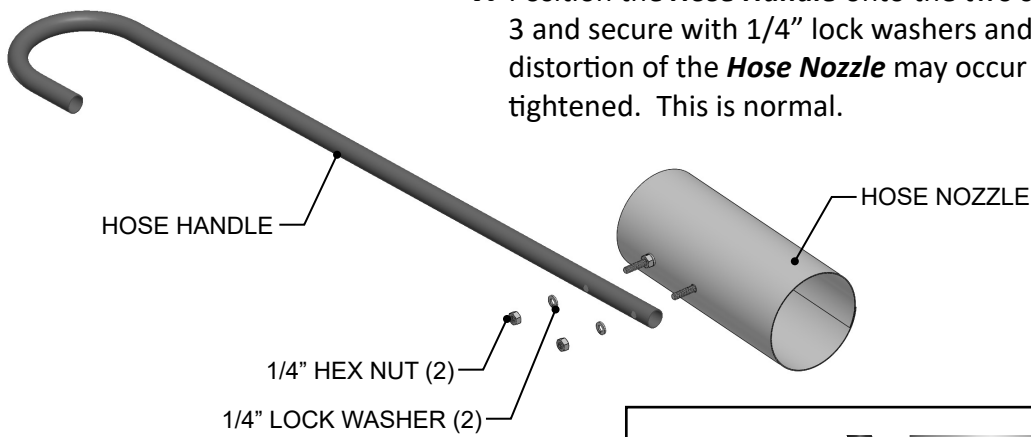

- 5.** Slide a hose clamp onto the **Hose**. Push the **Hose** onto the **Hose Nozzle** and tighten the hose clamp to secure it.

6. Insert the **Hose Nozzle** into the **Hose Cup**. Route the **Hose** over the machine as shown. Trim the **Hose** to length so that it doesn't drag on the ground or interfere with the machine's wheels. Slide a hose clamp over the free end of the **Hose**. Push the free end of the **Hose** onto the port on the machine's **Inlet Housing** and tighten the hose clamp to secure it.



USING THE OPTIONAL HOSE

Your Power-Vac's **Hose** (if so equipped) can be used with or without a **Hose Baffle**, depending on the type of litter or debris to be vacuumed. The **Hose** will have adequate suction for most materials without any baffling. When maximum suction is needed for heavy or difficult-to-pickup waste, however, Elgee's Hose Baffles should be used. These divert all of the Power-Vac's suction to the hose by blocking off the debris inlet within the **Inlet Housing**. A **Manual Hose Baffle** is included with all Hose kits unless the optional **Onboard Hose Baffle** is purchased. To use the **Hose**:

1. Start the engine and set the **Throttle Control** to "Idle".
- 2a. **NO BAFFLE:** Skip to Step 3 to use the **Hose** without any baffling.
- 2b. **MANUAL HOSE BAFFLE:** Slide the **Manual Hose Baffle** under the machine to the position shown below. This will prevent interference between the **Front Caster** and the **Manual Hose Baffle's** handle. When properly positioned, the **Manual Hose Baffle's** disc will contact the rear of the machine's **Inlet Housing**. Skip to Step 3.

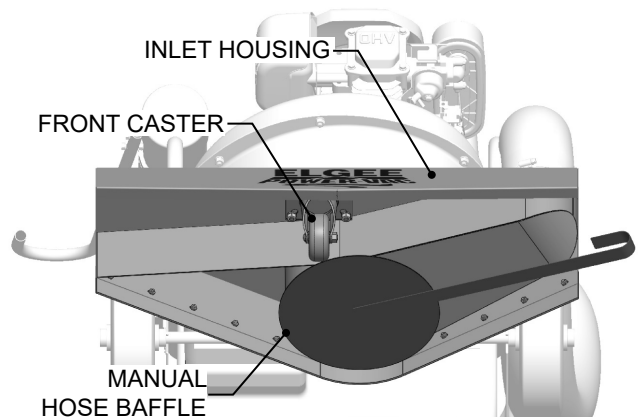

- 2c. **ONBOARD HOSE BAFFLE:** If your machine is equipped with the optional **Onboard Hose Baffle**, simply press down on the **Baffle Control Handle** to release the locking pin and rotate it clockwise as far as it will go. Note: Pull the machine backwards a few inches before turning the **Baffle Control Handle** in order to ensure there will be no interference with the **Front Caster**.

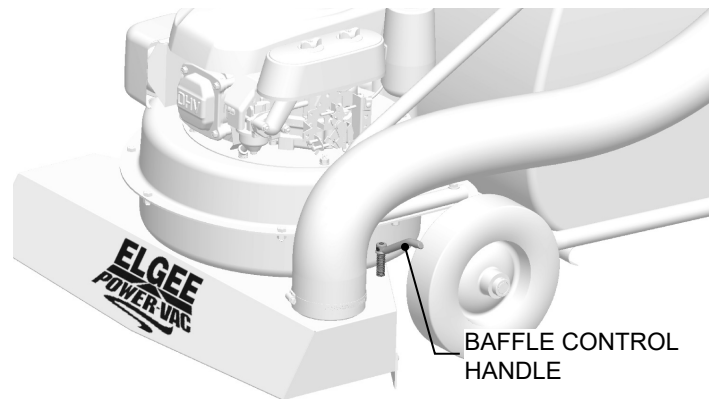

3. Set the **Throttle Control** to "Run".
4. Grasp the **Hose Handle**; withdraw the **Hose** and the **Hose Nozzle** from the **Hose Cup**.
5. Pick up debris.
6. Reverse the above procedures to return to wide area vacuuming.

ENGINE AND FUEL SYSTEM OPERATION

STARTING THE ENGINE

1. Open the Gas Shut-Off Valve on the **Propane Tank** by turning its knob all the way counterclockwise. Photo right.
2. For Honda engines, open the throttle halfway. For Briggs & Stratton engines, set the throttle control to the idle position.
3. Near the front on the right side of the machine, locate the **Secondary Regulator** and the **Vacuum Fuel Lock**. Photo below left.
4. Simultaneously depress the spring-loaded Primers on both the **Secondary Regulator** and the **Vacuum Fuel Lock** for several seconds. Photo below right.
5. Pull the starter cord. (Do this quickly before fuel vapor in the carburetor dissipates).



STOPPING THE ENGINE

1. Close the Gas Shut-Off Valve on the **Propane Tank** by turning its knob all the way clockwise. Photo top right.
2. Move the throttle control to "Stop".
3. Simultaneously depress both spring-loaded Primers for several seconds. Photo bottom right. NOTE: The engine may continue to run for a brief time until residual fuel vapor is consumed.

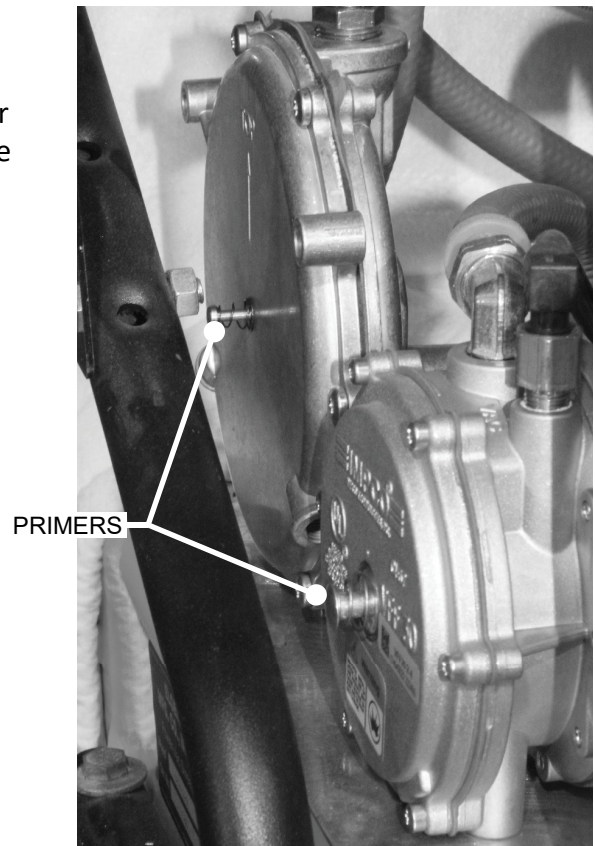
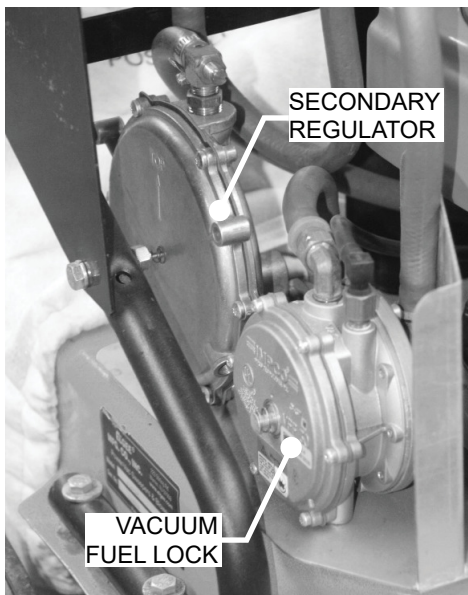

FUEL MIXTURE ADJUSTMENT

The engine on your Elgee Power-Vac has been calibrated at the factory for optimum performance at sea level. Various environmental factors, such as high altitude, may require adjustment of the fuel fixture. To do this:

1. Locate the Load Block at the top of the **Secondary Regulator** (see Page 18). Threaded into the Load Block is a Needle Valve with a Locking Nut.
2. Loosen the Locking Nut and turn the Needle Valve all the way in (clockwise).
3. Open the Needle Valve in half-turn steps while trying to start the engine.
4. Once the engine has started, continue opening the Needle Valve until the engine begins to idle roughly. Note the position of the Needle Valve at this point (over rich).
5. Now gradually close the Needle Valve. The engine should transition from a rough idle to smooth running and back to a rough idle. Note the position of the Needle Valve at this point (over lean).
6. Set the Needle Valve midway between the over rich and over lean positions. Tighten the Needle Valve's Locking Nut.

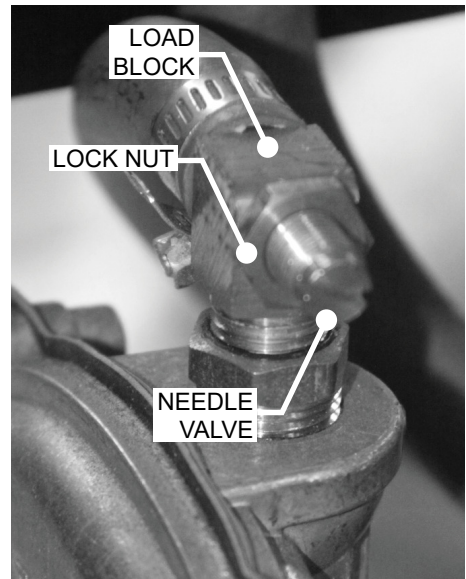

LEAK TESTING AND REPAIR

Do the following if you smell gas or suspect a gas leak:

1. Create a soapy solution of one part dish soap and three parts water.
2. Turn on the fuel supply.
3. Generously apply the soap solution with a paint brush or squirt bottle to fittings, connections, and hoses.
4. Bubbles appearing to 'grow' indicate a gas leak. Immediately shut off the gas supply.

Follow the procedure below to repair most gas leaks:

1. Make sure the gas supply has been shut off.
2. Simultaneously depress the spring-loaded Primers on both the **Secondary Regulator** and the **Vacuum Fuel Lock** for several seconds. See Page 18.
3. Rinse off the soapy solution and then dry the area.
4. Tighten loose joints, applying thread sealant where necessary. Replace defective fittings and hoses.
5. Repeat the leak test procedure to confirm that no leaks are present.



DANGER

NEVER smoke or allow any potential source of ignition (sparks, electrical arcing, etc.) in the area while performing a leak test. Fire or explosion may result.

NEVER conduct a leak test using fire or flame.



DANGER

ALWAYS be extremely careful when working around hot engine parts.



WARNING

NEVER attempt to repair leaks at any of the valves on the propane tank!

MAINTAINING YOUR POWER-VAC

Your Elgee Power-Vac has been designed to provide years of trouble-free service! Periodic attention to the engine and the Filter Bag is all that's needed to ensure that it always performs as well as when it was new.

Engine - Periodic oil changes as well as replacement of filters and similar items are necessary. Refer to the engine manufacturer's literature for specific requirements.

Filter Bag - Elgee Filter Bags hold the debris picked up by your Power-Vac and are designed to capture dust from the discharge air. To ensure that your machine continues to operate at peak efficiency:

- Shake the dust from the bag after each use to maintain maximum suction. Do this several times during the day if you're picking up mostly fine materials. Accumulated dust clogs the bag's pores, thereby reducing air flow and suction.
- For outdoor use where dust control is not an issue, opening the bag's vent zipper will extend the maximum suction time.
- Allow the bag to air dry if it becomes wet. A wet bag can rot or allow the growth of mold and mildew.
- Launder the bag only if necessary. Use cold water and hang the bag to air dry.

ADDITIONAL RESOURCES AND CONTACT INFORMATION

WEB: www.elgee.com

Our website is full of helpful information and how-to videos.

Also visit our YouTube channel: www.youtube.com/user/ElgeePowerVac



EMAIL: sales@elgee.com

We respond promptly to all email inquiries.

PHONE: 908-647-4100 or 800-742-0400

Call during normal business hours (8:30 am - 4:00 pm EST Monday through Friday) to speak with a knowledgeable representative.

FAX: 908-647-4242

MAIL AND SHIPPING: Elgee Manufacturing Co., Inc.
225 Stirling Road
Warren, NJ 07059

ELGEE POWER-VAC LIMITED WARRANTY

For ONE YEAR from date of installation for the original purchases, Elgee will repair or replace (at Elgee's option), FREE OF CHARGE, any parts or parts found upon examination by the factory in Warren, New Jersey, or by any factory authorized center, to be defective in material and/or workmanship.

Except for bags, wiring, fuel tubes, cables, brass nipples, and rubber parts, Elgee parts carry a ONE YEAR warranty against mechanical defects and workmanship. Should defects become evident, parts must be returned, prepaid, to our factory for inspection. Elgee will not be responsible for repairs made outside of the factory without authorization.

Charges for removal, reconnection, shipping and/or transportation of parts submitted for replacement under this warranty must be borne by the purchaser.

Any changes or modification of this unit without the expressed written consent of Elgee Manufacturing Co., Inc. will void this warranty.

Anything related to the conversion of an engine to propane fuel burning voids the manufacturer's warranty pertaining to any part directly associated with propane fuel combustion. All other engine components carry full manufacturer's warranty.

Engine warranty is carried by the manufacturer and their authorized dealers. Honda engines carry a TWO YEAR warranty. Briggs & Stratton offers a ONE YEAR warranty on their Industrial/Commercial (I/C) engines and their 6HP Intek engines. Their warranty for standard engines is 90 DAYS.

No warranty is expressed or implied. Elgee and any or all of its subcontractors shall in any event NOT be liable for consequential damages.

Implied warranties, including those of merchantability and fitness for a particular purpose, are limited to ONE YEAR from the date of purchase and to the extent permitted by law. Any and all implied warranties are excluded. This is the exclusive remedy and liability for consequential damages under any and all warranties. Warranties are excluded to the extent exclusion is permitted by law.