

BEFCO[®]

Operator's Manual

SICKLE BAR MOWERS

BSB-272, BSB-284, BSB-296

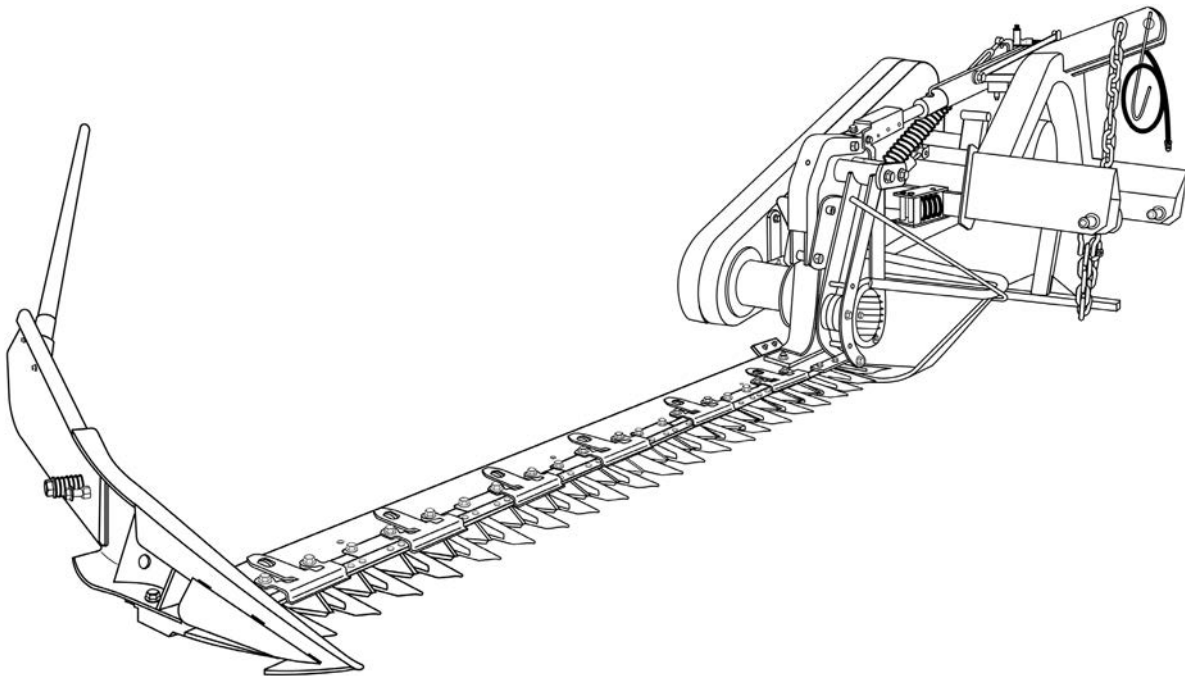

The operator's manual is a technical service guide and must always accompany the machine.

Manual 960-394B

December 2024

SAFETY

Take note! This safety alert symbol found throughout this manual is used to call your attention to instructions involving your personal safety and the safety of others. Failure to follow these instructions can result in injury or death.



*This symbol means:
ATTENTION!
BECOME ALERT!
YOUR SAFETY IS INVOLVED!*

Signal Words

Note the use of the signal words DANGER, WARNING and CAUTION with the safety messages. The appropriate signal words for each have been selected using the following guidelines:



DANGER: Indicates an imminently hazardous situation that, if not avoided, will result in death or serious injury.



WARNING: Indicates a potentially hazardous situation that, if not avoided, could result in death or serious injury, and includes hazards that are exposed when guards are removed. It may also be used to alert against unsafe practices.



CAUTION: Indicates a potentially hazardous situation that, if not avoided, may result in minor or moderate injury.

INDEX

1 - GENERAL INFORMATION	4
1.01 - General	4
1.02 - Warranty Information	4
1.03 - Model and Serial Number ID	5
2 - SAFETY PRECAUTIONS	6
2.01 - Preparation	6
2.02 - Starting and Stopping	6
2.03 - Messages and Signs	7
3 - OPERATION	10
3.01 - Operational Safety	10
3.02 - Setup	12
3.03 - Assembly Instructions	12
3.04 - Pre-Operational Check	14
3.05 - Attaching to the Tractor	15
3.06 - Start Up	16
3.07 - Working Speed	17
3.08 - Operating Techniques	18
3.09 - Uneven Terrain	23
3.10 - Hydraulic Cylinder Flow Valve Adjustment	23
3.11 - Angle of Cut	24
3.12 - Removing Mower from Tractor	24
3.13 - Transport	25
4 - MAINTENANCE	27
4.01 - Maintenance Safety	27
4.02 - Service	28
4.03 - Driveline	29
5 - REPAIR PROCEDURES	32
5.01 - Blade Replacement	32
5.02 - Suggested Spare Parts	35
5.03 - Storage	36
6 - TROUBLESHOOTING	37
7 - PRE-DELIVERY CHECKLIST	38
8 - WARRANTY	39
PARTS MANUAL	43

1 - GENERAL INFORMATION

Thank you and congratulations for having chosen our implement. Your new sickle bar mower is a technologically advanced machine constructed of high quality, sturdy components that will fulfill your working expectations. Read this manual carefully. It will instruct you on how to operate and service your implement safely and correctly. Failure to do so could result in personal injury and/or in equipment damage.

1.01 - General

The implement described in this manual is to be used with tractors with PTO at 540 rpm and clockwise rotation.



CAUTION: Always ensure that the coupling of the implement with the tractor is done at the same PTO speed and direction of rotation. Do not operate this implement at a PTO speed or direction of rotation other than that shown on the implement. Serious damage can occur to the machine and/or the operator.



CAUTION: Unless otherwise specified, all hardware is metric. Use only metric tools on metric hardware. Other tools that do not fit properly can slip and cause injury.



CAUTION: Right hand and left hand sides of the implement are determined by facing in the direction the implement will travel when going forward (see fig. 2).

1.02 - Warranty Information

Carefully read the Warranty section¹, detailing coverage and limitations of this warranty. **Warranty** is provided for customers who operate and maintain their equipment as described in this manual. Warranty registration is accomplished by the dealer by completing and forwarding the **Warranty Registration** form to the Company, along with a copy of the dealer's invoice. It is in your best interest to insure that this has been done.

Warranty does not cover the following:

1. Cleaning, transporting, mailing and service call charges.

¹ See Chapter 8 - Warranty.

2. Normal wear items such as belts, blades, bearings, drivelines, shear pins, slip clutches, etc.
3. Depreciation or damage caused by normal wear, accidents, improper maintenance, improper protection or improper use.
4. The use of non-original spare parts and accessories.

Your Authorized Company Dealer has genuine parts in stock. Only these approved replacement parts should be used.

This limited warranty covers defective material and workmanship. The cost of normal maintenance or repairs for accidents or improper use and related labor will be borne by the owner.

1.03 - Model and Serial Number ID

Attached to the frame is an ID plate showing the model and the serial number. Record your implement model and serial number in the space provided below. Your dealer needs this information to give you prompt, efficient service when you order parts.

BEFCO	1781 S. Wesleyan Blvd. – P.O. Box 6036 Rocky Mount, N.C. 27802 – U.S.A. Tel: 1.252.977.9920 Fax: 1.252.977.9718
MODEL:	
SERIAL:	
VERSION:	

2 - SAFETY PRECAUTIONS

Safety is the primary concern in the design and manufacture of our products. Unfortunately our efforts to provide safe equipment can be wiped out by a single careless act of an operator.

In addition to the design and configuration of equipment, hazard control and accident prevention are dependent upon the awareness, concern, prudence and proper training of personnel involved in the operation, transport, maintenance and storage of equipment. It is the operator's responsibility to read and understand all safety and operating instructions in the manual and to follow these.

Allow only properly trained personnel to operate the implement. Working with unfamiliar equipment can lead to careless injuries. Read this manual, and the manual for your tractor, before assembly or operation, to acquaint yourself with the machines. It is the owner's responsibility, if this machine is used by any person other than yourself, is loaned or rented, to make certain that the operator, prior to operating, reads and understands the operator's manuals and is instructed in safe and proper use.

2.01 - Preparation



1. Before operating equipment read and understand the operator's manual and the safety signs (**see fig. 2**).
2. Thoroughly inspect the implement before initial operation to assure that all packaging materials, i.e. wires, bands, and tape have been removed.
3. Personal protection equipment including hard hat, safety glasses, safety shoes, and gloves are recommended during assembly, installation, operation, adjustment, maintaining and/or repairing the implement.
4. Operate the implement only with a tractor equipped with an approved Roll-Over-Protective-System (ROPS). Always wear your seat belt. Serious injury or even death could result from falling off the tractor.
5. Clear area to be cut of stones, branches or other debris that might be thrown, causing injury or damage.
6. Operate only in daylight or good artificial light.
7. Ensure implement is properly mounted, adjusted and in good operating condition.
8. Ensure that all safety decals are properly installed and in good condition.

2.02 - Starting and Stopping



1. Be sure that no one is near the machine prior to engaging or while the machine is working.

2. Be sure the tractor is in "Neutral" before starting engine.
3. Never use the lifting controls when standing between the tractor and linkage.
4. Mower operating power is supplied from tractor PTO. Refer to your tractor manual for PTO engagement and disengagement instructions. Operate PTO at 540 rpm, never operate PTO at speeds above 540 rpm. Know how to stop the tractor and mower quickly in case of an emergency.
5. When engaging PTO, the engine rpm should always be low. Once engaged and ready to start cutting, raise PTO speed to 540 rpm and maintain throughout cutting operation.
6. Check the tractor master shield over the PTO stub shaft. Make sure it is in good condition and fastened securely to the tractor. Purchase a new shield if old shield is damaged or missing.
7. After striking an obstacle, disengage the PTO, shut the tractor down and thoroughly inspect for damage before restarting.
8. To park the vehicle safely, stop vehicle on a level surface (not on a slope), disengage PTO, engage the parking brake, stop the engine, remove the key, and wait for engine and all moving parts to stop before leaving the operator's seat.
9. Stay clear of rotating drivelines. Entanglement in rotating driveline can cause serious injury or death. Wear close fitting clothing. Stop the engine and be sure PTO driveline is stopped before getting near it.

2.03 - Messages and Signs



1. Read and adhere to all safety and operating decals on this machine (**see fig. 2**).
2. Before dismounting tractor: Allow moving parts to stop, stop engine, set brake and remove the key of unattended equipment.
3. Keep safety decals in place and in good condition.
4. Keep guards and shields in place and in good condition.
5. Do not use with bystanders in area.
6. Allow no riders on tractor or implement.
7. Allow moving parts to stop before repair.
8. Securely support implement before working underneath.

Additional warning and operating decals are available at no extra charge. Please specify model and serial number when ordering.

Safety decals - driveline; replace immediately if damaged.

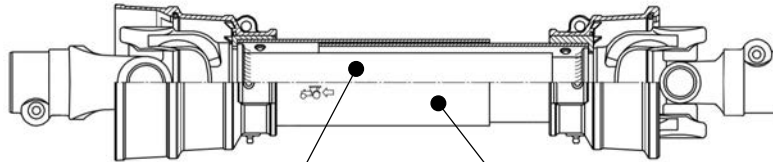

placed on outer tube



placed on outer shield

3 - OPERATION

You have purchased a sickle bar mower designed for the mowing of fields, ditch banks and along ponds. The sickle bar mowers can be used with tractors from 20 up to 75 HP and come in working widths of 72", 84" and 96". The double action sickle bar allows for a maximum working speed of up to 9 mph. Simple but tough construction along with a heavy duty PTO, weight compensation spring, transport blade guard and a safety release latch which protects the unit from obstructions in the field, all provide for a unit that will give years of trouble free service. Sickle bar mowers come standard with a hydraulic cylinder that makes it easy to raise the bar for mowing at an angle or for transport and storage. The capability of mowing from 90° up to -55° down along with the low horsepower requirements makes the sickle bar mower capable of handling jobs that are not recommended for conventional disc mowers.



WARNING: The sickle bar is suitable only for the uses indicated. Any other use different from that described in these instructions could cause damage to the machine and represent a serious hazard for the user.

3.01 - Operational Safety



CAUTION: Our mowers are designed considering safety as the most important aspect and are the safest available in today's market. Unfortunately, human carelessness can override the safety features built into our machines. Injury prevention and work safety, aside from the features on our mowers, are very much due to the responsible use of the equipment. It must always be operated prudently following with great care, the safety instructions laid out in this manual.



1. The use of this equipment is subject to certain hazards which cannot be prevented by mechanical means or product design. All operators of this equipment must read and understand this entire manual, paying particular attention to safety and operating instructions, prior to using.
2. Do not operate the tractor and implement when you are tired, sick or when using medication.
3. Keep all helpers and bystanders at least 50 feet from the implement. Only properly trained people should operate this machine.

4. Accidents are most likely to occur with machines that are loaned or rented to someone who has not read the operator's manual and is not familiar with the implement.
5. The majority of accidents involve entanglements on the driveline, injury of bystanders from the mower blades, and operators being knocked off the tractor by low hanging limbs and then being run over by the mower. Accidents are most likely to occur with machines that are loaned or rented to someone who has not read the operator's manual and is not familiar with a sickle bar mower.
6. Always stop the tractor, set brake, shut off the tractor engine, remove the ignition key, lower implement to the ground and allow mower blades to come to a complete stop before dismounting tractor. Never leave equipment unattended with the tractor running.
7. Never place hands or feet near mower with tractor engine running or before you are sure all motion has stopped. Stay clear of all moving parts.
8. Do not allow riders on the mower or tractor at any time. There is no safe place for riders.
9. Do not operate unless all personnel, livestock and pets are at least 50 feet away to prevent injury by thrown objects.
10. Before backing up, disengage the mower and look behind carefully.
11. Install and secure all guards and shields before starting or operating.
12. Keep hands, feet, hair and clothing away from moving parts.
13. This mower is designed for use only on tractors with 540 rpm power take off.
14. Never operate tractor and mower under trees with low hanging limbs. Operators can be knocked off the tractor and then run over by the mower blades.
15. The moving parts of this machine have been designed and tested for rugged use. However, they could fail upon impact with heavy, solid objects such as steel guard rails and concrete abutments. Such impact could cause the broken objects to be thrown outward at very high velocities. To reduce the possibility of property damage, serious injury, or even death, never allow the cutting blades to contact such obstacles.
16. Frequently check mower blades. They should be sharp, free of nicks and cracks and securely fastened.
17. Stop mower immediately upon striking an obstruction. Turn engine off, remove key, inspect and repair any damage before resuming operation.
18. Stay alert for holes, rocks and roots in the terrain and other hidden hazards. Keep away from drop-offs.
19. Use extreme care and maintain minimum ground speed when transporting on hillside, over rough ground and when operating close to ditches or fences. Be careful when turning sharp corners.
20. Reduce speed on slopes and sharp turns to minimize tipping or loss of control. Be careful when changing directions on slopes. Do not start or stop suddenly on slopes. Avoid operation on steep slopes.
21. When using a unit, a minimum 20% of tractor and equipment weight must be on tractor front wheels. Without this weight, tractor could tip over, causing personal injury or death. The weight may be attained with a front end loader, front wheel weights, ballast in tires or front tractor weights. When attaining a minimum 20% of

- tractor and equipment weight on the front wheels, you must not exceed the ROPS weight certification. Weigh the tractor and equipment. Do not guess or estimate!
22. Inspect the entire machine periodically². Look for loose fasteners, worn or broken parts, and leaky or loose fittings.
 23. Use only the driveline supplied with the mower. Do not use it if it is missing any shield or safety protection.
 24. Pass diagonally through sharp dips and avoid sharp drops to prevent "hanging up" tractor and mower.
 25. Avoid sudden starts and stops while traveling up or downhill.
 26. Always cut down slopes; never across the face. Avoid operation on steep slopes. Slow down on sharp turns and slopes to prevent tipping and/or loss of control.

3.02 - Setup

Notice to dealer: Pre-delivery setup and service including lubrication is the responsibility of the authorized dealer. It is up to him to assure that the machine is in perfect condition and ready to be used. It is his responsibility to ensure that the customer is aware of all safety aspects and operational procedures for the mower. He must also fill out the Pre-Delivery Checklist³ prior to delivering the mower.

3.03 - Assembly Instructions

The BSB-272, 284 and 296 series sickle bar mowers are shipped almost completely assembled and individually crated. Follow the instructions below to assemble remaining items on the sickle bar mower.

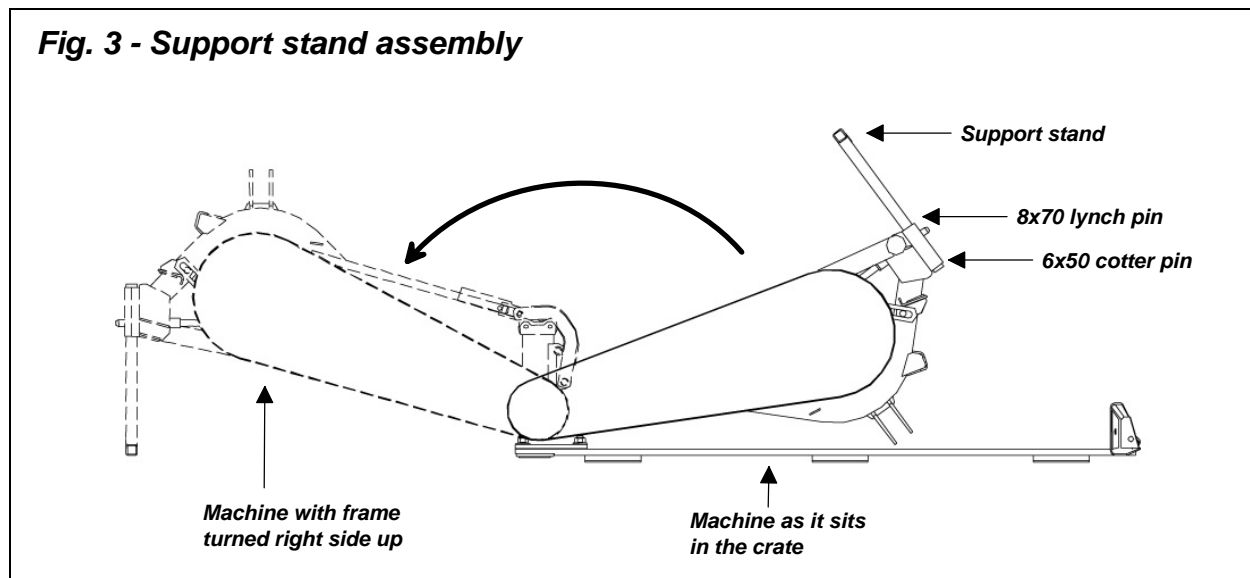

² See Chapter 4 - Maintenance.

³ See Chapter 7 - Pre-Delivery Checklist.



CAUTION: Stand clear of bands when cutting as they could be under sufficient tension to cause them to fly loose. Take care in removing bands and wire. They often have extremely sharp edges and cut very easily.

To assemble the sickle bar mower proceed as follows:

1. Using a screwdriver, remove the screws on the side of the crate securing the top lid then remove the top lid.
2. Remove the screws on the side securing the sides of the crate to the bottom pallet then remove the sides.
3. Using a hoist, secure it to the sickle bar mower, lift the mower off the bottom pallet and remove the pallet from under it. Lower the mower until the cutting bar is resting on the ground.
4. Assemble the support stand to the machine using the $\text{\O}6 \times 50$ cotter pin and the $\text{\O}8 \times 70$ lynch pin (**see fig. 3**).
5. Using a hoist, secure it to the three point hitch and frame and gradually lift and turn the three point hitch and frame until they are the right side up. With the support stand secured to the frame, allow the frame to rest on the stand (**see fig. 3**).
6. Assemble the stop bar through the hole on the support, place the $\text{\O}20$ flat washer and secure using the $\text{\O}6 \times 32$ roll pin (**see fig. 4**).

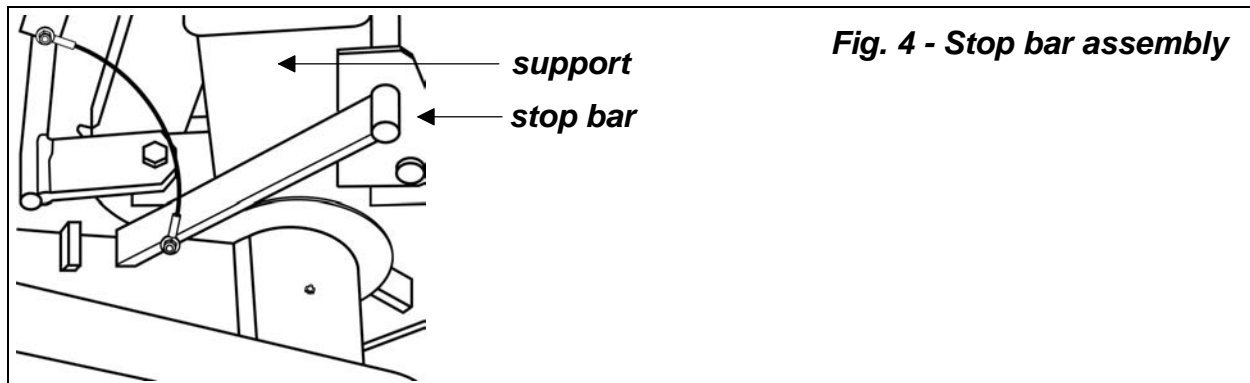

7. Using the six belt shield brackets, assemble the outer belt shield. Position all the belt shield brackets so that the side with the 25mm long thread is assembled towards the inner belt shield, secure all six brackets using the $\text{\O}10$ conical spring washers and the M10 HH nuts. (**see fig. 5**).
8. Position the outer belt shield over the belt shield brackets and secure it in place using the $\text{\O}10$ spring washers and the M10 ES nuts (**see fig. 5**).
9. Assemble the skids to the cutting bar using the $\text{\O}10$ spring washers and secure them with the M10x30 bolts (**see fig. 6**).
10. Secure the swath board to the outer guard support using the M12x80 carriage bolt (**see fig. 6**).
11. Using a rubber mallet, drive the wide end of the deflector stick into the stick holder on the swath board (**see fig. 6**).

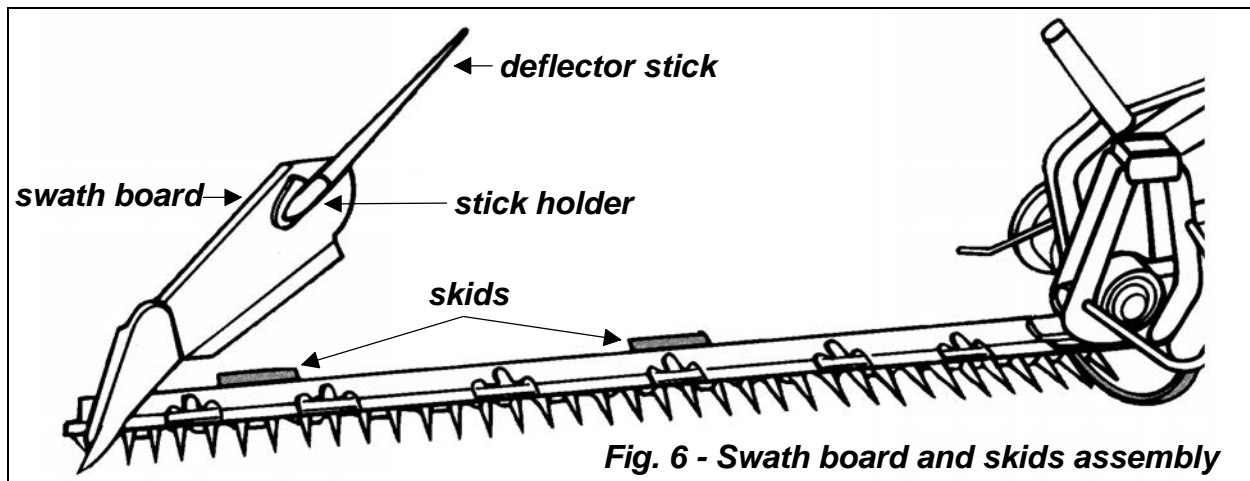
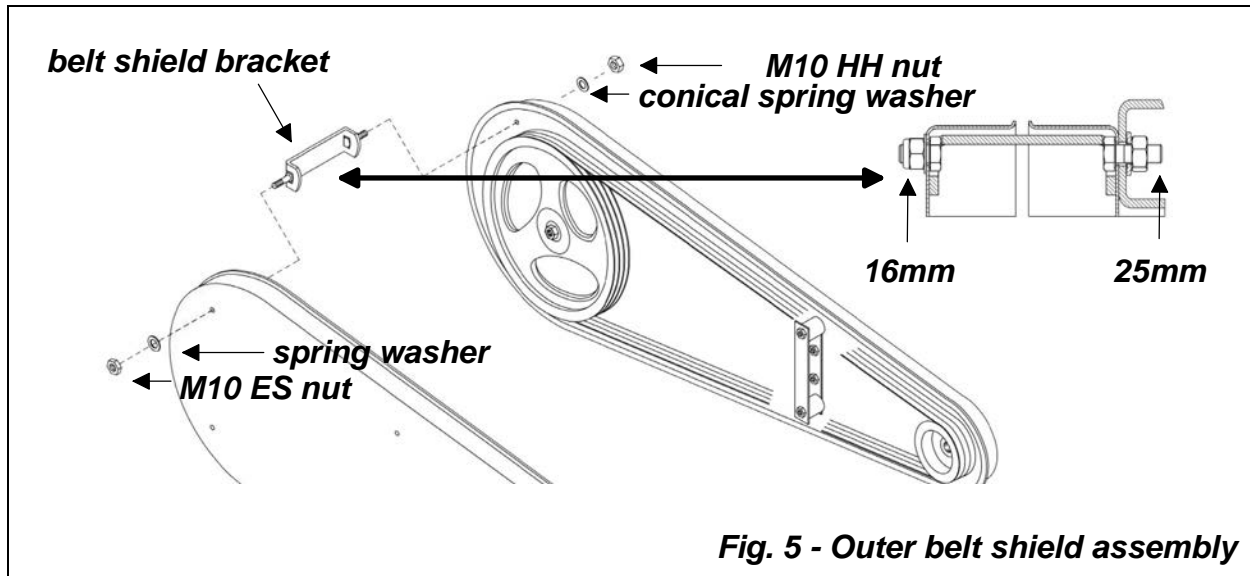

3.04 - Pre-Operational Check

IMPORTANT: Check each of the following, carefully, prior to engaging the equipment:

1. All lubrication points have been greased.
2. The belts for proper tension.
3. The driveline cross and bearings have been greased.
4. No wrappings or foreign objects are around the cutting bar, belts or driveline.
5. The blades are properly installed.
6. All hardware is tight.
7. The tractor, to ensure correct direction of PTO and rpm speed.
8. All safety shields and guards are in place and tightly attached.
9. No people or animals are in the work area.
10. When working, make sure the tractor hitch is in the "float" position, in order to allow the mower to follow the contour of the ground.



DANGER: Stay clear of rotating driveline. Entanglement in rotating driveline can cause serious injury. Disengage PTO, engage parking brake or place transmission in “Park”, shut off the tractor and remove the key before working around hitch, attaching or detaching driveline, making adjustments, servicing or cleaning the machine.

3.05 - Attaching to the Tractor

Models BSB-272, 284 and 296 may be used on tractors ranging from 20 to 75 HP equipped with a standard PTO and a category 1 three point hitch or a category 1 Quick-Hitch⁴. **Never use this mower with tractors over 75 HP.**



CAUTION: Check the tractor PTO rpm to ensure it is set at 540 and turns clockwise.



CAUTION: Always ensure that the tractor tire pressure is correct according to the tractor operator's manual.



DANGER: Failure to ensure a secure coupling of the implement to the tractor can cause injury and damage to the implement or tractor.

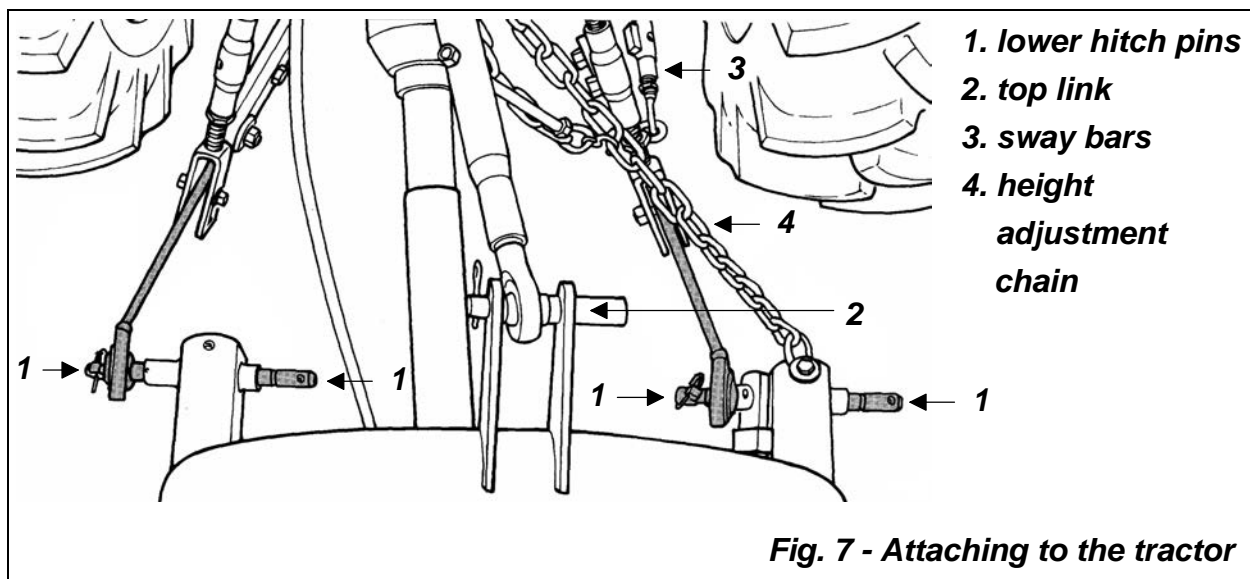

⁴ See Table 2 - Technical Features, page 31.

To attach the sickle bar mower to the tractor proceed as follows (**see fig. 7**):

1. Back the tractor to the mower until the lower link arms align with the lower hitch pins.
2. Stop engine, engage parking brakes and remove key before dismounting tractor.
3. Secure the lower link arms to the hitch pins and secure them in place with lynch pins.
4. Attach top link to the top hitch of the sickle bar mower using the hitch pin and secure it with the cotter pin.
5. Adjust the tractor sway chains/bars to secure the implement behind the tractor and control the side sway.
6. Ensure the sickle bar mower is leveled by adjusting both the lower link arms and the top link.
7. Install the driveline and make sure it is locked securely on the tractor's PTO and on the implement prior to engagement. Connect the driveline shielding chains to the tractor and to the implement to prevent the protective shielding from rotating during operation. If it was necessary to remove the PTO shielding to do any of the above operations, do not forget to replace it. Ensure that the driveline has at least 2" from bottoming out in its shortest working position and has the minimum 6" overlap in its longest working position. Refer to **Section 4.03⁵** of this manual if it is determined that the driveline is too long and needs to be shortened. Contact your local dealer if it is determined that the driveline is too short for your tractor.
8. Connect the hydraulic remote on the sickle bar into the tractors hydraulic system.
9. Raise sickle bar. Remove the Ø8x70 lynch pin that retains the support stand, raise the support stand and secure it again with the pin.
10. Disengage the float lock so that it sits in the mowing position (**see fig. 10**).
11. Remove the transport lock rod by removing the wing nut (**see fig. 12**) and rest the rod in the supplied position on the sickle bar.
12. Remove the guard over the cutting blades.

Note: For serial numbers 317910 & below, when using our sickle bar with a tractor equipped with a quick hitch, operator will need to remove the clamp that secures the chain to the implement and place it on the outer right bottom hitch pin. This is necessary because the bottom right hook of the quick hitch connects to the frame of the sickle bar mower in the same position where the clamp is originally located.

3.06 - Start Up



DANGER: Never stand between the tractor and implement to operate the lifting controls of the tractor from outside of the driver's seat.

Lower mower to the ground with the tractor rock shaft control lever. With the engine idling, slowly engage the PTO drive. Move the throttle lever until the PTO speed indicated on the mower is obtained. The mower is set for a PTO speed of 540 rpm.

⁵ See Section 4.03 - Driveline, for instructions on how to determine correct driveline length and procedures for shortening the driveline.

Shift the transmission to a slow speed gear and start forward, increase the ground speed by shifting upward until the desired speed is obtained.



CAUTION: Do not operate this mower at a PTO speed or direction of rotation other than that shown on the mower. Serious damage can occur to the machine and/or the operator.

Before starting to mow, never forget that the **operator is responsible** for the following:

1. Safe and correct driving of the tractor and mower.
2. To learn precise safe operating procedures for both the tractor and the mower.
3. To ensure all maintenance and lubrication has been performed on the mower.
4. To have read and understood all safety aspects for the mower in the operator's manual.
5. To have read and understood all safety decals on the mower.
6. Checking the condition of the blades. Worn or damaged blades should be changed before starting.
7. Checking that there is no wire, weed, grass or other material wrapped around blades.
8. Checking to see if front weights need to be added to the tractor in order to maintain balance.
9. Checking the tractor tires for the proper pressure in accordance with the tractor operator's manual.
10. **Checking that the PTO shield, belt shields and all other shielding are on the machine and securely in place.**
11. Making sure the proper attire is worn. Avoiding loose fitting clothing which can become entangled. Wearing sturdy, tough-soled work shoes and protective equipment for eyes, hands, ears and head. Never operate tractor or implements in bare feet, sandals or sneakers.
12. Checking area for stones, branches and other debris that might be thrown.
13. Ensuring proper lighting is available, sunlight or good artificial lighting.

3.07 - Working Speed

All of the following factors are important in selecting the proper forward speed:

1. Height of grass.
2. Type of grass.
3. Density of grass.
4. Type of terrain.
5. Grass condition, wet or dry.

The mowing speed depends on ground conditions, tractor HP, mowing height, and grass thickness. Only a test run will enable you to gauge the optimal working speed for your conditions. Under most conditions a 6 to 7 mph ground speed is best. For a good quality cut it is recommended to keep a steady work speed no slower than 5 mph. This

will facilitate grass discharge. Working speed should never exceed 9 mph to avoid damage to the unit.

In order to avoid clogging up of blade or if grass is tangled or flattened it is recommended to keep the cutting bar grazing the ground.

In order to obtain the best cut possible, always keep the tractor rpm up to the speed indicated on the mower. When increasing or decreasing mowing ground speed, always use gear selection, not engine speed. This will maintain the constant maximum blade speed necessary for a clean cut.

3.08 - Operating Techniques



DANGER: If blades become jammed it is advisable to operate carefully, wearing adequate personal protection before attempting to free them from obstruction.

Under most working conditions operate PTO at 540 rpm. This is necessary to maintain proper blade speed, obtain a clean cut and reduce the risk of jamming the blades. Always raise the implement before reversing or changing direction.

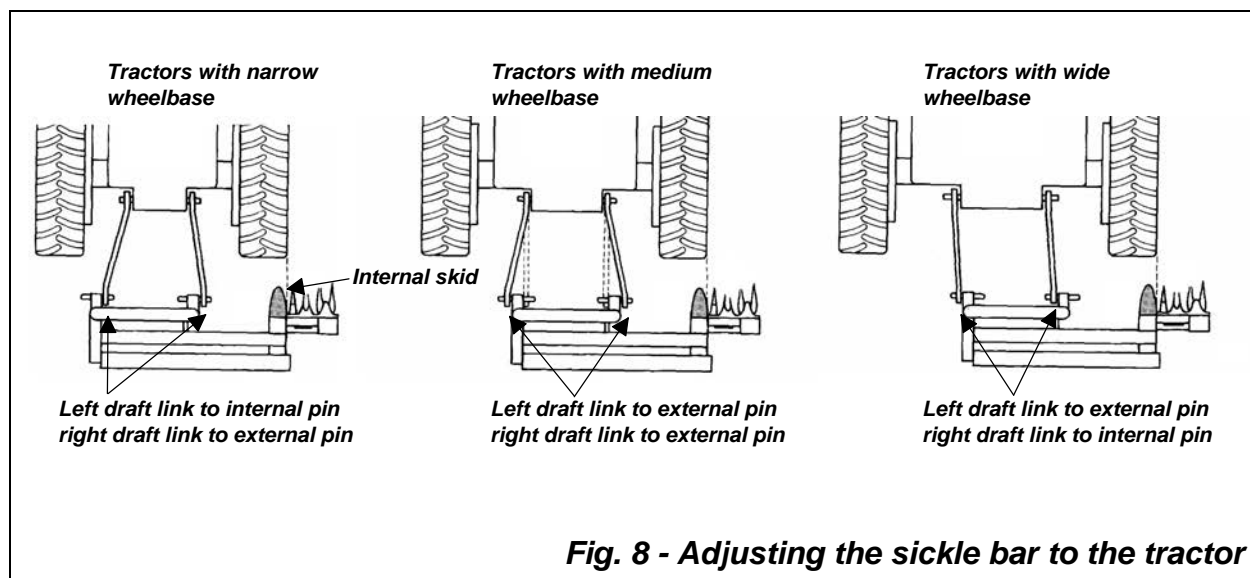

Adjusting the sickle bar

To ensure optimum use, the cutting bar of the mower must be able to extend beyond the width of the tractor tires. The offset on our sickle bars can be adapted to line up as much as possible to the outside of your right tractor tire. This is done by securing the lower link arms on the tractor to the internal or external hitch pins (**see fig. 8**). Assemble the cutting bar away from the three point hitch when mowing with tractors with a wide wheelbase and closer to the three point hitch when mowing with tractors with a narrow

wheelbase. Ideally the cutting bar should begin just outside the outer edge of the right tire while the internal skid should line up behind the tire.

Working Position

Raise the stand, remove the blade guard from the cutting bar, remove the transport lock rod (see fig. 12), disengage the float lock (see fig. 10), lower cutting bar, fit the sickle bar by adjusting the tractor stabilizer bars so that when sickle bar is attached to the three points on the tractor, the external tip of the cutting arm is approximately 2" forward with respect to the arm base.

To set the height of the sickle bar mower use the chain near the lower hitch pin of the mower and attach the appropriate link through the hole on the tractor coupling plate provided with the mower (see fig. 9). It is advisable to mark the link used so that the same position may be used each time the sickle bar is fitted to the tractor. Level the cutting bar by using the turnbuckle (see fig. 9).

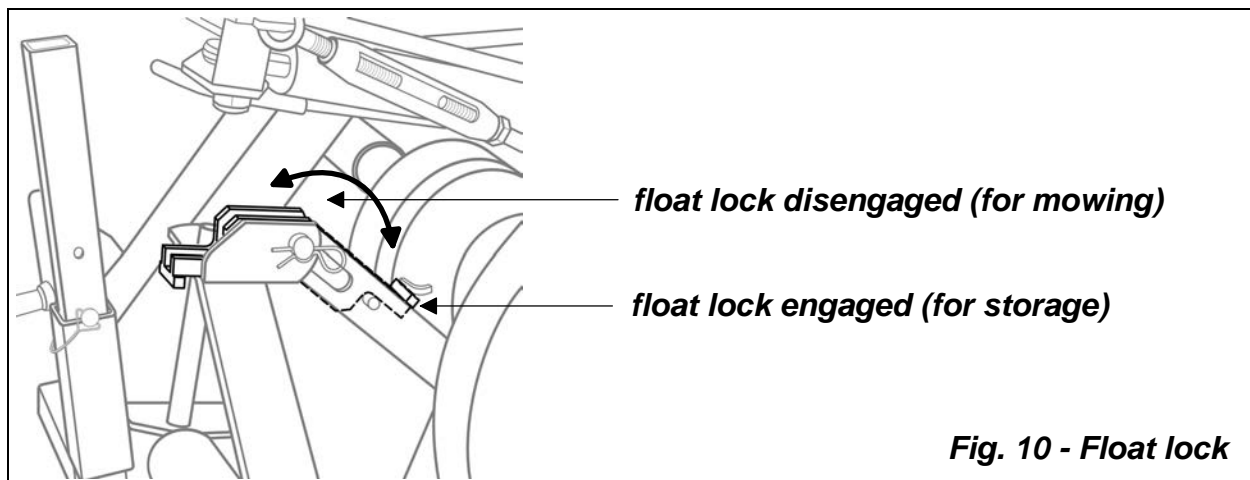
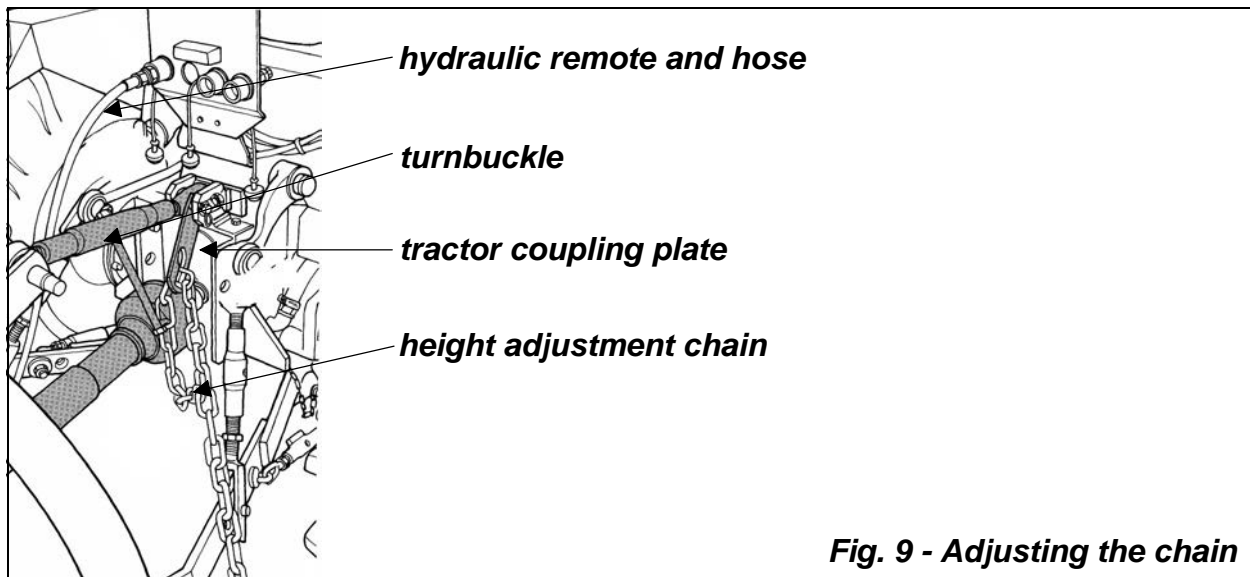

If the chain is set properly, the stop bar should have approximately 1" to 1-1/4" of travel before touching the stop welded to the frame (**see fig. 14**). Never operate the sickle bar with the three point hitch close to the ground as this could cause damage to the frame and/or the hydraulic cylinder.

Operating the sickle bar

During operation make sure to set the tractor hitch in the "float" position so that the weight of the mower is supported by the chain. This will help the mower follow the contour of the ground.

The swath board allows operator to adjust the windrow width (**see fig. 11**). Use the bolt and lock nut on the swath board to adjust the opening angle of the swath board. Closing the angle on the swath board will reduce the windrow width while opening it will increase the windrow width. If the grass is very thick, a swath board that is too closed could cause the hay to clump up. The deflector stick at the end of the swath board gently folds the mowed hay to the side. Raise the deflector stick when hay is taller and lower it when it is shorter.

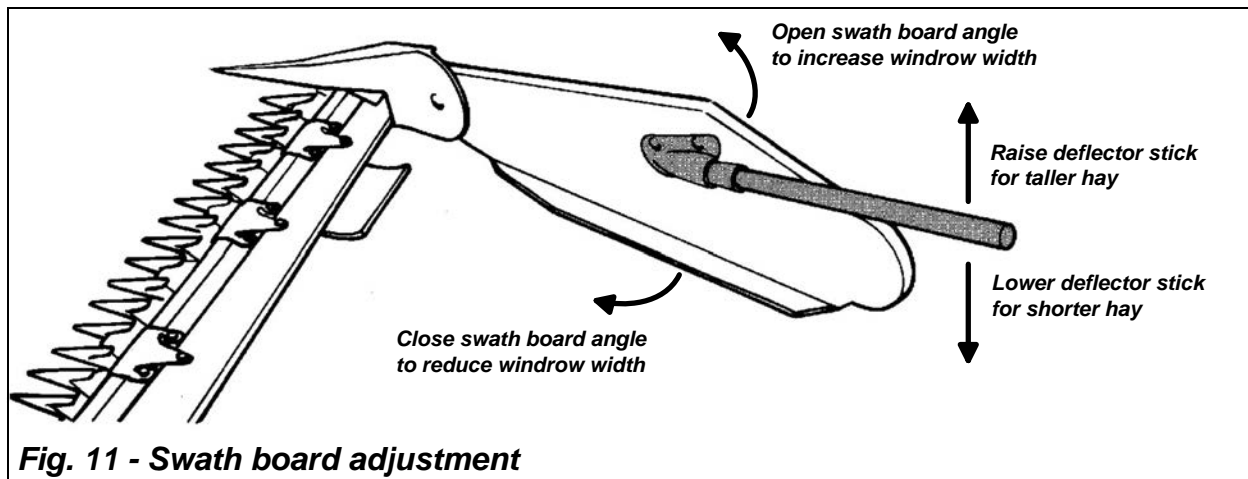

Fig. 11 - Swath board adjustment

Raising and lowering of the cutting bar

Raising and lowering the cutting bar is performed by a single action hydraulic cylinder supplied with flow valve adjustments⁶ that require a single remote on the tractor to be able to work.

Our sickle bar mowers are equipped with a transport lock rod that the operator needs to engage anytime the machine is being transported or stored for any length of time:

- To engage the transport lock rod, raise the cutting bar to 90°, position the rod through the hole on the cutting bar and secure it with the wing nut (**see fig. 12**).
- To disengage the transport lock rod, remove the wing nut and place the transport lock rod in its resting position on the unit then secure the wing nut on the threaded rod.

⁶ See Section 3.10 - Hydraulic Cylinder Flow Valve Adjustments, for more information on how to operate the flow valves.

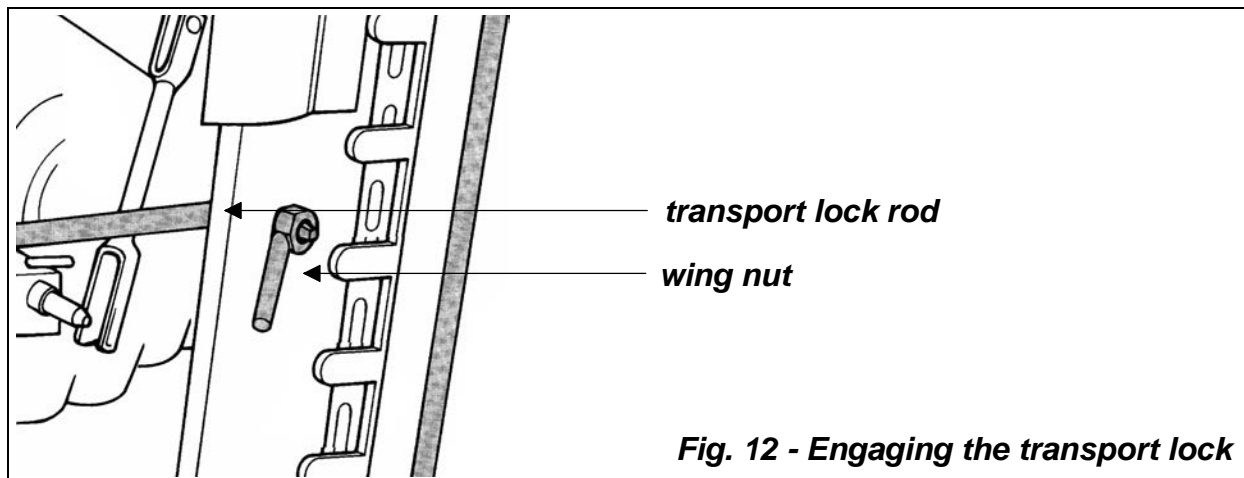

Fig. 12 - Engaging the transport lock

Cutting bar raise lock

Sickle bar mowers are equipped with a cutting bar raise lock (see fig. 13). This lock allows operator to raise the cutting bar from the ground, using the tractor hydraulic remote and turn around so that end of field maneuvers can be carried out without ever having to raise the three point hitch. Once the tractor is turned around, operator lowers the cutting bar and resumes mowing. The cylinder stop bracket is connected to the stop bar by a metal wire. When the cylinder stop is in the working position, the stop bar should be resting on the frame with approximately 1 to 1-1/4" travel from the welded stop (see fig. 14).

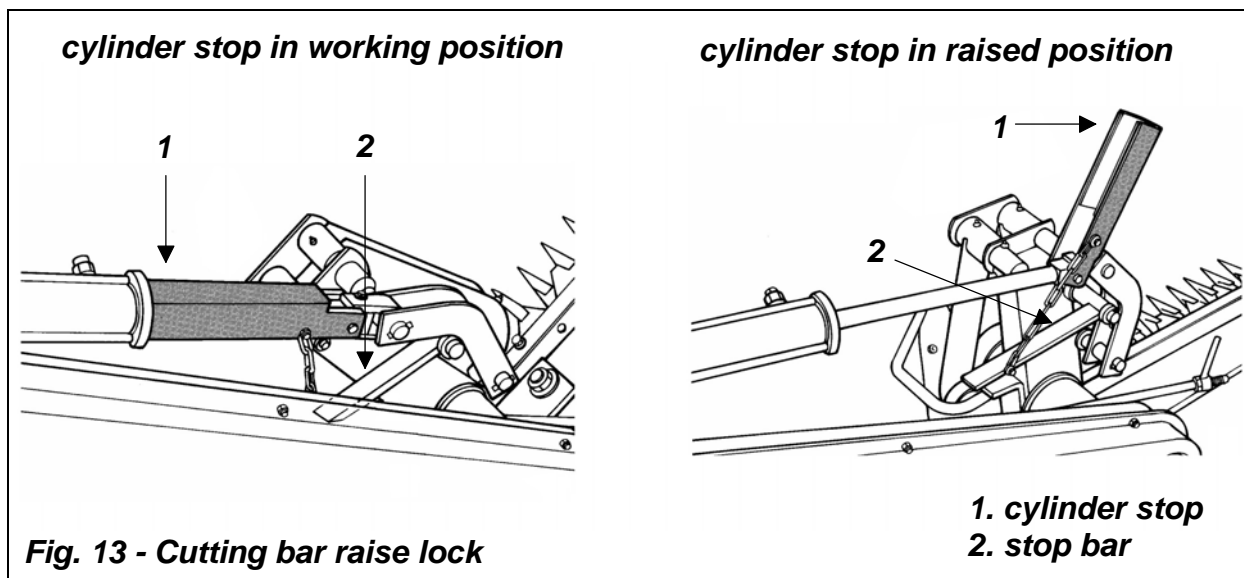

Fig. 13 - Cutting bar raise lock

- 1. cylinder stop
- 2. stop bar

IMPORTANT: To use the cutting bar raise lock mechanism ensure that the cylinder stop is resting on the cylinder rod (see fig. 13).

NOTE: When mowing over uneven terrain it is advisable to keep cutting bar raise lock in raised position (see fig. 13).

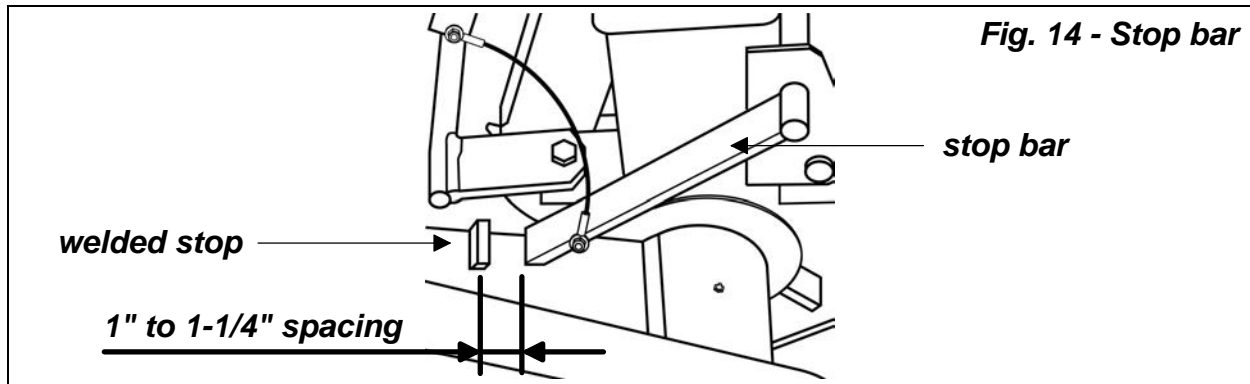

Fig. 14 - Stop bar

Safety release latch

The sickle bar mower is protected with a safety release latch mechanism (see fig. 15). If the cutter bar is driven into a foreign object such as a tree or a pole, the safety release mechanism will allow the cutter bar to swing back to help avoid major damage to the unit.

In the event of a collision with a foreign object, immediately stop the tractor, do not raise sickle bar. Turn off tractor engine and make sure the driveline halves have not become separated, if so, reassemble the two driveline halves. Once you have inspected the unit, return to the tractor seat, turn on the engine, and reset the safety release by backing up tractor until latch returns to its normal position.

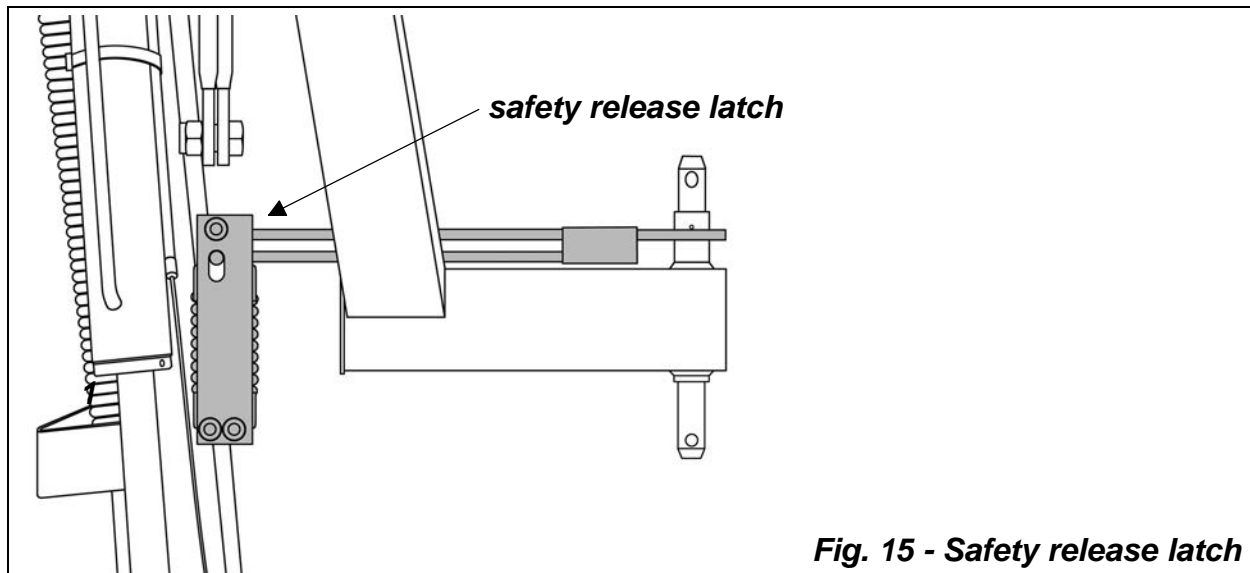

Fig. 15 - Safety release latch



DANGER: The mower blades can throw objects up to 50 feet which could result in personal or property damage. Pick up all rocks and other debris before mowing. Enter new areas carefully. Cut grass higher at first, allowing mower to clear hidden objects.



CAUTION: For emergency reasons learn how to stop the tractor and mower quickly. On the sickle bar mower always disengage the PTO, lock parking brake, stop engine and allow the blades to come to a complete stop before dismounting the tractor.

3.09 - Uneven Terrain



DANGER: Be careful of rollover when operating tractor and implement over uneven ground.

The following precautions should always be observed when working on uneven terrain:

1. In extremely uneven terrain rear wheel weights, front tractor weights, and/or tire ballast should be used to improve stability.
2. Observe the type of terrain and develop a safe working pattern.
3. Whenever traction or stability is doubtful, first test drive over the terrain with the PTO disengaged.
4. Operate the implement up and down steep slopes, not across slopes, to prevent the tractor from tipping. Avoid sudden stops and starts, slow down before changing directions on a slope.
5. Pass diagonally through sharp dips and avoid sharp drops to prevent hanging up the tractor and implement.
6. Slow down on sharp turns and slopes to prevent tipping or loss of control.
7. Watch for holes, roots or other hidden objects.

3.10 - Hydraulic Cylinder Flow Valve Adjustment

Sickle bar mowers are equipped with a flow adjustment valve that allows operator to adjust the speed at which the cutting bar is lowered.

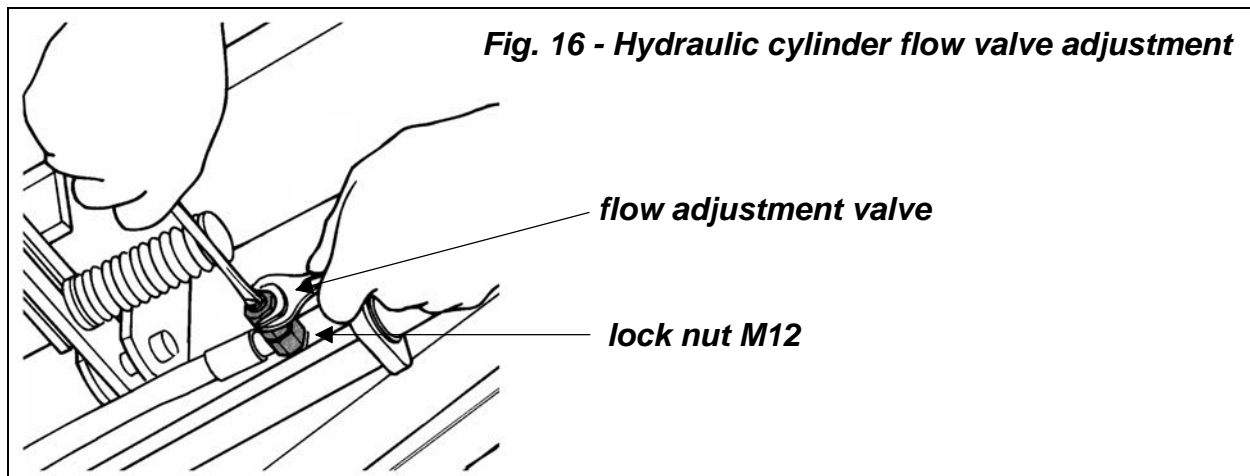

To adjust lowering speed of the cutting bar proceed as follows: If descend speed of cutting bar is too fast, loosen the M12 lock nut then, using a screwdriver, turn the flow adjustment valve clockwise (**see fig. 16**). This will gradually reduce oil flow and consequently reduce descending speed. Once the desired lowering speed is obtained, tighten the M12 lock nut to allow flow adjustment valve to remain in the desired position.

3.11 - Angle of Cut

The sickle bar mower is designed to work on any type of lawn and to work on banks and ditches from 90° up to -55° down (**see fig. 17**).

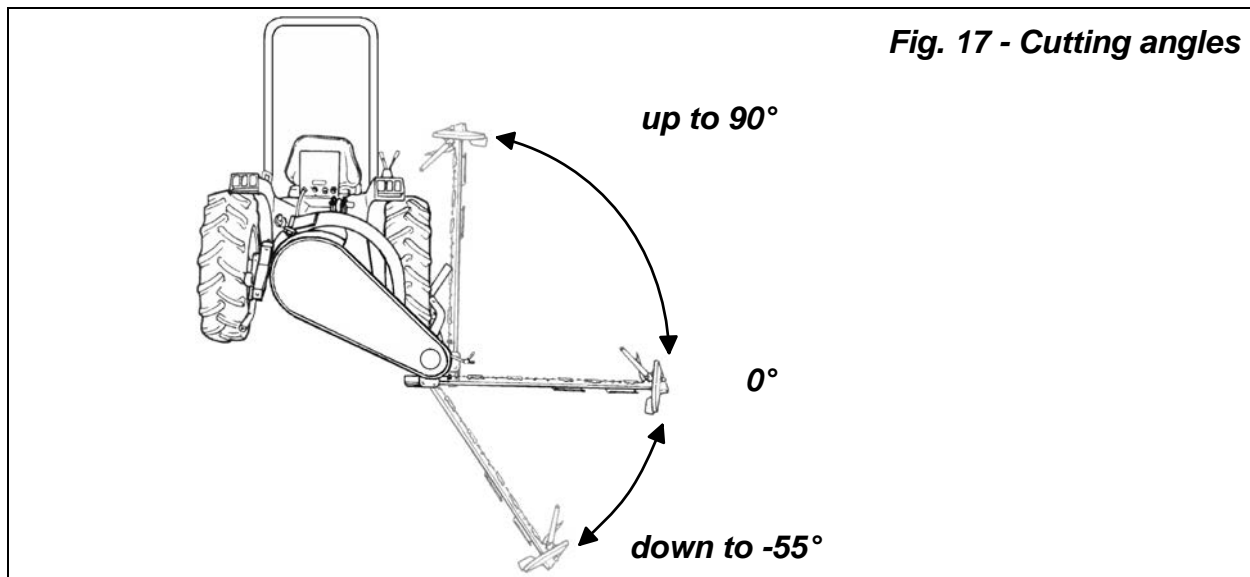

3.12 - Removing Mower from Tractor



DANGER: Avoid injury from blade. Always replace blade guard on cutting bar when mower is not in use.

To remove the mower from the tractor do the following:

1. Set up sickle bar on level and solid ground.
2. Disengage tractor PTO.
3. Set parking brake.
4. Engage the float lock so that it sits in the storage position (**see fig. 10**).
5. Replace blade guard on cutting bar.
6. Raise the sickle bar.
7. Engage transport lock rod and secure it with the wing nut (**see fig. 12**).
8. Put support stand in position and secure with pin.
9. Lower sickle bar to the ground.

10. Stop engine and remove key from ignition.
11. Disconnect the hydraulic remote from the tractor.
12. Disconnect mower driveline from tractor PTO shaft.
13. Disconnect three point linkage and carefully drive tractor away from mower.



CAUTION: Disengage tractor PTO. Set parking brake. Stop engine and remove key from ignition. Disconnect mower driveline from tractor PTO shaft. Collapse driveline and allow it to rest on the hook of the hitch pin. Disconnect three point linkage and carefully drive tractor away from mower.

3.13 - Transport

Before transporting:

Adjust and fix the stabilizer bars of the side lifting arms of the tractor. Lift the cutting bar and replace the transport lock rod (**see fig. 18**). Replace the blade guard on the cutting bar. Lift implement and place the hydraulic lifting command lever in locked position. Always select a safe ground speed that is appropriate for the terrain. Beware of traffic on public roads. Install a SMV (Slow Moving Vehicle) sign when traveling on roads or streets. Reduce ground speed when turning and take care that the mower does not strike obstacles such as trees, fences or buildings.



CAUTION: Make sure PTO is disengaged and blades have come to a complete stop before raising mower to full transport position. Do not tow tractor and mower behind other vehicles. Use a properly equipped trailer with heavy tie-downs for towing operations.

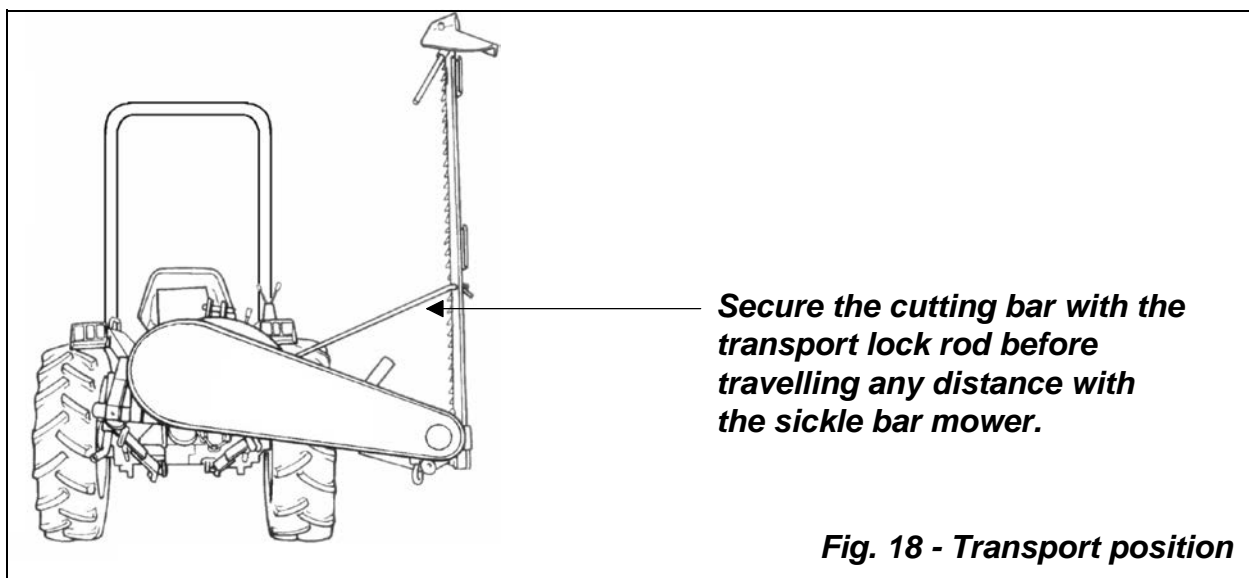

If it is necessary to load the sickle bar mower on a truck, tie one strap around the top link of the mower and another one to the supplied hole on the outer bar support. Adjust the length of the straps to remove any slack and secure them to the hook on the hoist. **(see fig. 19)**. Ensure that the load bearing capacity of the straps is sufficient to hold the weight specified in the technical features table for the machine⁷. Slowly raise the unit to make sure the weight is balanced correctly.

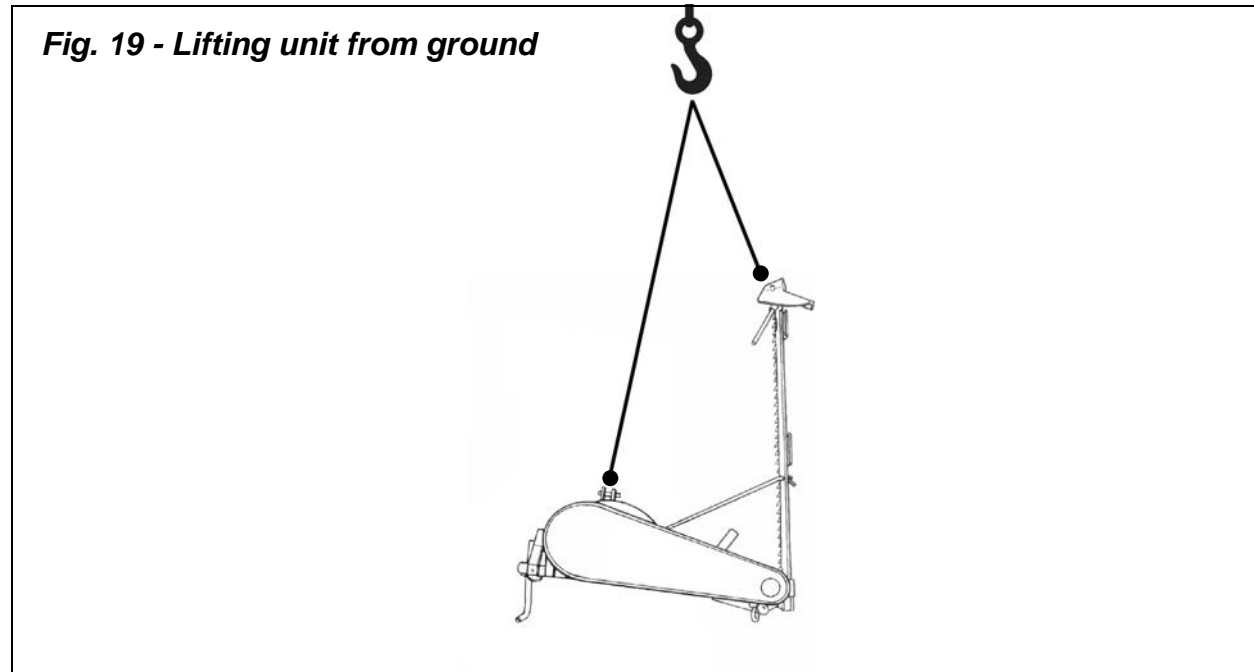

⁷ See Table 2 - Technical Features, page 31.

4 - MAINTENANCE



DANGER: Stop engine, lock parking brake and remove key before performing any service or maintenance.

Never rely on the tractor lift system. Install blocks or stands under the implement to prevent it from falling.

Always use personal protection devices, such as glasses or gloves when performing maintenance.

Keep fingers out of slots to prevent injury.

4.01 - Maintenance Safety



1. Good maintenance is your responsibility.
2. Keep service area clean and dry. Be sure electrical outlets and tools are properly grounded. Use adequate light for the job at hand.
3. Make sure there is plenty of ventilation. Never operate the engine of the towing vehicle in a closed building. The exhaust fumes may cause asphyxiation.
4. Make no repair or adjustments with the tractor engine running. Before working on the machine, disengage the PTO, shut off the engine, set the brakes, and remove the ignition key.
5. Be certain all moving parts on attachment have come to a complete stop before attempting to perform maintenance.
6. Never work under equipment unless it is blocked securely.
7. Always use personal protection devices such as eye, hand and hearing protectors, when performing any service or maintenance.
8. Frequently check mower blades. They should be sharp, free of nicks and cracks and securely fastened.
9. Periodically tighten all bolts, nuts and screws and check that all cotter pins are properly installed to ensure unit is in a safe condition.
10. When completing a maintenance or service function, make sure all safety shields and devices are installed before placing unit in service.
11. After servicing, be sure all tools, parts and service equipment are removed.
12. Never replace hex bolts with less than grade five bolts unless otherwise specified, i.e. shear bolts⁸.
13. Where replacement parts are necessary for periodic maintenance and servicing, genuine replacement parts must be used to restore your equipment to original

⁸ Refer to Table 1 - Torque Specifications, page 31.

specifications. The company will not claim responsibility for use of unapproved parts and/or accessories and other damages as a result of their use.

14. Unauthorized modifications to the machine may impair the function and/or safety of the machine and reduce its life. If equipment has been altered in any way from original design, the manufacturer does not accept any liability for injury or warranty.

4.02 - Service

The chart below gives the frequency of lubrication in hours, based on normal operating conditions. Severe or unusual conditions may require more frequent lubrication.

Use a good quality SAE multipurpose type grease for all locations shown. Be sure to clean fittings thoroughly before using grease gun.

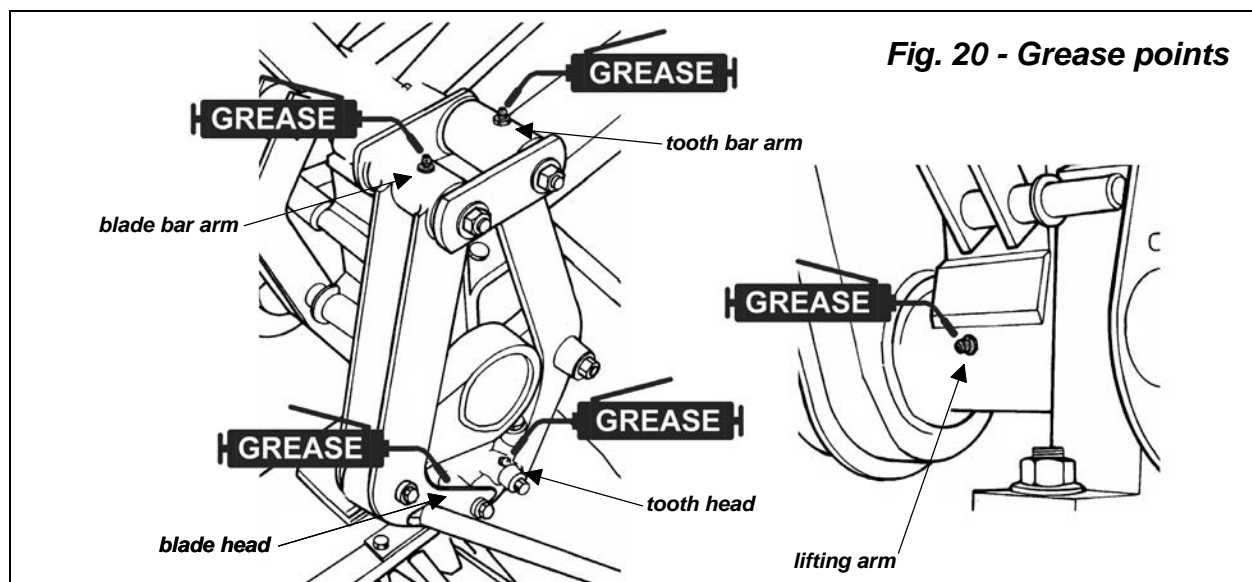

After each mowing job:

Clean unit and apply lubricating spray to the cutting blades to prevent rusting.

Every 8 hours:

1. Grease points on blade head and tooth head (see fig. 20).
2. Grease driveline (see fig. 21).
3. Check belt tension and, if necessary, adjust it (see fig. 22).

Every 25 hours:

Hardware tightness: vibration can loosen bolts. Check tightness of the hardware periodically⁹.

Every 50 hours:

1. Grease points on blade bar arm and tooth bar arm, grease point on lifting arm (see fig. 20).
2. Sharpen or replace worn cutting blades.

⁹ Refer to Table 1 - Torque Specifications, page 31.

Once a year or every 150 hours:

Replace the wear plate between the blade section and the tooth section.

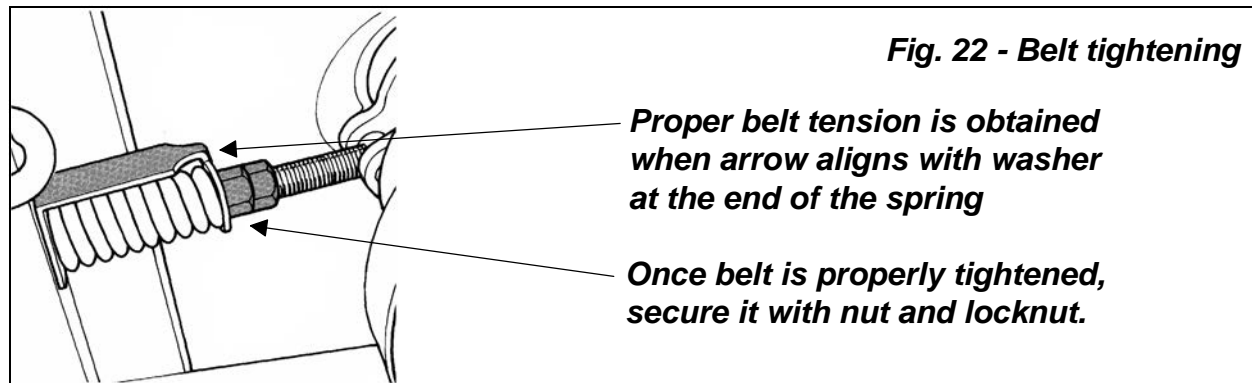
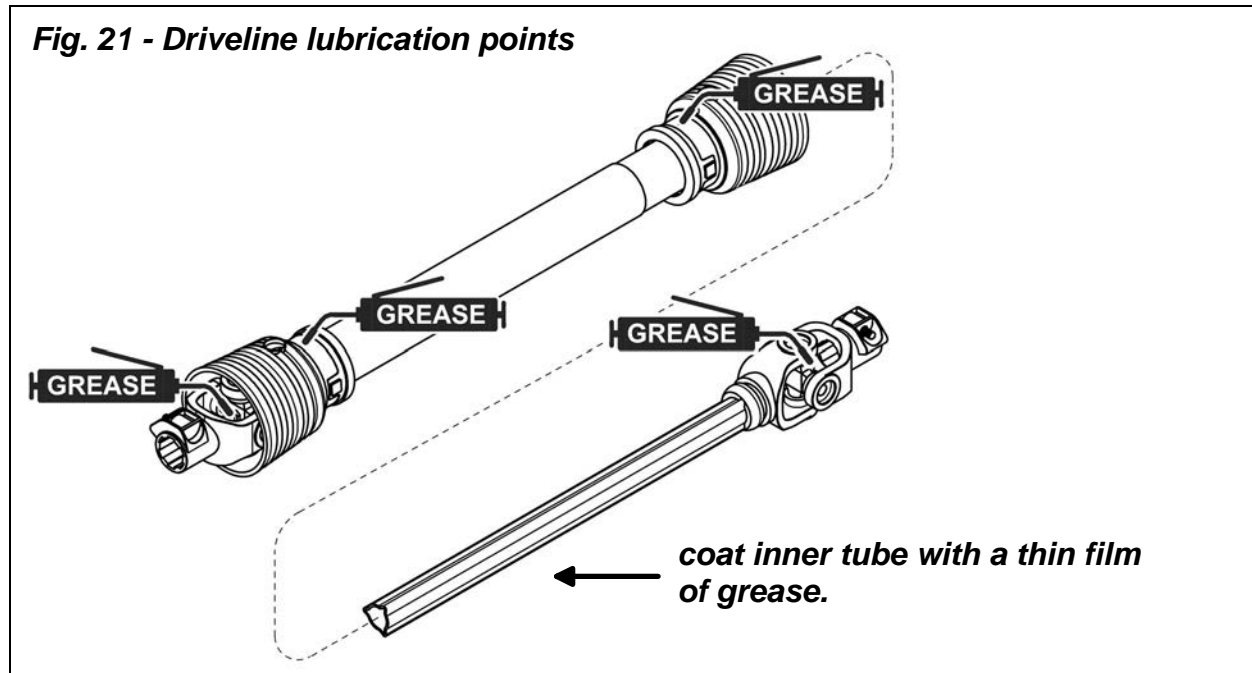

4.03 - Driveline



DANGER: Only use the original driveline supplied with this mower and always with the safety shielding. Carefully read and file away the driveline operator's manual supplied by the manufacturer. The following does not substitute the information found in the driveline manual.

IMPORTANT: Always check driveline length during initial setup and when connecting to a different tractor.

In the collapsed position the driveline should be approximately 2" from bottoming out to prevent possible damage to the tractor or implement. When the driveline is in the maximum possible extended position, the ideal minimum overlap of the two halves should be approximately 6" (see fig. 23).

If determined that the driveline is too long, follow these procedures to adjust the length:

1. Separate the two driveline halves. Connect one half to the tractor PTO and the other half to the mower.
2. Raise and lower the mower with the 3 point hitch to find the position where the driveline is shortest. Hold the half shafts side by side and mark the desired length on the outer female tube guard leaving a 1½" gap between the end of the guard tube and bell guard.
3. Cut off both guard tubes the same amount as marked in step 2.
4. Shorten both drive tubes the same amount as guard tubes.
5. De-burr and clean filings from drive tubes and apply grease to outside of inner telescoping tube.
6. Reassemble the driveline halves and connect to tractor and mower. Raise and lower mower again to be sure driveline does not bottom out in its shortest position and has a minimum overlap of 6" in the longest position.
7. Install both driveline safety chains. One should be hooked in a hole on the outer driveline yoke shield and to the tractor to restrict outer shield rotation. The second one should be hooked in a hole on the inner driveline yoke shield and to the implement to restrict inner shield rotation.





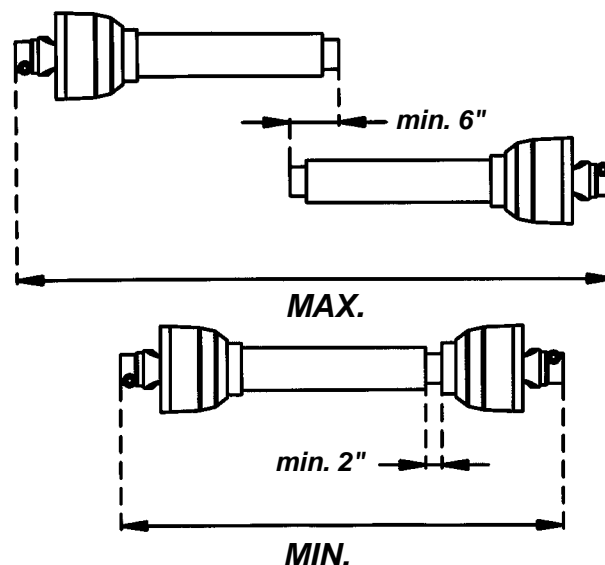

If determined that the driveline is too short for your tractor, contact your local dealer.

Fig. 23



CAUTION: Always work with the driveline as straight as possible. This will prolong its life and that of its components. It is advised not to work at an angle greater than 15 degrees.

TABLE 1 - TORQUE SPECIFICATIONS

Metric (ISO) treaded bolts head marking		 Class 5.8	 Class 8.8	 Class 10.9	Inch (SAE) treaded bolts head marking		 Grade 2	 Grade 5	 Grade 8						
Bolt size mm	Thread mm	N.m		ft-lb		N.m		ft-lb		N.m		ft-lb			
						Bolt size inch	Thread inch tpi								
M5	0.8	4	3	6	4	9	7	1/4"	20	7	5	11	8	16	12
M6	1	6	4	10	7	15	11	1/4"	28	8	6	13	10	19	14
M8	1.25	16	12	25	18	36	27	5/16"	18	15	11	24	17	33	25
M8	1	17	13	26	19	38	28	5/16"	24	17	13	26	19	37	27
M10	1.5	31	23	48	35	71	52	3/8"	16	27	20	42	31	59	44
M10	1.25	33	24	51	38	75	55	3/8"	24	31	23	47	35	67	49
M10	1	35	26	53	39	78	58	7/16"	14	43	32	67	49	95	70
M12	1.75	54	40	84	62	123	91	7/16"	20	48	36	75	55	106	78
M12	1.5	56	41	87	64	128	94	1/2"	13	66	48	102	75	144	106
M12	1.25	59	44	90	66	133	98	1/2"	20	75	55	115	85	163	120
M14	2	84	62	133	98	195	144	9/16"	12	95	70	147	109	208	154
M14	1.5	94	69	142	105	209	154	9/16"	18	106	79	164	121	232	171
M16	2	131	97	206	152	302	223	5/8"	11	132	97	203	150	287	212
M16	1.5	141	104	218	161	320	236	5/8"	18	149	110	230	170	325	240
M18	2.5	181	133	295	218	421	310	3/4"	10	233	172	361	266	509	376
M18	2	196	145	311	229	443	327	3/4"	16	261	192	403	297	569	420
M18	1.5	203	150	327	241	465	343	7/8"	9	226	167	582	430	822	606
M20	2.5	256	189	415	306	592	437	7/8"	14	249	184	642	473	906	668
M20	1.5	288	212	454	335	646	476	1"	8	339	250	873	644	1232	909
M22	2.5	344	254	567	418	807	595	1"	12	371	273	955	704	1348	995
M22	1.5	381	281	613	452	873	644	1-1/8"	7	480	354	1077	794	1746	1288
M24	3	444	327	714	526	1017	750	1-1/8"	12	539	397	1208	891	1958	1445
M24	2	488	360	769	567	1095	808	1-1/4"	7	677	500	1519	1120	2463	1817
M27	3	656	484	1050	774	1496	1103	1-1/4"	12	750	553	1682	1241	2728	2012
M27	2	719	530	1119	825	1594	1176	1-3/8"	6	888	655	1992	1469	3230	2382
M30	3.5	906	668	1420	1047	2033	1499	1-3/8"	12	1011	746	2268	1673	3677	2712
M30	2	1000	738	1600	1180	2250	1659	1-1/2"	6	1179	869	2643	1949	4286	3161
M36	4	1534	1131	2482	1830	3535	2607	1-1/2"	12	1326	978	2974	2194	4823	3557

When using lock washers with nuts, increase torque values by 5%.

TABLE 2 - SICKLE BAR MOWERS - TECHNICAL FEATURES

Series BSB sickle bar mowers, for tractors up to 75 HP.								
Model	HP	Working width	Weight lb.	Lift	Max. working speed	PTO (rpm)	3 point hitch	Driveline 1 3/8"
BSB-272	20-75	72"	628	Hydraulic	9 mph	540	Cat. 1	ASAE cat. 4
BSB-284	20-75	84"	650	Hydraulic	9 mph	540	Cat. 1	ASAE cat. 4
BSB-296	20-75	96"	672	Hydraulic	9 mph	540	Cat. 1	ASAE cat. 4

5 - REPAIR PROCEDURES



CAUTION: All repair procedures must be done by authorized dealerships. It is not recommended that untrained individuals perform any repair work.

5.01 - Blade Replacement

Replacement of blade section

Engage the float lock (see fig. 10) and lower the support stand on the sickle bar mower, using the tractors hydraulic system, lower the cutting bar so that it is laying flat on the ground then lower the implement so that it is resting on the support stand. Run the sickle bar mower for a few second to allow it to clean any debris between the blades and the teeth. This will facilitate blade section removal. Remove the two M8 bolts. Using the supplied blade section removal tool, unlock the spring loaded upper blade guides by turning the special screw (see fig. 25). Pull out the blade section from the outside of the cutting bar by inserting the supplied blade section removal tool (see fig. 24).

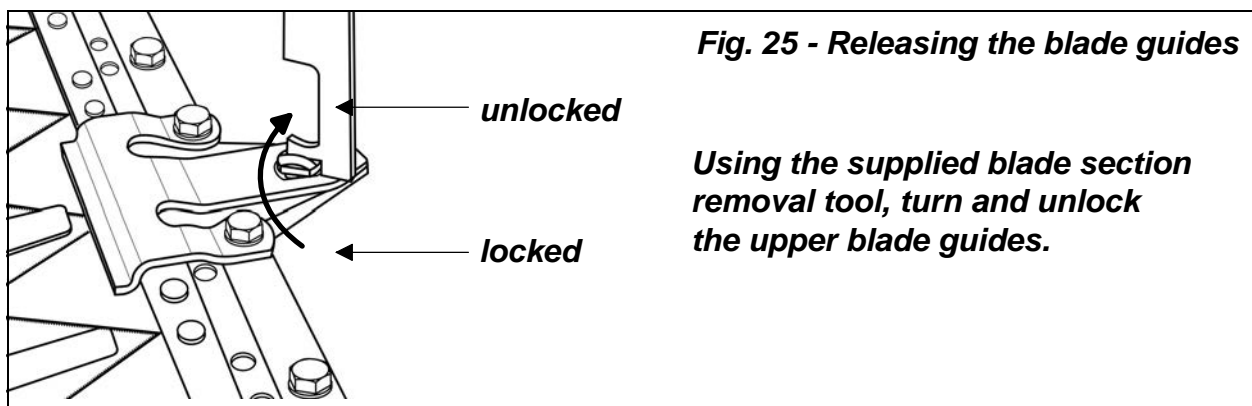
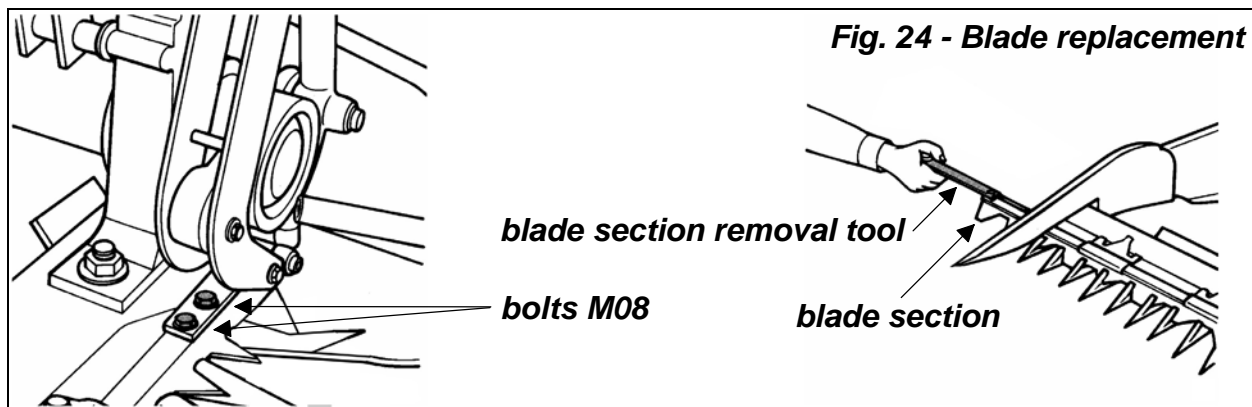

Reassemble the new blade section and secure it to the blade head using the two M8 bolts. Torque bolts to 20 ft-lb (27 N.m). Using the supplied tool, lock the spring loaded upper blade guides by turning the special screw (**see fig. 25**). If necessary, lubricate the blade section to facilitate removal and replacement operation.

It is important for the blade section and tooth bar to slide easily and with no obstructions inside the blade guides.

Replacement of individual blade

Engage the float lock (**see fig. 10**) and lower the support stand on the sickle bar mower. Using the tractors hydraulic system, lower the cutting bar so that it is laying flat on the ground. Lower the implement so that it is resting on the support stand. Run the sickle mower for a few seconds to allow it to clean any debris between the blades and the teeth. This will facilitate blade section removal. Remove the two M8 bolts that hold the blade section to the blade head (**see fig. 24**). Using the supplied tool, unlock the spring loaded upper blade guides by turning the special screw (**see fig. 25**). Pull out the blade section from the outside of the cutting bar by inserting the supplied blade section removal tool (**see fig. 24**).

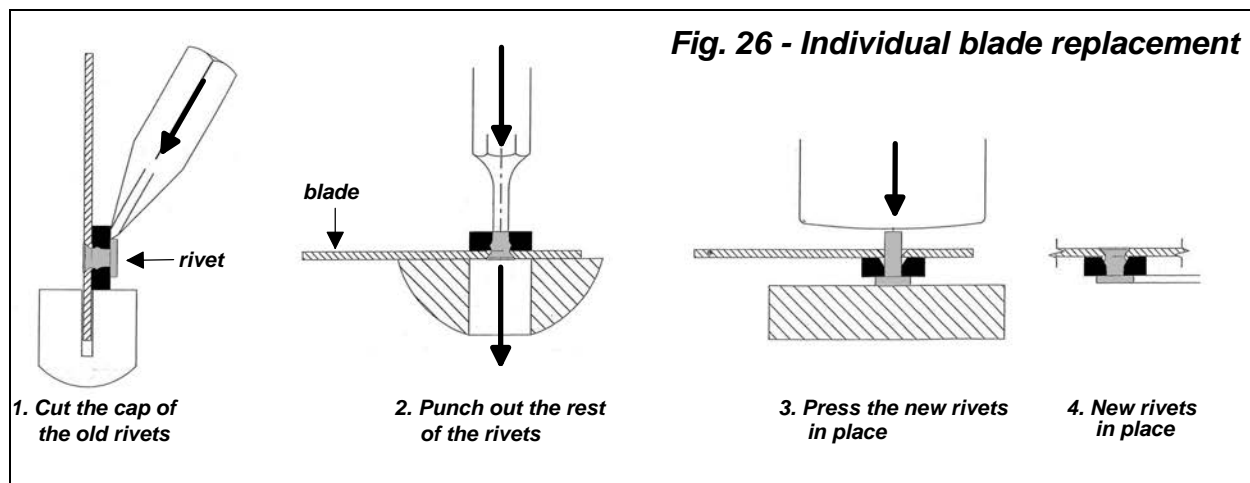

Break the cap of the old rivets off and remove the remainder of the rivets from the damaged/worn blade using a pin punch. Place new blade and rivets on blade section, turn the complete blade section upside down and press rivets in place making sure the bottom of the rivets is flush with the rest of the blade section (**see fig. 26**). Once the new blade is riveted on the blade section, reassemble the blade section and secure it to the blade head using the two M8 bolts. Torque bolts to 20 ft-lb (27 N.m). Using the supplied blade section removal tool, engage the spring loaded upper blade guides by turning the special screw (**see fig. 25**). If necessary, lubricate the blade section to facilitate removal and replacement operation.

It is important for the blade section and tooth bar to slide easily and with no obstructions inside the blade guides.

Replacement of tooth bar

Engage the float lock and lower the support stand on the sickle bar mower. Lower the cutting bar so that it is laying flat on the ground and then lower the implement so that it

is resting on the support stand. Remove all the bolts securing the tooth bar to the cutting bar. Remove the bushing using an M10 bolt to slide it out. (see fig. 27). Replace the new tooth bar and secure the head using the conical nut, the bushing, the cone, the spring washer and the M8x65 bolt.

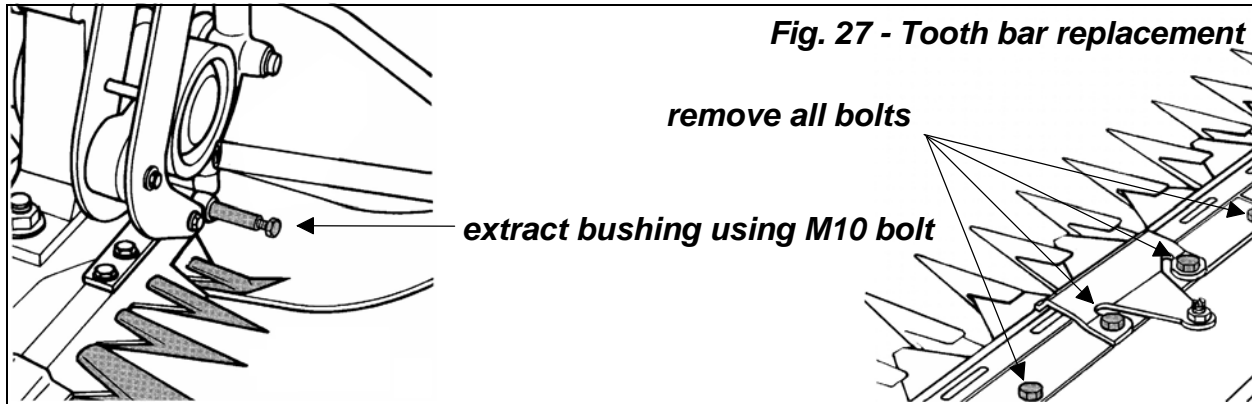

Replacement of individual tooth

With the implement resting on the ground and the cutting bar raised to 90°, secure the cutting bar in the transport position using the transport lock rod and wing nut. Remove the M8x12 flanged bolts of the tooth being replaced (see fig. 28). Replace individual tooth and secure it back to the cutting bar using the flanged bolts.

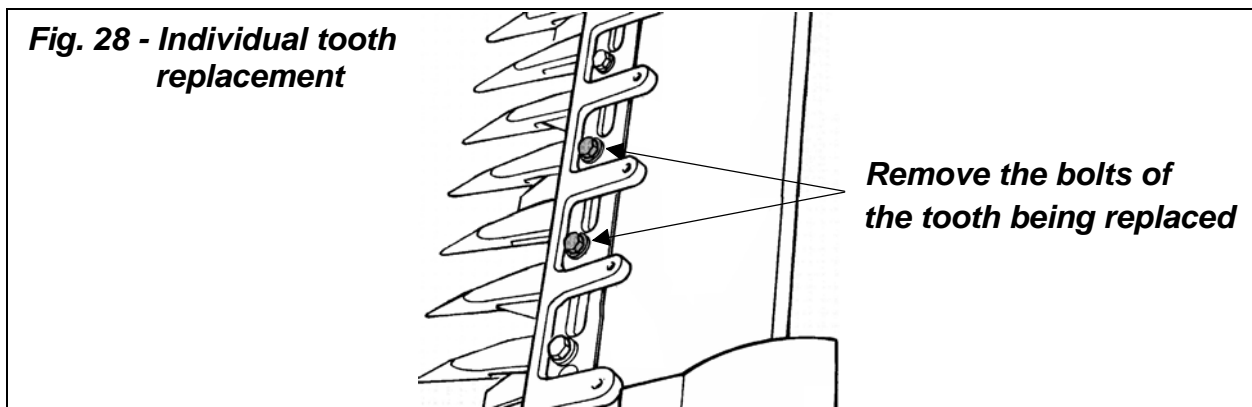

DANGER: Avoid injury from blade. Always replace blade guard on cutting bar when mower is not in use.

Replacement of belts

Loosen up completely the belt tensioner (see fig. 22). Remove the M10 locking nuts and spring washers then remove the outer belt shield. Remove the M12 nuts then remove the belt tensioner plate (see fig. 29). Remove the belts and replace with new ones. Replace the M12 nuts and the belt tensioner plate. Tighten the belt tensioner until arrow aligns with the washer (see fig. 22). Replace the outer belt shield and secure it using the M10 locking nuts and spring washers.

Replacement of pulleys

Loosen up completely the belt tensioner (see fig. 22). Remove the M10 locking nuts and spring washers then remove the outer belt shield. Remove the M12 nuts then remove the belt tensioner plate (see fig. 29). Remove the belts. To remove the drive pulley remove the M18 locking nut and the conical spring washer then replace the pulley with a new one and tighten using the M18 locking nut and conical spring washer. To remove the driven pulley turn pulley counterclockwise to unscrew it and replace it with a new one. Replace the belts. Replace the M12 nuts and the belt tensioner plate. Tighten the belt tensioner until arrow aligns with the washer (see fig. 22). Replace the outer belt shield and secure it using the M10 locking nuts and spring washers.

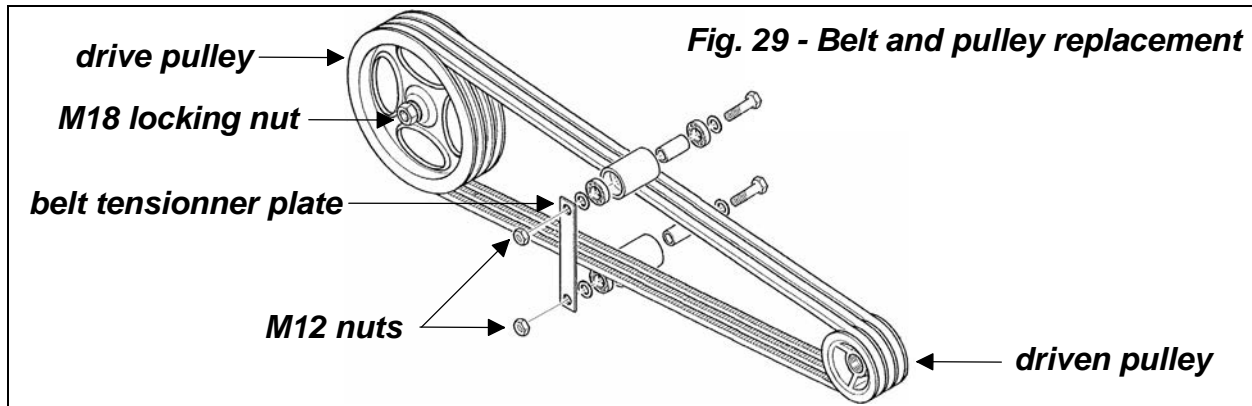

5.02 - Suggested Spare Parts

The BSB-272, 284 and 296 sickle bars are not only supplied with a complete spare blade section but also an assortment of spare parts. It is suggested that the following spare parts be kept on hand for the implement at all times to prevent a minor problem from delaying work.

Description	Quantity
Complete blade section	1
Individual blade	6
Rivets	12
Individual tooth	2
Bolt SP flange M08-1.00x12 C10.9	4
Spring washer Ø8	4
Spring washer Ø10	1
Locking pin Ø8x70	1
Grease fitting M10-1.50	2
Bolt CS M08-1.00x12 C10.9	1
Bolt SP CS M10-1.25x14 C10.9	1
Bolt HH M10-1.25x16 C8.8	1

5.03 - Storage

After seasonal use it is important to perform the following for prolonged storage:

1. When placing machine in storage, lower the support stand and secure it with the lock pin before lowering the unit to the ground.
2. Wash the implement carefully.
3. Inspect the implement and replace worn or damaged parts.
4. Replace blade guard on cutting bar.
5. Tighten all hardware.
6. Grease all areas indicated under Maintenance¹⁰.
7. Touch up scratches by sanding the area and applying a light coat of primer and paint to prevent rust from forming.
8. Cover the implement from the elements in order to have it in perfect condition for the start of the next season.
9. Make sure all parked machines are on a hard, level surface, and engage all safety devices.
10. Do not permit children to play on or around the stored unit.



WARNING: Be sure to store the implement on a hard level surface and away from people especially children.

Note: The machine demolition operations should be carried out in compliance with all federal, state and local environment protection laws.

¹⁰ See Chapter 4 - Maintenance.

6 - TROUBLESHOOTING



WARNING: Be sure tractor engine is off, parking brake is locked, and key is removed before making any adjustments.

PROBLEM	POSSIBLE CAUSE	SOLUTION
Mowed grass clumps up behind cutting bar.	Low mowing speed.	Increasing speed may help facilitate grass discharge. Try to mow between 6 to 9 mph if conditions allow it.
	Swath bar angle set too steep or grass too thick.	Open the swath bar to allow it to facilitate grass discharge.
Safety release latch splits without object being struck.	Cutting bar blades angled downwards.	Adjust turnbuckle to level cutting bar blade angle.

7 - PRE-DELIVERY CHECKLIST

To the dealer: Inspect the machine thoroughly after assembly to assure it is functioning properly before delivering it to the customer. The following checklist is a reminder of points to cover. Check off each item as it is found satisfactory or after proper adjustment is made.

- Guards and shield properly fastened.
- Lubrication of grease fittings.
- All hardware properly tightened.
- Belts are properly tightened.
- All decals properly located and readable (**see fig. 2**).
- Blade section and tooth bar properly installed.
- Overall condition (touch up scratches, clean and polish).
- Test run, check for excessive vibration or overheating of bearings.
- Operator's Manual.

Review the Operator's Manual with the customer. Explain the following:

- Warranty.
- Safe operation and service.
- Correct machine installation and operation.
- Daily and periodic lubrication, maintenance and inspections.
- Troubleshooting.
- Operational procedures and storage.
- Parts and service.
- Fill out the Pre-Delivery Checklist and Warranty Registration form.
- Give customer the Operator's Manual and encourage the customer to read the manual carefully.

IMPORTANT: Warranty is not valid unless Pre-Delivery Checklist and Warranty Registration Form in operator's manual is completed in detail and mailed to the Company.

Model Number: _____

Serial Number: _____

Delivery Date: _____

Dealer's Signature: _____

8 - WARRANTY

BEFCO's responsibility will be limited to substitution of the acknowledged defective merchandise to the same place of delivery as the previous one was supplied.

1. LIMITED WARRANTY

BEFCO, Inc. herein referred to as the Company, warrants its machines and related accessories, hereafter referred to as the Machine, to be free from defects in material and workmanship, for a period of twelve (12) months from the date of invoice to the first registered owner; this limited warranty does not apply to common wear items and excludes belts, shear pins, oil, grease, tires, tubes, hydraulic hoses, knives and PTO shafts.

Labor will be reimbursed at \$40.00 per hour based on BEFCO's time schedule.

Cost of transport to the servicing dealer is the responsibility of the customer.

Warranty coverage shall not be transferable from the first owner to any subsequent owner.

2. DISCLAIMER OF ALL OTHER WARRANTIES AND REMEDIES

Neither the Company nor any company affiliated with the Company makes any warranties, representations or promises, expressed or implied, as to the quality, performance or application of its products other than those set forth herein and does not make any implied warranty of merchantability or fitness.

The only remedies the purchaser has in connection with the breach, or performance of any warranty on the Company's Machine are those set forth herein. In no event will the dealer, the Company, or any company affiliated with the Company, be liable for:

- a. Injuries or damages of any kind or nature, direct, consequential or contingent to person or property.
- b. Any expenses incurred by the owner to repair, replace or rework any allegedly defective item.
- c. Any loss, cost, forfeiture or damages (including loss of profits; loss of crops; loss because of delay in field operations; any expenses or loss incurred for labor, supplies, substitute machine rental; liabilities of the owner to its customers or third persons; and all other consequential damages, losses, liabilities or damages for any other reasons) whether direct or indirect, and whether or not resulting from or contributed to by the default or negligence of the Company, its agents, employees and subcontractors which might be claimed as a result of the use or failure of the equipment delivered.

The Company's liability based on this limited warranty or any other applicable laws shall be limited to replacement or refund of the purchase price of the product.

The limited warranty extended herein gives you specific rights and you may also have other rights which vary from state to state. Neither the dealer nor the Company personnel has the authority to make any representation or to modify the terms and limitations of this warranty in any way.

Other than the limited warranty extended hereby there is no other expressed warranty in connection with the design, safety or use of any of the Company's products except as to title. All implied warranties are expressly disclaimed pursuant to the terms of this warranty.

3. CUSTOM WORK

If the Machine is used for commercial purposes such as custom work, the period warranted for the Machine is limited to six (6) months from the date of delivery to the first registered owner and does not cover any labor charges incurred.

4. RENTAL

If the Machine is used for rental purposes the period warranted for the Machine is limited to thirty (30) days from the date of delivery to the first registered owner and does not cover any labor charges incurred.

5. REGISTRATION

In order to qualify for coverage on this limited warranty, the product and name of the original purchaser must be registered with the Company by a completed Machine Pre-Delivery Checklist and Warranty Registration along with a copy of the dealer's invoice to the first registered owner to the Company within fourteen (14) days after the date of delivery to the original purchaser.

6. WARRANTY SERVICE

Warranty Service must be performed by a dealer authorized by BEFCO. If the warranty service requested is approved, the owner shall pay only for labor beyond the rate allowed, for overtime labor, and for any mileage charge for transporting the equipment to and from the dealer's shop. It is assumed that the dealer has the appropriate general and special tools to service the machine. Time required for replacement of knives, oil, grease and to remove excessive dirt from the Machine is not subject to reimbursement by the Company. The owner is required to clean the Machine before presenting it to the dealer for service work. The Machine must be delivered within thirty (30) days after failure date by the owner to the dealer to be eligible for warranty consideration.

7. UNAPPROVED SERVICE OR MODIFICATION

All obligations of the Company under this limited warranty shall be terminated if:

- a. Proper service and operation instructions as outlined in the Operator's Manual and on the instruction sticker on the Machine, are not followed.
- b. The Machine is modified or altered in any way not approved by the Company.
- c. The Company does not receive a copy of the dealer's invoice to the first registered owner within fourteen (14) days from the date of delivery.
- d. The Company has not been paid in full, by the dealer, for the Machine.

8. ACCIDENTS AND NORMAL MAINTENANCE

This limited warranty covers defective material and workmanship. It does not cover depreciation or damage caused by normal wear, accidents, improper maintenance, improper protection or improper use. The costs of normal maintenance or repairs for accidents or improper use, and related labor will be borne by the owner.

9. REPLACEMENT PARTS

BEFCO, Inc. warrants replacement parts to be free from defect in material and workmanship for a period of thirty (30) days from the date of delivery to the original purchaser.

WARRANTY REGISTRATION

BEFCO, Inc.
P.O. Box 6036
Rocky Mount, NC 27802-6036

Tel: (252) 977.9920 - Fax: (252) 977.9718

Dealer _____ Acct. # _____	Retail Customer _____
Street _____ Country _____	Street _____
Town _____ State _____ Zip _____	Town _____ State _____ Zip _____
Date of delivery _____ Invoice # _____	Phone _____
Model # _____ Serial # _____	
<p>Pre-Delivery Checklist:</p> <p><input type="checkbox"/> Greased fittings.</p> <p><input type="checkbox"/> Safety guards in place.</p> <p><input type="checkbox"/> All hardware tight.</p> <p><input type="checkbox"/> Bolts torqued correctly.</p> <p><input type="checkbox"/> Attached unit to tractor. Yes/No.</p> <p><input type="checkbox"/> Field adjusted. Yes/No.</p> <p><input type="checkbox"/> Test run. Dry/Infield.</p> <p><input type="checkbox"/> Safety decals.</p> <p><input type="checkbox"/> Operator's Manual.</p> <p>The machine described above has been prepared for delivery according to the Pre-Delivery Checklist and the Customer has been instructed in its care and operation and the condition of warranty.</p>	<p>Tractor make: _____</p> <p>Model: _____; HP _____</p> <p>Type of operation: Private homeowner, Landscaping, Commercial maintenance, Golf Course, Municipality, Turf Farm, others: _____</p> <p>Approximate number of acres machine will be used on annually: _____</p> <p>I hereby acknowledge that: I have received and accepted delivery of the machine described. The equipment was checked thoroughly for loose or missing parts and has been adjusted in accordance with the Pre-Delivery Checklist. I have read and understand the nature and extent of the warranty and understand clearly that there were and are no other representations of warranties either expressed or implied, made by anyone. I have been advised on proper operation, maintenance and lubrication procedure of this equipment. I have been instructed on and do understand the application, limitation and capacities this equipment was designed and recommended for, all as described in the Operator's Manual and literature published by the Company.</p>
Inspected by: _____	
Date: _____	Date: _____
Dealer's Signature: _____	Customer's Signature: _____

This registration along with a copy of the invoice must be sent to BEFCO, Inc. within 14 days of date of purchase.

Sender:

Fold here

*Place stamp
here*

BEFCO, Inc.

Warranty Department

P.O. Box 6036

Rocky Mount, NC 27802-6036

Cut along this line

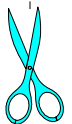

BEFCO®

Parts Manual

SICKLE BAR MOWERS

BSB-272, BSB-284, BSB-296

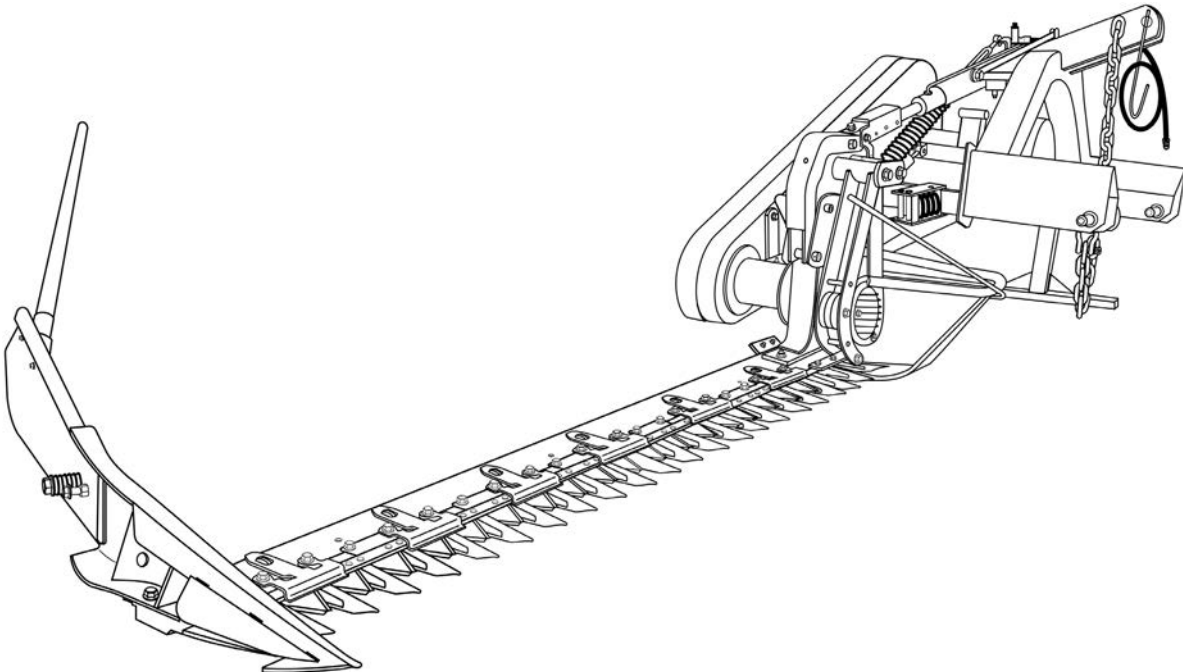

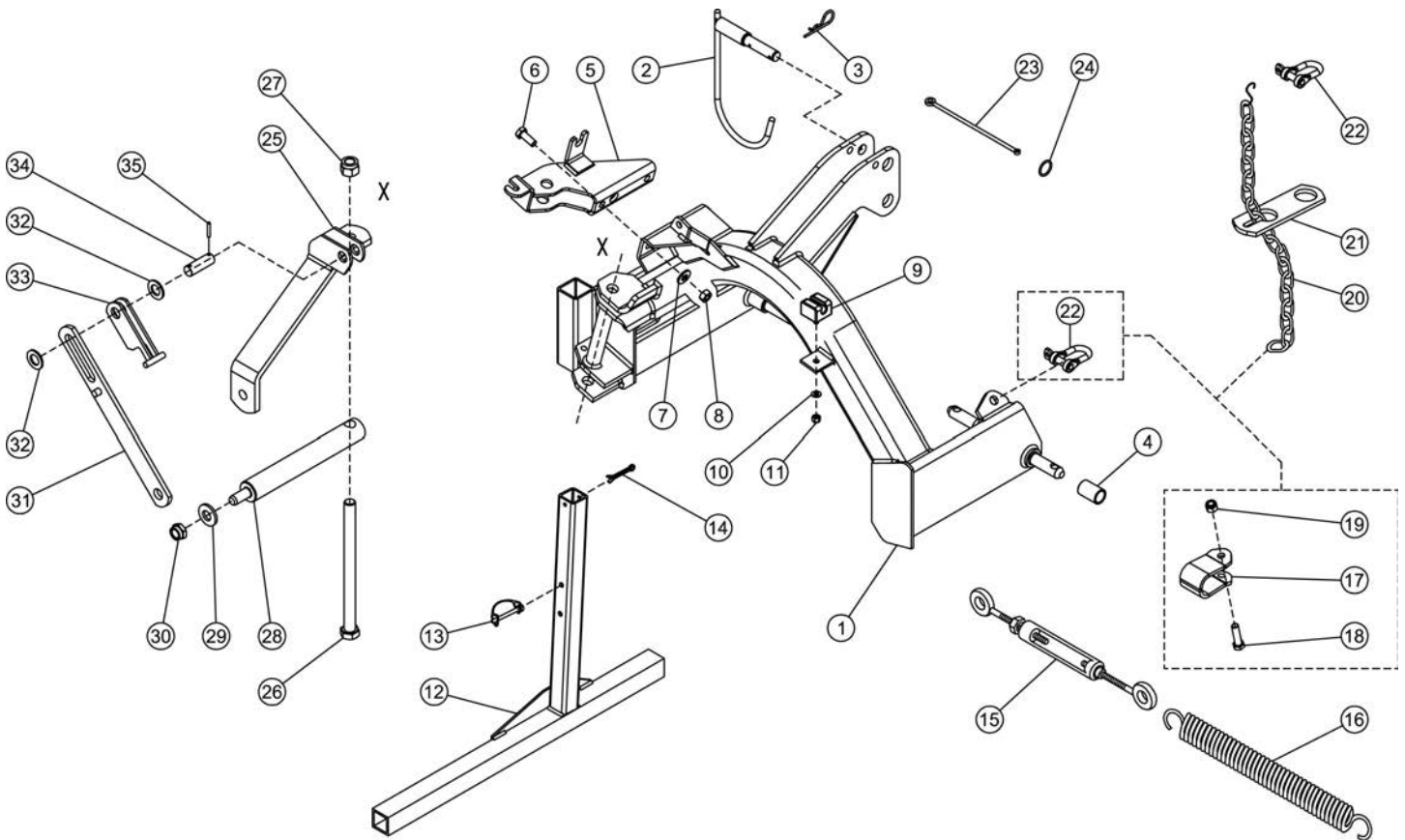

Ref.	Part #	Description	Qty.
1	59028980AS	Three point hitch	1
2	59028818ZS	Pin, top hitch	1
3	009-1507	Hairpin cotter Ø4 Z	1
4	56336449ZS	Bushing cat.1-2	2
5	59028766NS	Connection	1
6	000-7255	Bolt HH M12-1.75x35 C8.8 Z F	2
7	31421130S	Washer conical spring Ø12 Z	2
8	000-1106	Nut HH M12-1.75 C6 Z MD	2
9	58047438S	Stopper	1
10	001-5230	Washer flat Ø08 Z	1
11	009-1384	Nut ES M08-1.25 Z TK	1
12	59028890NS	Support stand	1
13	34230008S	Lynch pin Ø8x70	1
14	34110061S	Cotter pin Ø6x50	1
15	58027944S	Tensioner M14	1
16	58028772NS	Spring	1
17	56128831ZS	Clamp; #317910 & below	1
18	002-3265	Bolt HH M12-1.75x40 C8.8 Z F; #317910 & below	1
19	001-3345	Nut ES M12-1.75 Z TK; #317910 & below	1
20	58027235S	Chain	1
21	56127395NS	Plate, tractor coupling	1
22	30000031S	Bolt "U" M12-1.75	2
23	58028125S	Rubber cable	1
24	58027985S	Ring	1
25	59028813NS	Top link	1
26	31112520S	Bolt HH M20-2.50x280 C8.8 Z P	1
27	009-2276	Nut ES M20-2.50 Z TN	1
28	56128812S	Shaft	1
29	000-8560	Washer conical spring Ø18 Z	1
30	000-6643	Nut SP M18-1.50 Z	1
31	59028815NS	Complete rod	1
32	004-6555	Washer flat Ø20 Z	2
33	59028856YS	Float lock	1
34	56332234S	Pin	1
35	501-596B	Roll pin Ø5x40	2
	59027155ZS	Blade removal tool (not shown)	1
	59030421S	Grease gun (not shown)	1

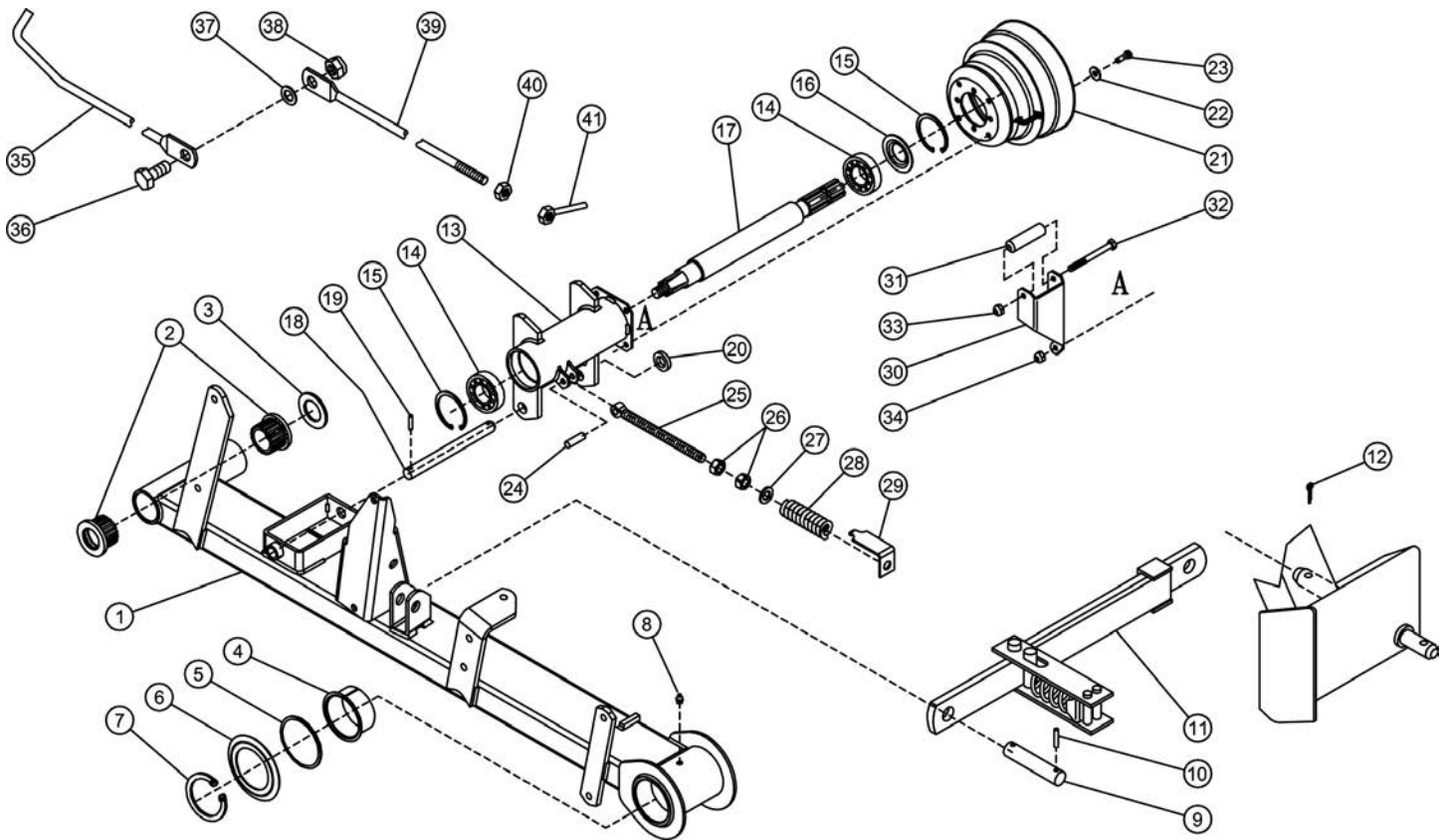

Ref.	Part #	Description	Qty.
1	59028800NS	Lifting arm	1
2	58027501S	Sleeve	2
3	56127505ZS	Washer SP Ø40	1
4	57127397S	Sleeve	2
5	003-6703	Oil ring 3250	1
6	56128836ZS	Cup	1
7	35121080S	Snap ring, outer Ø80	1
8	503-500B	Grease fitting M10-1.50 STR	1
9	56332234S	Pin	1
10	501-596B	Roll pin Ø5x40	2
11	59027935NS	Safety release latch	1
12	34110061S	Cotter pin Ø6x50	1
13	59028650NS	Support, shaft	1
14	503-197B	Bearing 6207-2RS	2
15	002-5329	Snap ring, inner Ø72	2
16	56131476ZS	Shaft flange	1
17	56328658S	Control shaft	1
18	56328798ZS	Pin	1
19	000-6605	Roll pin Ø6x32	2
20	56128797ZS	Spacer, shaft support	1
21	000-8663	Guard, shaft	1
22	001-4514	Washer fender Ø08 Z	4
23	009-1446	Bolt HH M08-1.25x25 C8.8 Z F	4
24	000-5521	Roll pin Ø10x45	1
25	58027391ZS	Top link	1
26	000-3124	Nut HH M16-2.00 C6 Z MD	2
27	58128661YS	Washer flat Ø16 Y	1
28	58031458NS	Spring	1
29	56131457YS	Indicator	1
30	56128833NS	Support, nylon roller	1
31	58028834S	Roller, nylon	1
32	001-5236	Bolt HH M10-1.50x80 C8.8 Z P	1
33	001-4106	Nut ES M10-1.50 Z TK	1
34	009-1384	Nut ES M08-1.25 Z TK	4
35	56128825NS	Rod	1
36	000-7255	Bolt HH M12-1.75x35 C8.8 Z F	1
37	000-2265	Washer flat Ø12 Z	1
38	001-3345	Nut ES M12-1.75 Z TK	1
39	56128829NS	Rod, transport lock	1
40	001-7188	Nut HH M16-2.00 C6 Z TN	1
41	59029728ZS	Nut wing SP M16-2.00	1

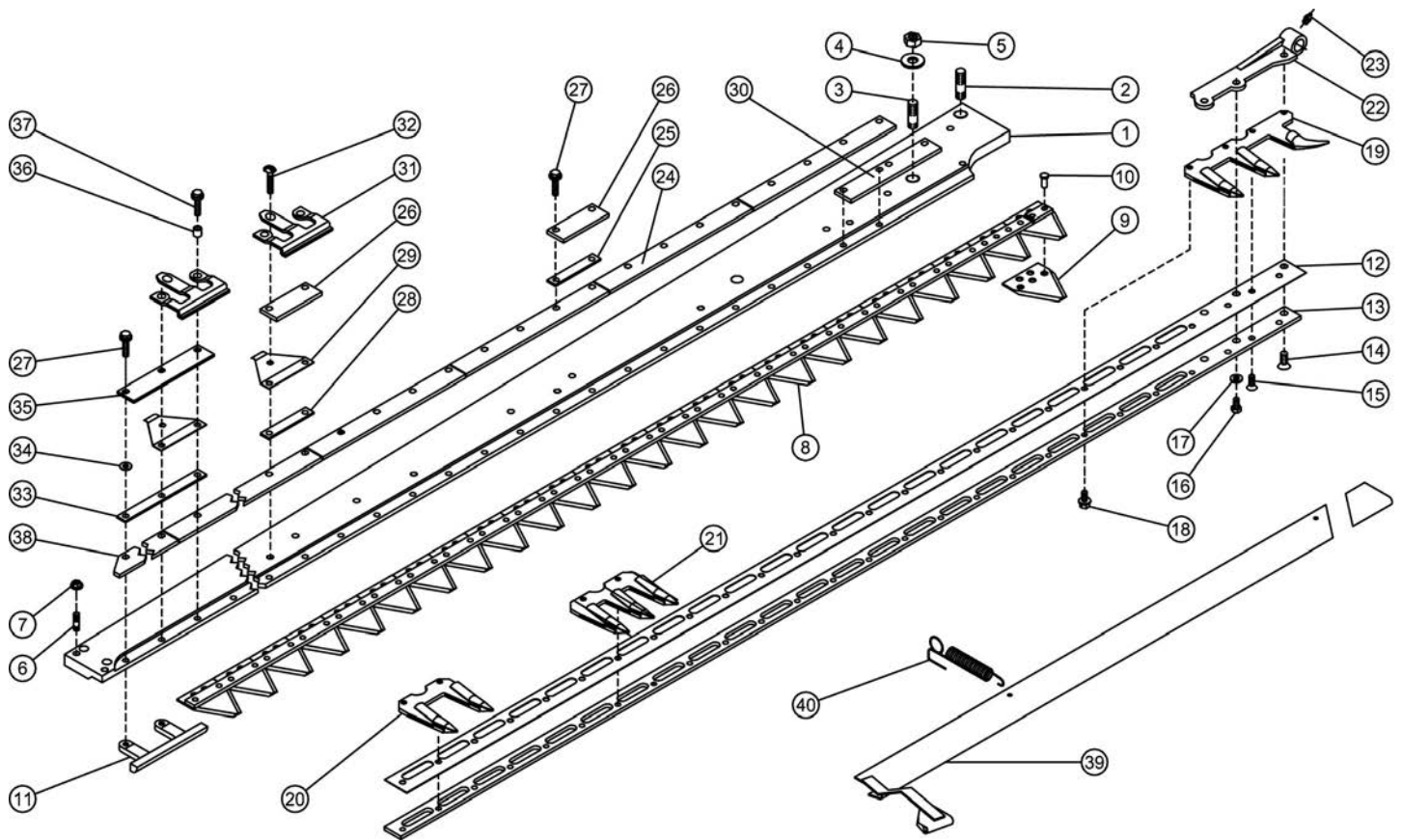

Ref.	Part #	Description	Qty.
1	56328908NS	Bar 72"; BSB-272	1
	56328909NS	Bar 84"; BSB-284	1
	56328898NS	Bar 96"; BSB-296	1
2	58028070S	Bolt stud M20-1.50x56 10K ¹¹	1
3	58027318S	Bolt stud M20-1.50x62 10K ¹²	1
4	31421060S	Washer conical spring Ø20 Z	2
5	000-5542	Nut HH M20-1.50 C6 Z MD ¹³	2
6	31312100S	Bolt stud M10-1.50x40x20x16 8G	2
7	31241104S	Nut PT flange M10-1.50 Z TK	2
8	58028910TS	Blade section 72", complete; BSB-272	1
	58028912TS	Blade section 84", complete; BSB-284	1
	58028914TS	Blade section 96", complete; BSB-296	1
9	58028096S	Blade section; BSB-272	24
	58028096S	Blade section; BSB-284	28
	58028096S	Blade section; BSB-296	32
10	33125314S	Rivet, flat head 5.3x14; BSB-272	48
	33125314S	Rivet, flat head 5.3x14; BSB-284	56
	33125314S	Rivet, flat head 5.3x14; BSB-296	64
11	52158589S	Lower guide; BSB-272	11
	52158589S	Lower guide; BSB-284	13
	52158589S	Lower guide; BSB-296	15
12	56328732S	Wear plate 72"; BSB-272	1
	56328733S	Wear plate 84"; BSB-284	1
	56328734S	Wear plate 96"; BSB-296	1
13	56328701S	Tooth rod 72"; BSB-272	1
	56328703S	Tooth rod 84"; BSB-284	1
	56328704S	Tooth rod 96"; BSB-296	1
14	58028198S	Bolt SP CS M10-1.25x14 C10.9 Z F ¹⁴	1
15	31134060S	Bolt CS M08-1.00x12 C10.9 Z F ¹⁵	2
16	31113098S	Bolt HH M10-1.25x16 C10.9 Z F ¹⁶	2
17	001-9222	Washer conical spring Ø10 Z	2
18	58058659S	Bolt SP flange M08-1.00x12 C10.9; BSB-272 ¹⁷	24
	58058659S	Bolt SP flange M08-1.00x12 C10.9; BSB-284 ¹⁸	28
	58058659S	Bolt SP flange M08-1.00x12 C10.9; BSB-296 ¹⁹	32
19	59028934TS	First tooth (3" tooth spacing)	1
20	59028930TS	Last tooth (3" tooth spacing)	1
21	59028932TS	Tooth (2" tooth spacing); BSB-272	10
	59028932TS	Tooth (2" tooth spacing); BSB-284	12
	59028932TS	Tooth (2" tooth spacing); BSB-296	14

¹¹ Torque to 67 ft-lb (90 N.m).¹² Torque to 67 ft-lb (90 N.m).¹³ Torque to 130 ft-lb (176 N.m).¹⁴ Torque to 51 ft-lb (69 N.m).¹⁵ Torque to 29 ft-lb (39 N.m).¹⁶ Torque to 51 ft-lb (69 N.m).¹⁷ Torque to 29 ft-lb (39 N.m).¹⁸ Torque to 29 ft-lb (39 N.m).¹⁹ Torque to 29 ft-lb (39 N.m).

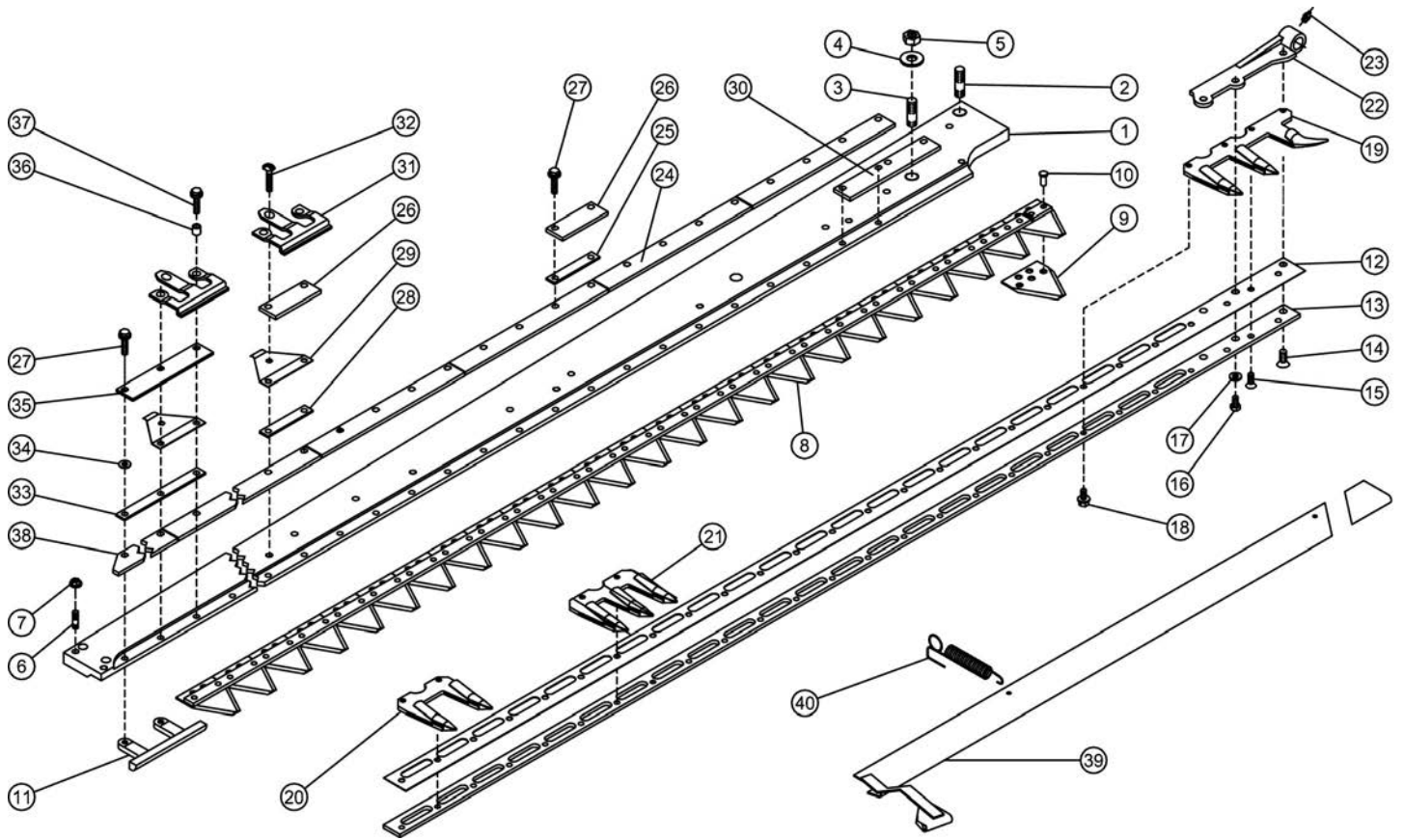

Ref.	Part #	Description	Qty.
22	52428706S	Teeth head	1
23	306-002F	Grease fitting M08-1.25 STR Z	1
24	56327169TS	Blade guide, lower; BSB-272	5
	56327169TS	Blade guide, lower; BSB-284	6
	56327169TS	Blade guide, lower; BSB-296	7
25	56128716NS	Shim (3 mm.); BSB-272	4
	56128716NS	Shim (3 mm.); BSB-284	5
	56128716NS	Shim (3 mm.); BSB-296	6
26	56327723TS	Blade guide, upper; BSB-272	7
	56327723TS	Blade guide, upper; BSB-284	9
	56327723TS	Blade guide, upper; BSB-296	11
27	31112167S	Bolt HH flange M08-1.25x30 Z P; BSB-272	10
	31112167S	Bolt HH flange M08-1.25x30 Z P; BSB-284	12
	31112167S	Bolt HH flange M08-1.25x30 Z P; BSB-296	14
28	56127724ZS	Shim (2.5 mm.); BSB-272	4
	56127724ZS	Shim (2.5 mm.); BSB-284	5
	56127724ZS	Shim (2.5 mm.); BSB-296	6
29	56328757TS	Leaf spring; BSB-272	6
	56328757TS	Leaf spring; BSB-284	7
	56328757TS	Leaf spring; BSB-296	8
30	56328972TS	Upper blade guide, left	1
31	56528756ZS	Blank holder; BSB-272	6
	56528756ZS	Blank holder; BSB-284	7
	56528756ZS	Blank holder; BSB-296	8
32	58028760S	Screw SP; BSB-272	6
	58028760S	Screw SP; BSB-284	7
	58028760S	Screw SP; BSB-296	8
33	56127173ZS	Shim (2.5 mm.), right	2
34	31423084S	Washer wave spring Ø8 Z	2
35	56328715TS	Upper blade guide, right	2
36	56428758S	Sliding bushing; BSB-272	12
	56428758S	Sliding bushing; BSB-284	14
	56428758S	Sliding bushing; BSB-296	16
37	31112165S	Bolt HH flange M08-1.25x35 Z P; BSB-272	12
	31112165S	Bolt HH flange M08-1.25x35 Z P; BSB-284	14
	31112165S	Bolt HH flange M08-1.25x35 Z P; BSB-296	16
38	56328713TS	Lower blade guide, right	1
39	59028146RS	Blade guard 72"; BSB-272	1
	59028147RS	Blade guard 84"; BSB-284	1
	59028510RS	Blade guard 96"; BSB-296	1
40	58027286RS	Spring	2

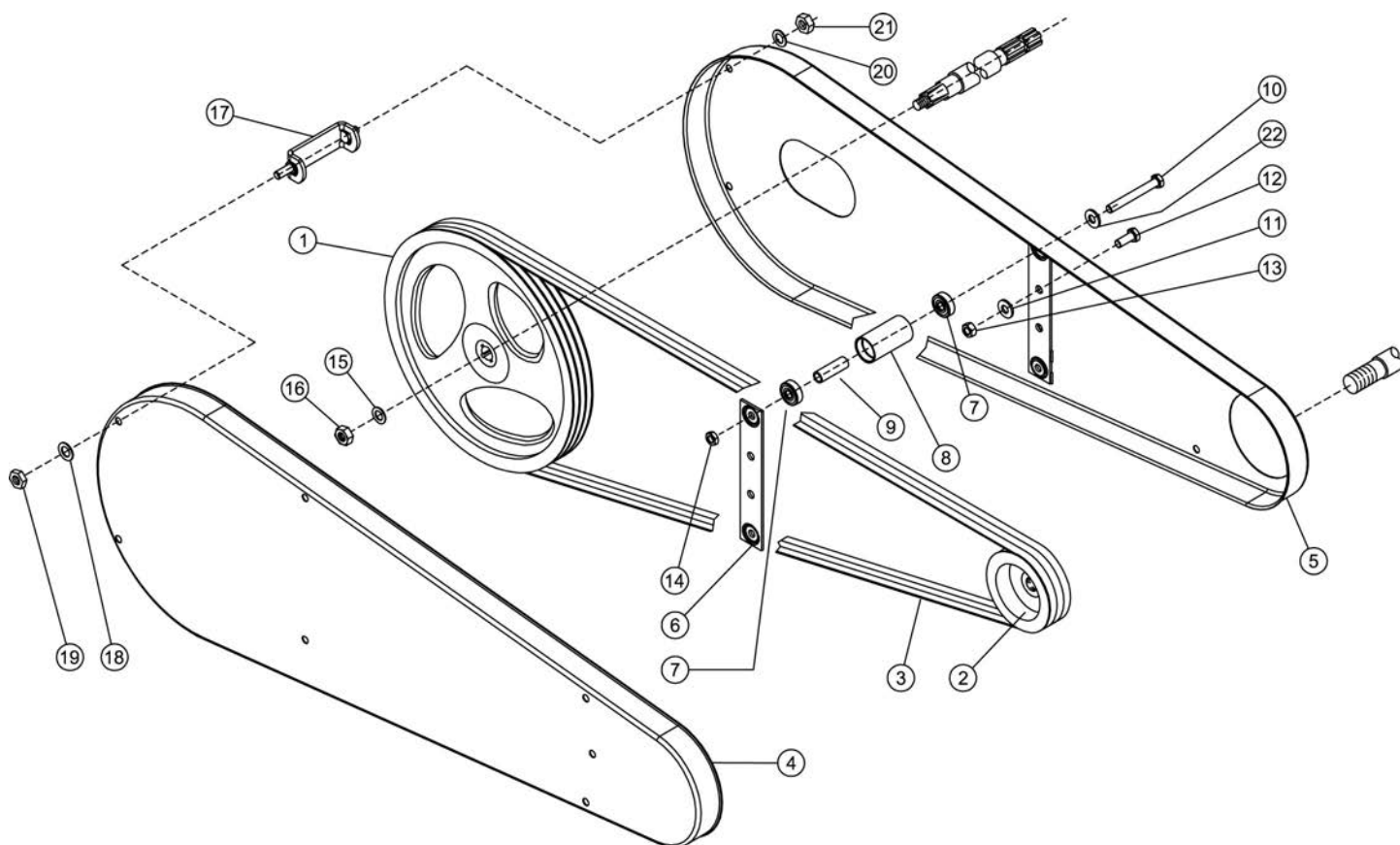

Ref.	Part #	Description	Qty.
1	53227939S	Pulley B366	1
2	56127940S	Pulley B130 ²⁰	1
3	36220021S	Belt B102	3
4	56128851AS	Belt shield, outer	1
5	59028849AS	Belt shield, inner	1
6	56128853NS	Plate, belt tensioner	1
7	37112105S	Bearing 6301-2RS	4
8	56127277NS	Roller	2
9	56127278S	Spacer	2
10	003-4286	Bolt HH M12-1.75x100 C8.8 Z P	2
11	31421130S	Washer conical spring Ø12 Z	2
12	000-7255	Bolt HH M12-1.75x35 C8.8 Z F	2
13	000-1106	Nut HH M12-1.75 C6 Z MD	2
14	001-7223	Nut HH M12-1.75 C6 Z TN	2
15	000-8560	Washer conical spring Ø18 Z	1
16	000-6643	Nut SP M18-1.50 Z ²¹	1
17	59028852ZS	Bracket, belt shield	6
18	31423105S	Washer wave spring Ø10 Z	6
19	001-4106	Nut ES M10-1.50 Z TK	6
20	001-9222	Washer conical spring Ø10 Z	6
21	009-0150	Nut HH M10-1.50 C6 Z MD	6
22	000-2265	Washer flat Ø12 Z	2

²⁰ Torque to 188 ft-lb (255 N.m).

²¹ Torque to 159 ft-lb (216 N.m).

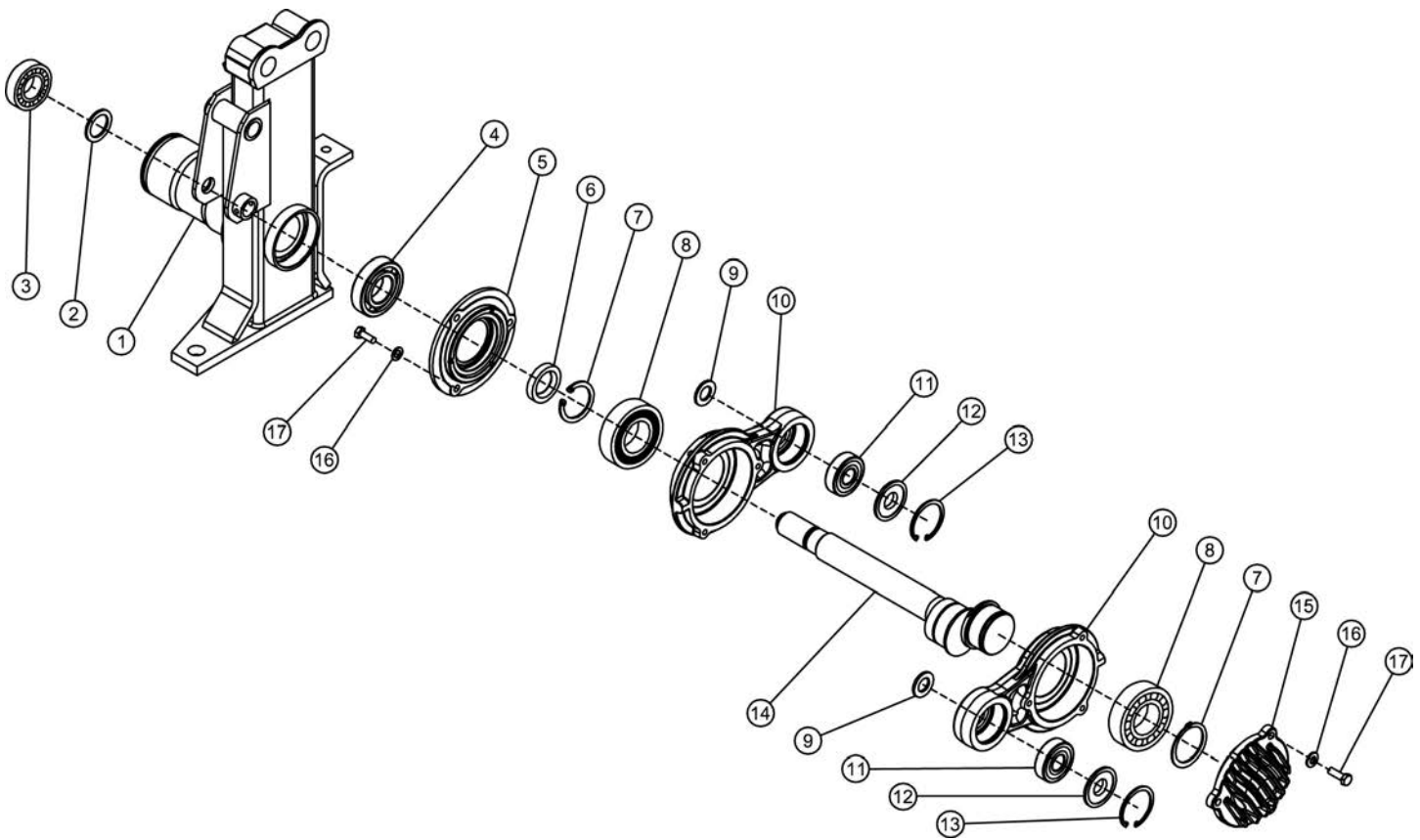

Ref.	Part #	Description	Qty.
1	59028862NS	Support	1
2	58128867S	Shim Ø30	1
3	005-0212A	Bearing 6306-2RS	1
4	503-197B	Bearing 6207-2RS	1
5	53127149S	Cover	1
6	38215502S	Oil seal 55.70.8	1
7	501-941B	Snap ring, outer Ø55	2
8	37112550S	Bearing 6211-2RS C3	2
9	38203010S	Oil seal 20.28.4	2
10	53028971S	Connecting rod	2
11	37112204S	Bearing 6304-2RS	2
12	58027164S	Dust cap	2
13	35111052S	Snap ring, inner Ø52	2
14	52428866S	Control shaft	1
15	53127174S	Cover, connecting rod	1
16	001-9451	Washer conical spring Ø8 Z	6
17	009-1446	Bolt HH M08-1.25x25 C8.8 Z F	6

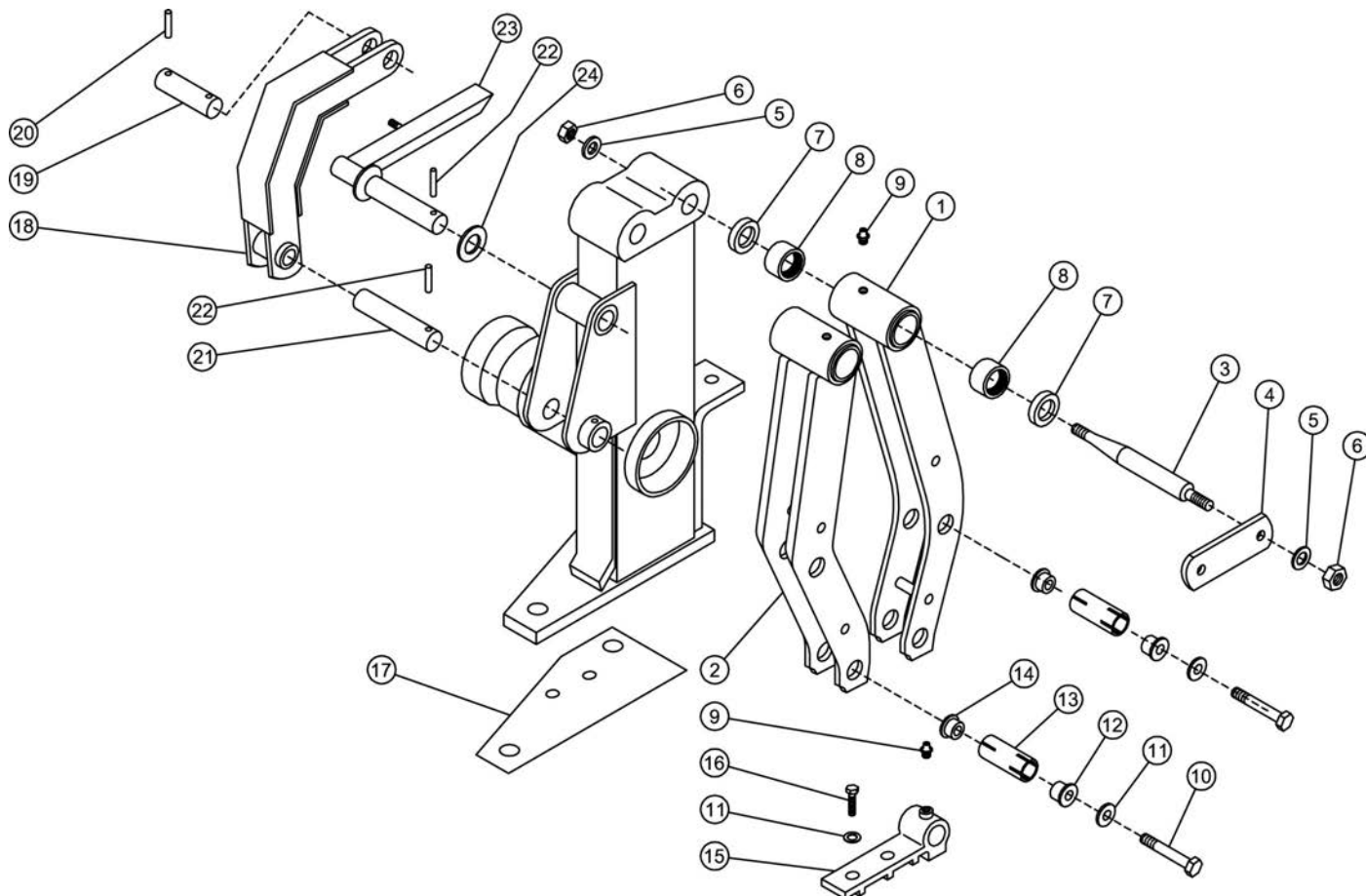

Ref.	Part #	Description	Qty.
1	59027900NS	Arm, tooth bar	1
2	59027873NS	Arm, blade bar	1
3	56427878S	Pin	2
4	56127236NS	Fixing plate	1
5	31421130S	Washer conical spring Ø12	4
6	31211123S	Nut HH M12-1.25 C6 Z MD	4
7	58027230S	Dust seal SP	4
8	37331256S	Bushing	4
9	306-002F	Grease fitting M08-1.25 STR Z	3
10	009-1208	Bolt HH M08-1.25x65 C8.8 Z P	4
11	001-9451	Washer conical spring Ø8 Z	6
12	56327227ZS	Cone	4
13	56427225S	Bushing	4
14	56327226XS	Nut conic SP Ø17 M08-1.25	4
15	52428729S	Blade head	1
16	004-6454	Bolt HH M08-1.25x16 C8.8 Z F	2
17	56128165S	Shim (0.5 mm.)	4
18	59028870NS	Lever	1
19	56332234S	Pin	1
20	501-596B	Roll pin Ø5x40	2
21	56328869ZS	Pin	1
22	000-6605	Roll pin Ø6x32	2
23	59028876NS	Stop bar	1
24	004-6555	Washer flat Ø20 Z	1

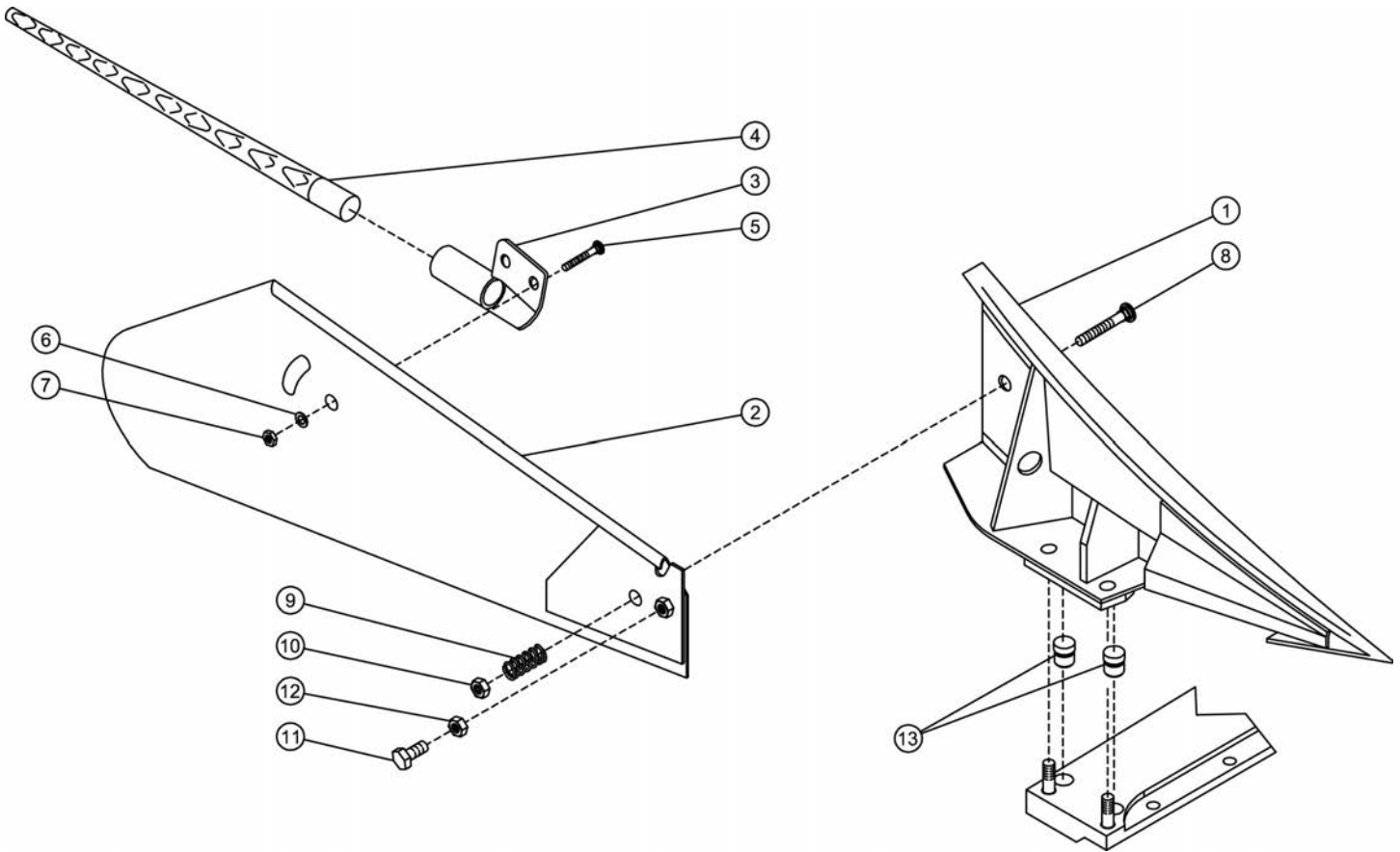

Ref.	Part #	Description	Qty.
1	59028927NS	Support, outer bar	1
2	59028925NS	Swath board, complete	1
3	59027298NS	Stick holder	1
4	58002463S	Deflector stick	1
5	008-4289	Bolt CR M08-1.25x20 C4.6 Z	2
6	001-5230	Washer flat Ø08 Z	2
7	009-1384	Nut ES M08-1.25 Z TK	2
8	005-7375	Bolt CR M12-1.75x80 C4.6 Z	1
9	58002430NS	Spring	1
10	31241123S	Nut ES flange M12-1.75 Z TK	1
11	002-3265	Bolt HH M12-1.75x40 C8.8 Z F	1
12	000-1106	Nut HH M12-1.75 C6 Z MD	1
13	56328923S	Pin	2

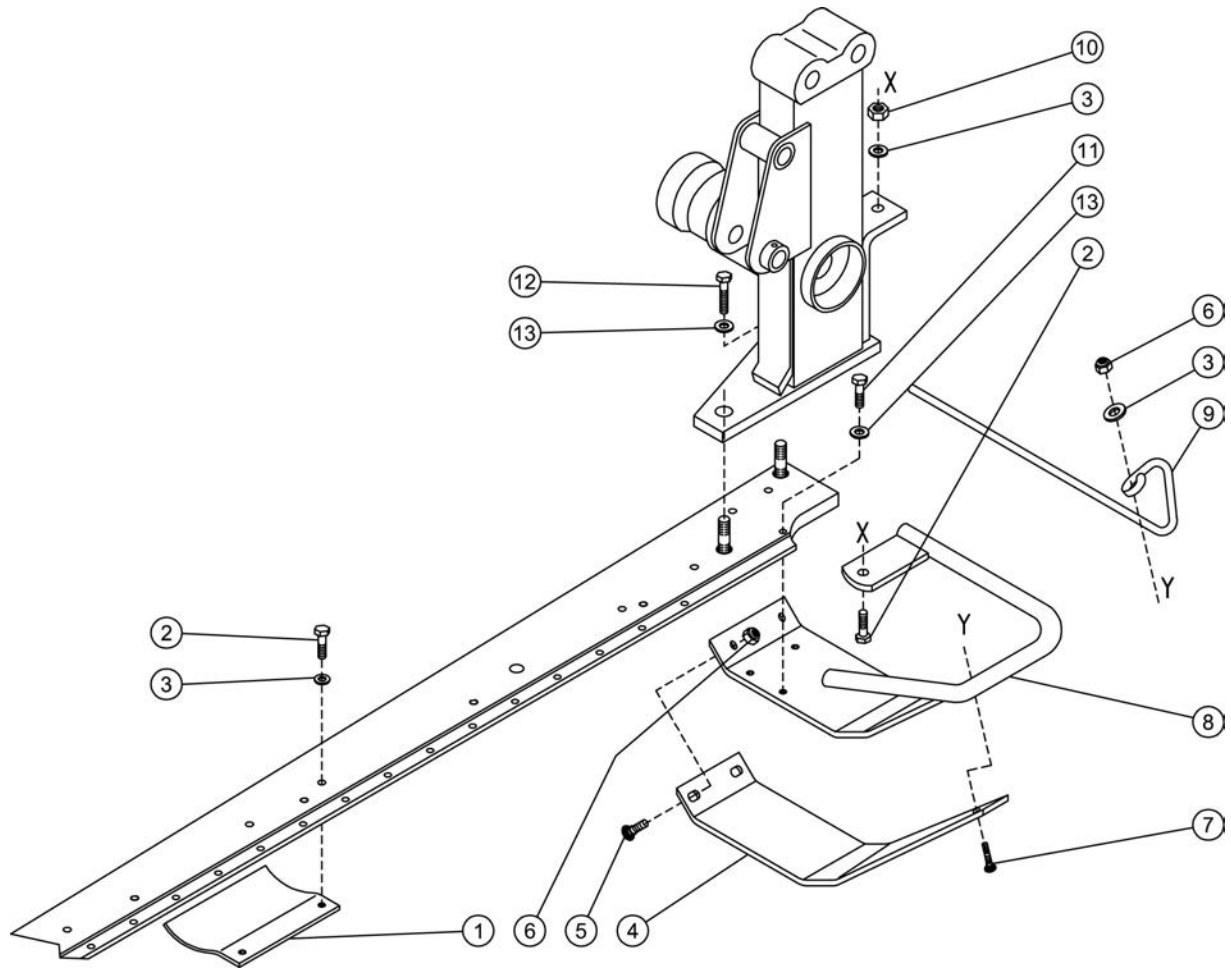

Ref.	Part #	Description	Qty.
1	56127255NS	Skid	3
2	000-1278	Bolt HH M10-1.50x30 C8.8 Z F	7
3	001-9222	Washer conical spring Ø10 Z	8
4	56128255NS	Internal skid	1
5	006-0509	Bolt CR M10-1.50x25 C8.8 Z	2
6	001-4106	Nut ES M10-1.50 Z TK	3
7	31121603S	Bolt CR M10-1.50x40 C4.8 Z	1
8	59028745NS	Guard, lower	1
9	58028748NS	Guard, upper	1
10	009-0150	Nut HH M10-1.50 C6 Z MD	1
11	009-1446	Bolt HH M08-1.25x25 C8.8 Z F	1
12	31112154S	Bolt HH M08-1.25x40 C8.8 Z F	2
13	001-9451	Washer conical spring Ø8 Z	3

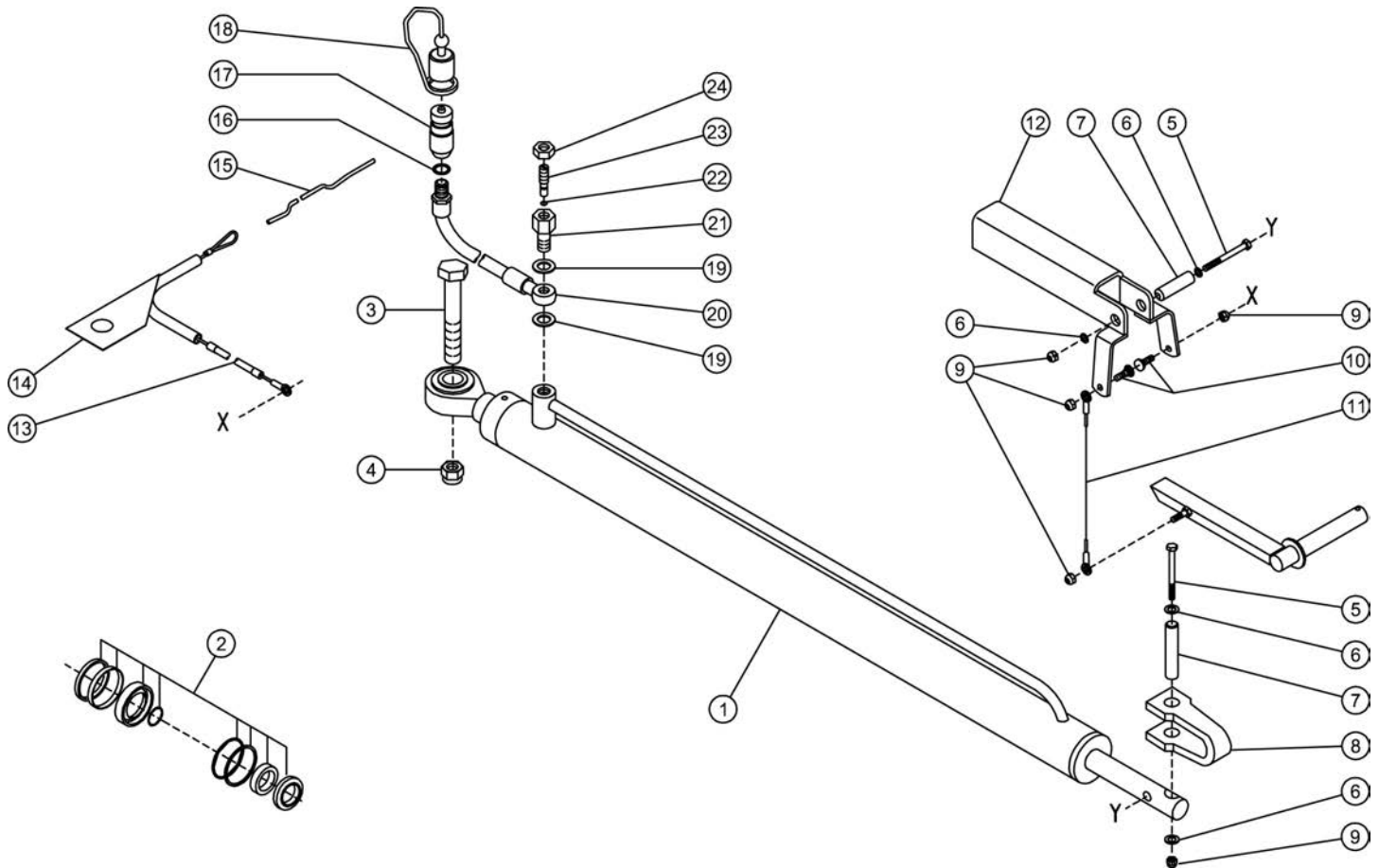

Ref.	Part #	Description	Qty.
1	58128770S	Hydraulic cylinder	1
	58136246S	Breather plug, hydraulic cylinder (not shown)	1
2	58128675S	Seal kit, hydraulic cylinder	1
3	31112500S	Bolt HH M20-1.50x70 C8.8 Z P	1
4	001-5641	Nut ES M20-1.50 Z TN	1
5	31112094S	Bolt HH M06-1.00x65 C8.8 Z P	2
6	001-1209	Washer fender Ø06 Z	4
7	34211126S	Roll pin Ø14x50	2
8	56128775NS	Yoke, hydraulic cylinder	1
9	005-0165	Nut ES M06-1.00 Z TK	5
10	008-8748	Bolt CR M06-1.00x20 C4.6 Z	2
11	58028885S	Cable	1
12	59228875S	Cylinder stop	1
13	58032489S	Cable w/sheath	1
14	59028776NS	Support	1
15	58032530S	Pull cord	1
16	000-6691	Washer aluminum sealing Ø18	1
17	58027119S	1/2" Male quick coupler M18-1.50x20F	1
18	006-3396	Rubber cap	1
19	005-7114	Washer copper sealing Ø14	2
20	58028888S	Hydraulic hose 5/16"x1700mm. Ø14 banjoxM18-1.50M	1
21	56129798S	Flow valve M12-1.75FxM14-1.50M	1
22	38110448S	Oil ring 2018	1
23	56329799S	Adjustment screw M12-1.75, flow valve	1
24	000-1106	Nut HH M12-1.75 C6 Z MD	1

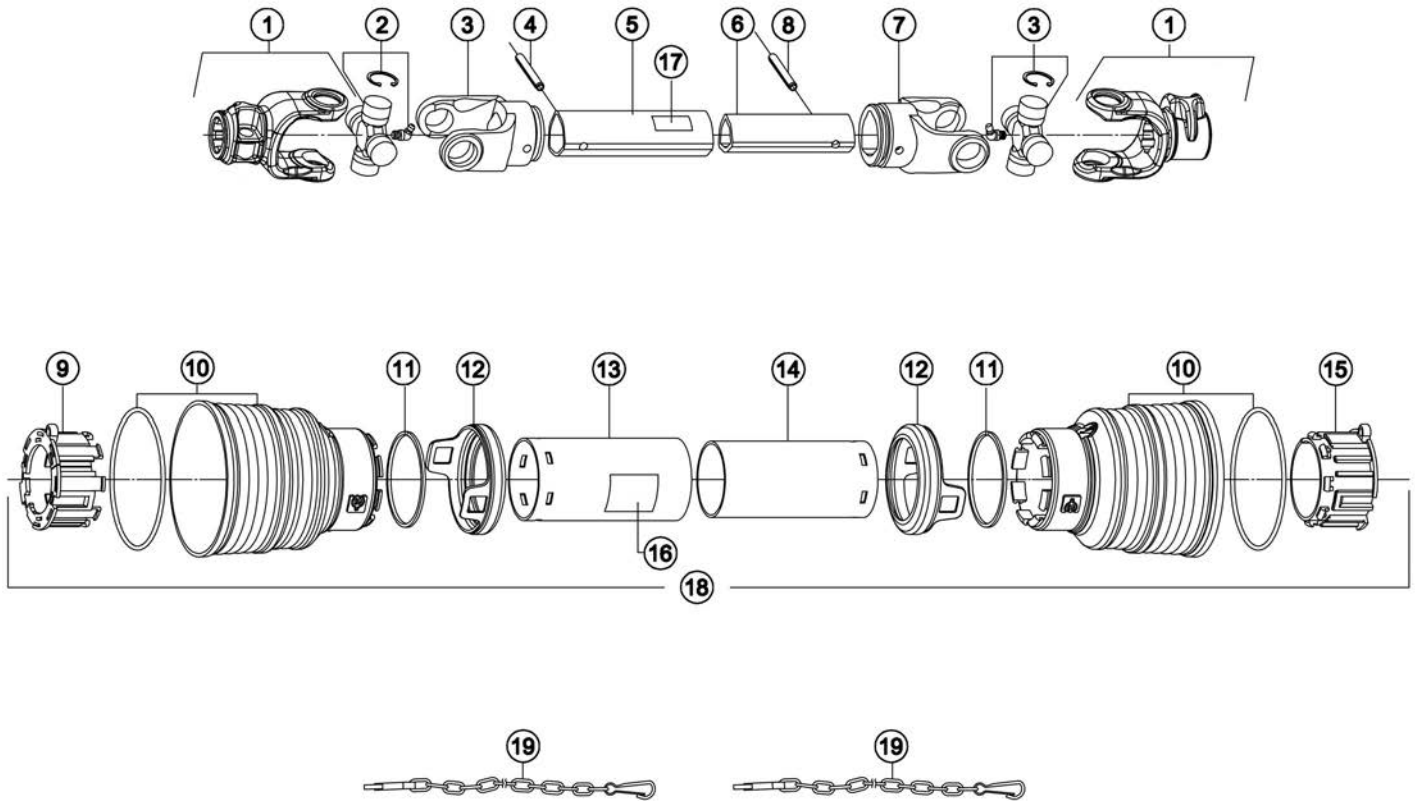

Ref.	Part #	Description	Qty.
1	1014013C	Yoke w/push collar	2
2	1004020C	Cross w/bearing	2
3	1704027C	Yoke, outer tube	1
4	001-8044	Roll pin Ø8x60	1
5	1524057C	Shaft, outer 570	1
6	1525057C	Shaft, inner 570	1
7	1704029C	Yoke, inner tube	1
8	000-8679	Roll pin Ø8x55	1
9	1784710C	Locking ring, outer tube	1
10	1781703C	Standard cone	2
11	1211735C	Safety ring	2
12	1881709C	Safety sleeve	2
13	1773049C	Shield, outer tube 490	1
14	1872049C	Shield, inner tube 490	1
15	1784711C	Locking ring, inner tube	1
16	1140010	Decal "rotating driveline" pictorial - ISO standard, outer shield	1
	950-463B	Decal "DANGER - Rotating driveline, keep away" outer shield	1
17	1140011	Decal "guard missing" pictorial - ISO standard, outer tube	1
	950-464B	Decal "DANGER - Guard missing, do not operate" outer tube	1
18	96SS4049C	Shield, complete	1
19	1006065C	Chain, anti-rotation	2
	050-0335	Driveline, complete	1

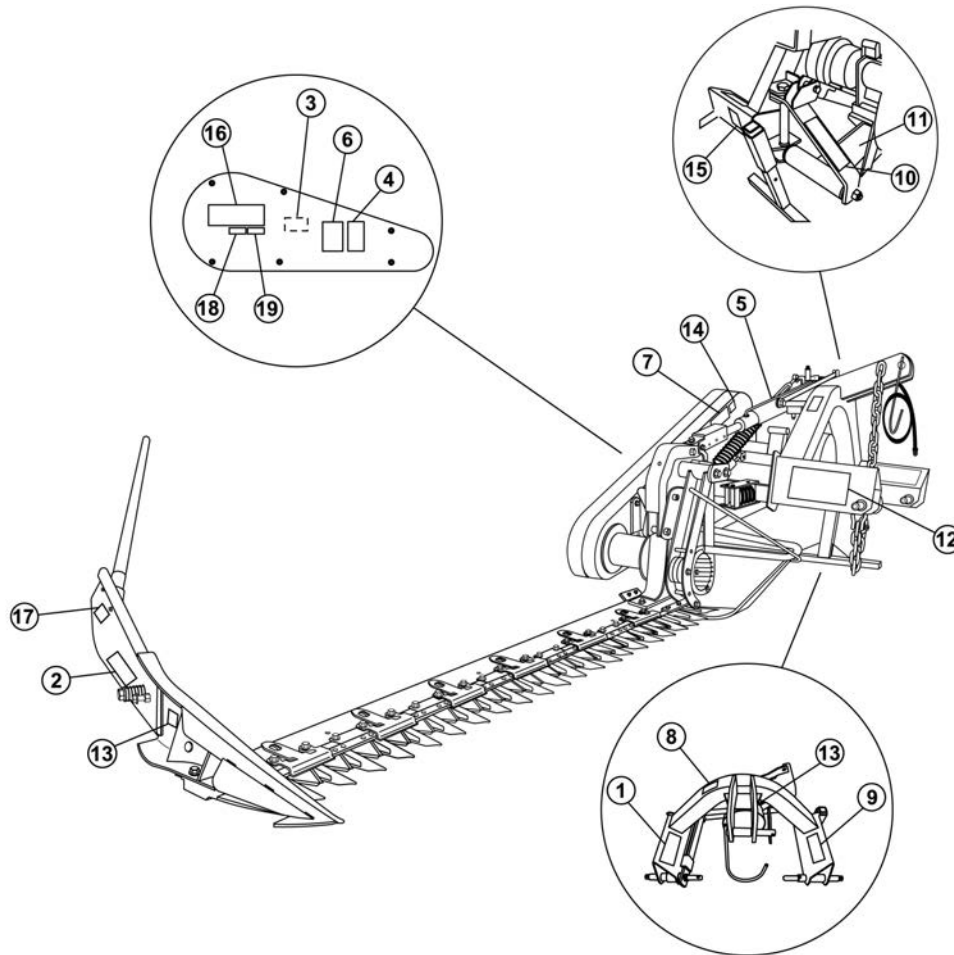

Ref.	Part #	Description	Qty.
1	950-109B	Decal "DANGER - Avoid injury from PTO"	1
2	950-955B	Decal "DANGER - Sharp blades"	1
3	950-213B	Decal "DANGER - Replace shields"	1
4	950-407B	Decal "WARNING - Crushing and pinching hazard"	1
5	950-408B	Decal "WARNING - High pressure hydraulic oil leaks"	1
6	950-111B	Decal "CAUTION - Read Operator's Manual"	1
7	58028664S	Decal "Periodically check belt tension"	1
8	58039274S	Decal "Max pressure"	1
9	58057724S	Decal "Read operator's manual"	1
10	58036548S	Decal "Work position"	1
11	58028942S	Decal "Work and transport position"	1
12	58028941S	Decal "Lubrication"	1
13	58028131S	Decal "Lifting location"	2
14	58028132S	Decal "540 rpm"	1
15	950-940B	Decal "Quick hitch compatible"	1
16	950-107B	Decal "Befco" md	1
17	950-103B	Decal "B" md	1
18	950-308B	Decal "BSB"	1
19	950-247B	Decal "272"	1
	950-248B	Decal "284"	1
	950-345B	Decal "296"	1

All rights reserved. It is unlawful to copy, reprint or use any of the information or details in this manual without the expressed written permission of the Company. Technical information provided in this manual is approximate, the Company reserves the right to modify or improve the models shown for technical or commercial purposes. Pictures in this manual do not necessarily show the machine as delivered.

Use only original spare parts

BEFCO BSB-272, 284, 296 (US).wpd
Printed in the USA, December 9, 2024

BEFCO[®]

P.O. Box 6036
Rocky Mount, NC 27802-6036
Tel.: 252.977.9920 - Fax: 252.977.9718
www.befco.com

