

BEFCO[®]

Operator's Manual

TURBO-HOP

Pendular Spreaders

303-600, 303-800, 303-999

(serial #304100 & above)

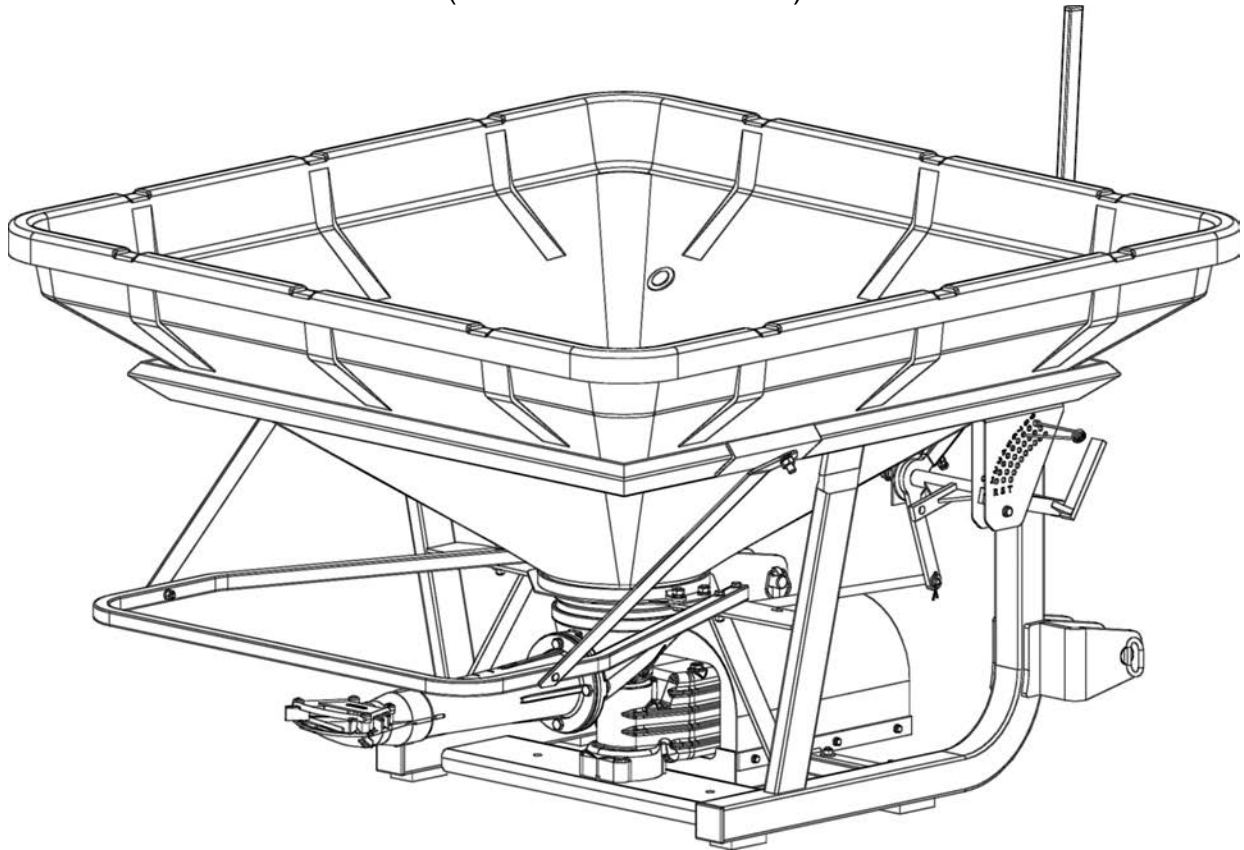

The operator's manual is a technical service guide and must always accompany the machine.

Manual 971-407B

November 2023

SAFETY

Take note! This safety alert symbol found throughout this manual is used to call your attention to instructions involving your personal safety and the safety of others. Failure to follow these instructions can result in injury or death.



*This symbol means:
ATTENTION!
BECOME ALERT!
YOUR SAFETY IS INVOLVED!*

Signal Words

Note the use of the signal words DANGER, WARNING and CAUTION with the safety messages. The appropriate signal words for each have been selected using the following guidelines:



DANGER: Indicates an imminently hazardous situation that, if not avoided, will result in death or serious injury.



WARNING: Indicates a potentially hazardous situation that, if not avoided, could result in death or serious injury, and includes hazards that are exposed when guards are removed. It may also be used to alert against unsafe practices.



CAUTION: Indicates a potentially hazardous situation that, if not avoided, may result in minor or moderate injury.

INDEX

1 - GENERAL INFORMATION	4
1.01 - General	4
1.02 - Warranty Information	4
1.03 - Model and Serial Number ID	5
2 - SAFETY PRECAUTIONS	6
2.01 - Preparation	6
2.02 - Starting and Stopping	7
2.03 - Messages and Signs	7
3 - OPERATION	10
3.01 - Operational Safety	10
3.02 - Set Up and Assembly	12
3.03 - Pre-Operational Check	13
3.04 - Attaching to the Tractor	14
3.05 - Start Up	16
3.06 - Operating Techniques	17
3.07 - Uneven Terrain	20
3.08 - Optional Filter Grate	21
3.09 - Optional Agitator Extension	21
3.10 - Optional Short Spout	22
3.11 - Optional Rubber Insert	22
3.12 - Optional Hydraulic Gate Control	22
3.13 - Optional Left/Right Directional Attachment	24
3.14 - Optional Locking Nut for Spout	25
3.15 - Optional Hopper Cover	26
3.16 - Spreading Charts	26
4 - MAINTENANCE	30
4.01 - Maintenance Safety	30
4.02 - Service	31
4.03 - Driveline	32
4.04 - Safety Shear Bolt	34
4.05 - Transport	34
5 - REPAIR PROCEDURES	36
5.01 - Suggested Spare Parts	36
5.02 - Storage	36
6 - TROUBLESHOOTING	37
7 - PRE-DELIVERY CHECKLIST	38
8 - WARRANTY	39

1 - GENERAL INFORMATION

Thank you and congratulations for having chosen our implement. Your new pendular spreader is a technologically advanced machine constructed of high quality, sturdy components that will fulfill your working expectations. Read this manual carefully. It will instruct you on how to operate and service your implement safely and correctly. Failure to do so could result in personal injury and/or in equipment damage.

1.01 - General

The implement described in this manual is to be used with tractors with PTO at 540 rpm and clockwise rotation.



CAUTION: Always ensure that the coupling of the implement with the tractor is done at the same PTO speed and direction of rotation. Do not operate this implement at a PTO speed or direction of rotation other than that shown on the implement. Serious damage can occur to the machine and/or the operator.



CAUTION: Unless otherwise specified, all hardware is metric. Use only metric tools on metric hardware. Other tools that do not fit properly can slip and cause injury.



CAUTION: Right hand and left hand sides of the implement are determined by facing in the direction the implement will travel when going forward (see fig. 2).

1.02 - Warranty Information

Carefully read the Warranty section¹, detailing coverage and limitations of this warranty. **Warranty** is provided for customers who operate and maintain their equipment as described in this manual. Warranty registration is accomplished by the dealer by completing and forwarding the **Warranty Registration** form to the Company, along with a copy of the dealer's invoice. It is in your best interest to insure that this has been done.

Warranty does not cover the following:

1. Cleaning, transporting, mailing and service call charges.
2. Normal wear items such as; bearings, drivelines, shear pins, bronze slide, etc.

¹ See Chapter 8 - Warranty.

3. Depreciation or damage caused by normal wear, accidents, improper maintenance, improper protection or improper use.
4. The use of non-original spare parts and accessories.

Your Authorized Company Dealer has genuine parts in stock. Only these approved replacement parts should be used.

This limited warranty covers defective material and workmanship. The cost of normal maintenance or repairs for accidents or improper use and related labor will be borne by the owner.

1.03 - Model and Serial Number ID

Attached to the frame is an ID plate showing the model and the serial number. Record your implement model and serial number in the space provided below. Your dealer needs this information to give you prompt, efficient service when you order parts.

BEFCO	1781 S. Wesleyan Blvd. – P.O. Box 6036 Rocky Mount, N.C. 27802 – U.S.A. Tel: 1.252.977.9920 Fax: 1.252.977.9718
MODEL:	<input type="text"/>
SERIAL:	<input type="text"/>
VERSION:	<input type="text"/>

2 - SAFETY PRECAUTIONS

Safety is the primary concern in the design and manufacture of our products. Unfortunately our efforts to provide safe equipment can be wiped out by a single careless act of an operator.

In addition to the design and configuration of equipment, hazard control and accident prevention are dependent upon the awareness, concern, prudence and proper training of personnel involved in the operation, transport, maintenance and storage of equipment.

It is the operator's responsibility to read and understand all safety and operating instructions in the manual and to follow these.

Allow only properly trained personnel to operate the fertilizer spreader. Working with unfamiliar equipment can lead to careless injuries. Read this manual, and the manual for your tractor, before assembly or operation, to acquaint yourself with the machines. It is the spreader owner's responsibility, if this machine is used by any person other than yourself, is loaned or rented, to make certain that the operator, prior to operating, reads and understands the Operator's Manuals and is instructed in safe and proper use.

2.01 - Preparation



1. Before operating equipment read and understand the Operator's Manual and the safety signs (**see fig. 2**).
2. Thoroughly inspect the implement before initial operation to assure that all packaging materials, i.e., wires, bands, and tape have been removed.
3. Personal protection equipment including hard hat, safety glasses, safety shoes, and gloves are recommended during assembly, installation, operation, adjustment, maintaining and/or repairing the implement.
4. Operate the fertilizer spreader only with a tractor equipped with an approved Roll-Over-Protective-System (ROPS). Always wear your seat belt. Serious injury or even death could result from falling off the tractor.
5. Clear area of stones, branches or other debris that might be thrown, causing injury or damage.
6. Operate only in daylight or good artificial light.
7. Ensure fertilizer spreader is properly mounted, adjusted and in good operating condition.
8. Ensure that all safety shielding and safety signs are properly installed and in good condition.
9. Chemicals may cause eye, skin or breathing problems. Always wear a face mask, gloves and goggles when filling hopper.
10. Before loading the fertilizer in the hopper read carefully the instructions printed on the fertilizer canvas bag concerning the precautions to be taken in case of toxicity or

corrosivity of the product. Before loading switch off the engine and remove the ignition key.

11. Load hopper with product only after the spreader has been properly attached to the tractor.

2.02 - Starting and Stopping



1. Be sure that no one is near the machine prior to engaging or while the machine is working.
2. Be sure the tractor is in "Neutral" before starting engine.
3. The operating power is supplied from tractor PTO. Refer to your tractor manual for PTO engagement and disengagement instructions. Always operate PTO at 540 rpm. Know how to stop the tractor and machine quickly in case of an emergency.
4. When engaging PTO, the engine rpm should always be low. Once engaged and ready to start operating, raise PTO speed to 540 rpm and maintain throughout operation.
5. Check the tractor master shield over the PTO stub shaft. Make sure it is in good condition and fastened securely to the tractor. Purchase a new shield if old shield is damaged or missing.
6. After striking an obstacle, disengage the PTO, shut the tractor down and thoroughly inspect for damage before restarting.
7. To park the vehicle safely, stop vehicle on a level surface (not on a slope), disengage PTO, engage the parking brake, stop the engine, remove the key, and wait for engine and all moving parts to stop before leaving the operator's seat.
8. Stay clear of rotating drivelines. Entanglement in rotating driveline can cause serious injury or death. Wear close fitting clothing. Stop the engine and be sure PTO driveline is stopped before getting near it.

2.03 - Messages and Signs



1. Read and adhere to all safety and operating decals on this machine (**see fig. 2**).
2. Before dismounting tractor: Stop engine, set brake and remove the key of unattended equipment.
3. Keep away from rotating parts and driveline.
4. Keep guards and shields in place and in good condition.
5. Do not use with bystanders in area.
6. Allow no riders on tractor or fertilizer spreader.
7. Allow moving parts to stop before repair.
8. Securely support fertilizer spreader before working underneath.

Additional warning and operating decals are available at no extra charge. Please specify model and serial number when ordering.

Fig. 2 - Safety decals - implement; replace immediately if damaged.

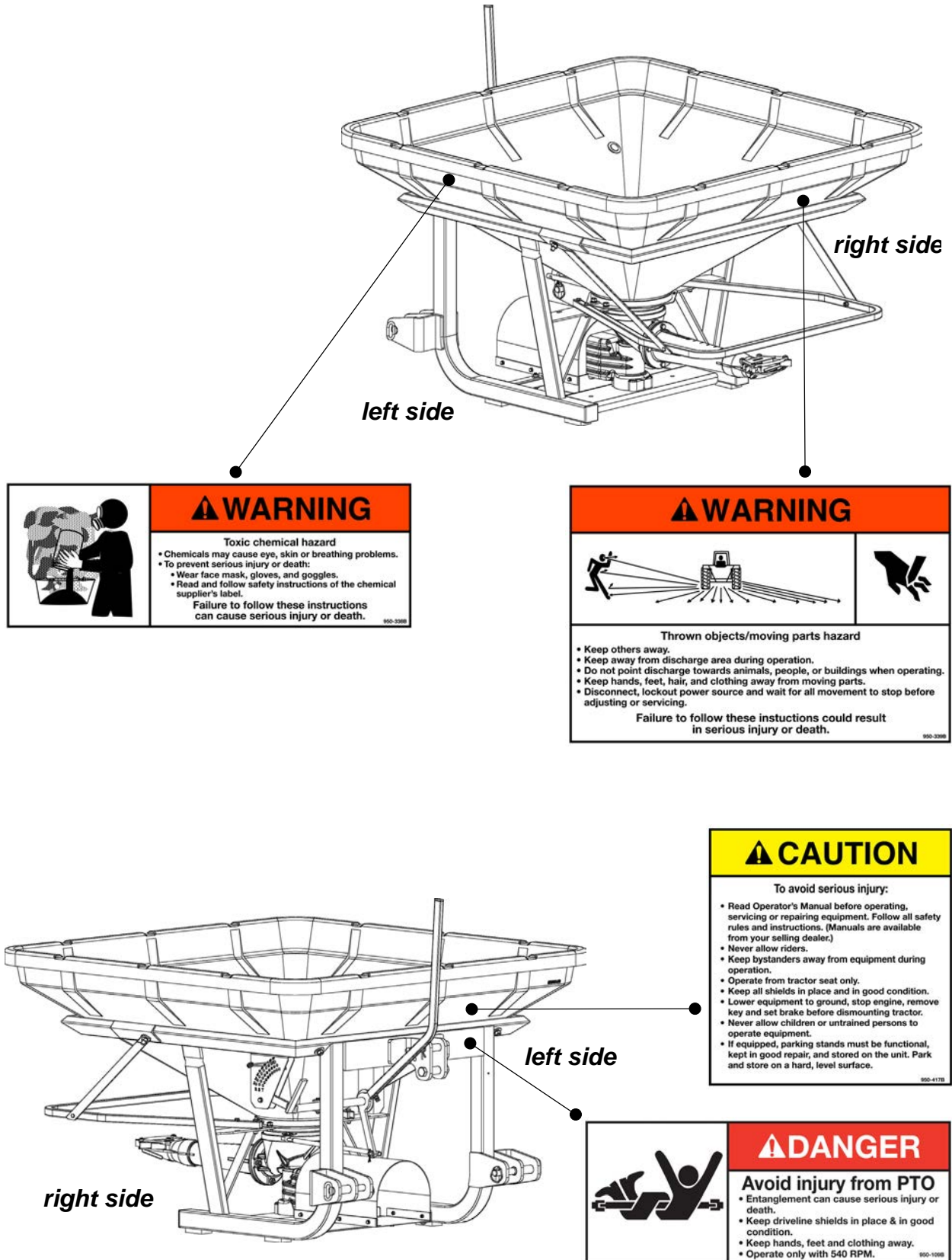

Safety decals - driveline; replace immediately if damaged.

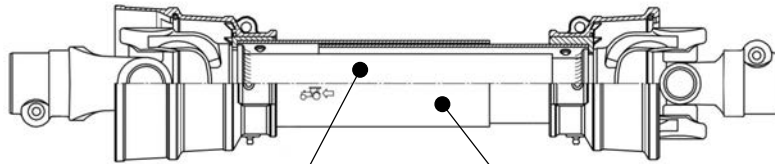

placed on outer tube



placed on outer shield

3 - OPERATION

The fertilizer spreader is an extremely versatile and accurate machine, ideal for spreading not only granular or powdered material but also for spreading materials containing a humidity percentage of up to 30 percent.

Pendular spreaders can spread up to a width of 47' and are designed for 20 to 60 HP tractors.

By rotating the spout 90 degrees left or right, the spreader will send material only in that direction, allowing the operator to spread material only on desired spots and minimize wasted material. The pendular spreader is also particularly suited for spreading corrosive material since components that come in contact with these are made of either stainless steel or polyethylene.

3.01 - Operational Safety



CAUTION: Our spreaders are designed considering safety as the most important target and are the safest available in today's market. Unfortunately, human carelessness can override the safety features built into our machines. Injury prevention and work safety, aside from the features on our spreaders, are very much due to the responsible use of the equipment. It must always be operated prudently following with great care, the safety instructions laid out in this manual.



1. The use of this equipment is subject to certain hazards which cannot be prevented by mechanical means or product design. All operators of this equipment must read and understand this entire manual, paying particular attention to safety and operating instructions, prior to using.
2. Do not operate the tractor and spreader when you are tired, sick or when using medication.
3. This spreader is designed for use only on tractors with 540 rpm power take off.
4. Only properly trained people should operate this machine.
5. Accidents are most likely to occur with machines that are loaned or rented to someone who has not read the Operator's Manual and is not familiar with a spreader.
6. Always stop the tractor, set brake, shut off the tractor engine, remove the ignition key, and allow spreader moving parts to come to a complete stop before dismounting tractor. Never leave equipment unattended with the tractor running.
7. Never place hands or feet into hopper with tractor engine running or before you are sure all motion has stopped. Stay clear of all moving parts.

8. Never allow any person inside the hopper for any reason. Serious injury or death can result from someone becoming entangled in the agitator.
9. Do not allow riders on the spreader or tractor at any time. There is no safe place for riders.
10. Never allow anyone within 100 yards of the spreader while the PTO is engaged. Product thrown from the spreader can cause serious injury or death.
11. Before backing up, look behind carefully.
12. Install and secure all guards and shields before starting or operating.
13. Keep hands, feet, hair and clothing away from moving parts.
14. Never operate tractor and spreader under trees with low hanging limbs. Operator can be knocked off the tractor and then run over.
15. Stop spreader immediately upon striking an obstruction. Turn engine off, remove key, inspect and repair any damage before resuming operation.
16. Inspect the entire machine periodically². Look for loose fasteners, worn or broken parts, and leaky or loose fittings.
17. Stay alert for holes, rocks and roots in the terrain and other hidden hazards. Keep away from drop-offs.
18. Use extreme care and maintain minimum ground speed when transporting on hillside, over rough ground and when operating close to ditches or fences. Be careful when turning sharp corners.
19. Reduce speed on slopes and sharp turns to minimize tipping or loss of control. Be careful when changing directions on slopes. Do not start or stop suddenly on slopes. Avoid operation on steep slopes.
20. Pass diagonally through sharp dips and avoid sharp drops to prevent "hanging up" tractor and spreader.
21. Avoid sudden starts and stops while traveling up or downhill.
22. Always operate down slopes; never across the face. Avoid operation on steep slopes. Slow down on sharp turns and slopes to prevent tipping and/or loss of control.
23. All remote control devices (cables, ropes, rods, flexible lines, etc.) should be positioned in a way to prevent maneuvers which could lead to accidents or damages.
24. Chemicals may cause eye, skin or breathing problems. Always wear a face mask, gloves and goggles when filling hopper.
25. Before loading the fertilizer in the hopper read carefully the instructions printed on the fertilizer canvas bag concerning the precautions to be taken in case of toxicity or corrosivity of the product. Before loading switch off the engine and remove the ignition key.
26. Load hopper with product only after the spreader has been properly attached to the tractor.
27. Use only the driveline supplied with the spreader. Do not use it if it is missing any shield or safety protection. Frequently check the driveline and ensure it is in good operating condition. Immediately replace broken or damaged shields or protections.

² See Chapter 4 - Maintenance.

3.02 - Set Up and Assembly

Notice to dealer: Pre-Delivery set up and service including lubrication are the responsibility of the authorized dealer. It is up to him to assure that the machine is in perfect condition and ready to be used. It is his responsibility to ensure that the customer is aware of all safety aspects and operational procedures for the spreader. He must also fill out the Pre-Delivery Checklist³ prior to delivering the spreader.



CAUTION: Stand clear of bands when cutting as they could be under sufficient tension to cause them to fly loose. Take care in removing bands and wire, as they often have extremely sharp edges and cut very easily.

Note: All hardware needed for assembly will be found in the crate and the hardware bag of the machine. Assembly will be easier if all parts are loosely assembled before tightening the hardware.

Fig. 3 - Spout and guard assembly.

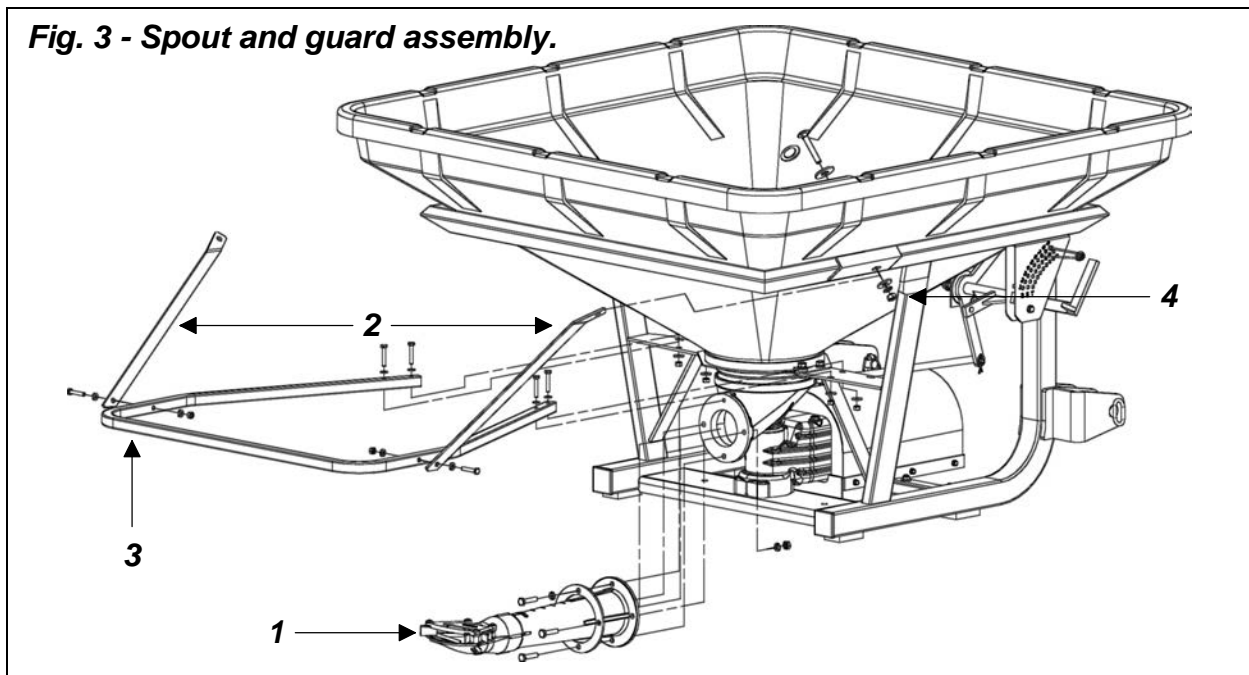

To assemble the pendular spreader proceed as follows:

1. Slide the spout ring over the discharge chute and secure them to the gearbox using the M10x45 bolts, Ø10 lock washers and M10 nuts (**see #1, fig. 3**). Note: The M10x45 bolt on the top hole does not require a nut on the other side as it screws directly into the gearbox housing.
2. Attach the left and right protection attachment plates (**see #2, fig. 3**) to the “U” shaped protection (**see #3, fig. 3**) using the M8x45 bolts, Ø8 washers and M8 nuts. Make sure to assemble the plates with the bent ends facing upwards and outwards.

³ See Chapter 7 - Pre-Delivery Checklist.

3. Secure the protection (**see #3, fig. 3**) to the spreader frame using the M8x45 bolts, Ø8 washers on top and the Ø8 fender washers and M8 nuts on the bottom.
4. Remove the M12 nuts that secure the back of the hopper to the frame (**see #4, fig. 3**) and slide protection attachment plates (**see #2, fig. 3**) into the M12 bolts. Once in position secure the protection attachment plates to the frame with the M12 nuts.

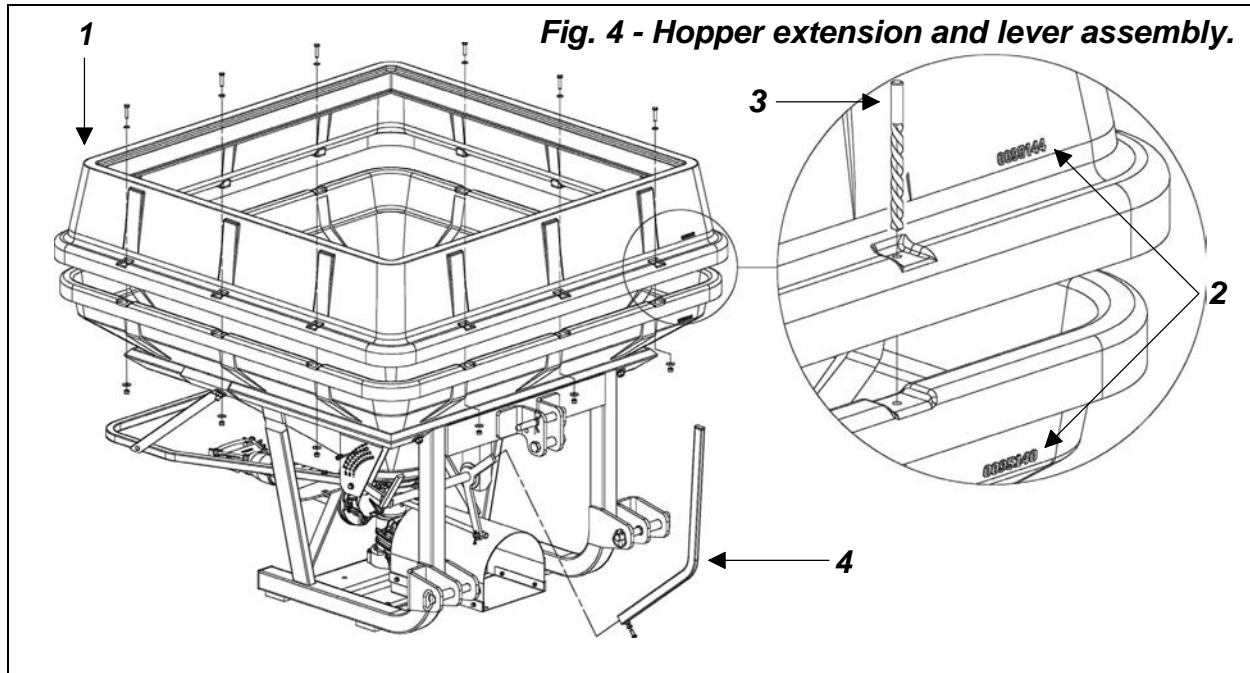

5. On spreader models 303-800 and 303-999, place the hopper extension over the hopper (**see #1, fig. 4**). Verify that the part number on both the hopper and the extension are lined up above one another (**see #2, fig. 4**). Once the extension is properly in place, drill Ø9 holes in the pre-spaced slots through the hopper extension and the hopper (**see #3, fig. 4**). Secure the hopper extension to the hopper using the M8x35 bolts, Ø8 washers and M8 nuts.
6. Place the opening lever (**see #4, fig. 4**) over the lever bracket and secure it with the M8x20 bolt and M8 jam nut. Note: When using the spreader with a quick hitch, place the opening lever in the outer position on the lever bracket. This will allow for the lever to open and close properly without interference with the quick hitch (**see fig. 6**).
7. Tighten all hardware securely.

3.03 - Pre-Operational Check

Check each of the following, carefully, prior to engaging the equipment:

1. Thoroughly read and understand your operator's manual.
2. The oil in the gearbox.
3. The driveline cross and bearings have been greased.
4. No wrappings or foreign objects are around the machine or driveline.
5. All hardware is tight⁴.

⁴ Refer to Table 1 - Torque Specifications, page 35.

6. The tractor, to ensure correct direction of PTO and rpm speed.
7. All safety shields and guards are in place and tightly attached.
8. No people or animals are in the work area.



DANGER: Shut off the tractor and remove the key before making adjustments, servicing or cleaning the machine.

3.04 - Attaching to the Tractor

Only use pendular spreaders with tractors in the correct power range⁵ with PTO speed of 540 rpm that turns clockwise and category 1 or 2 three point hitch. Never use with tractors over 60 HP.

Fig. 5 - Attaching to the tractor.

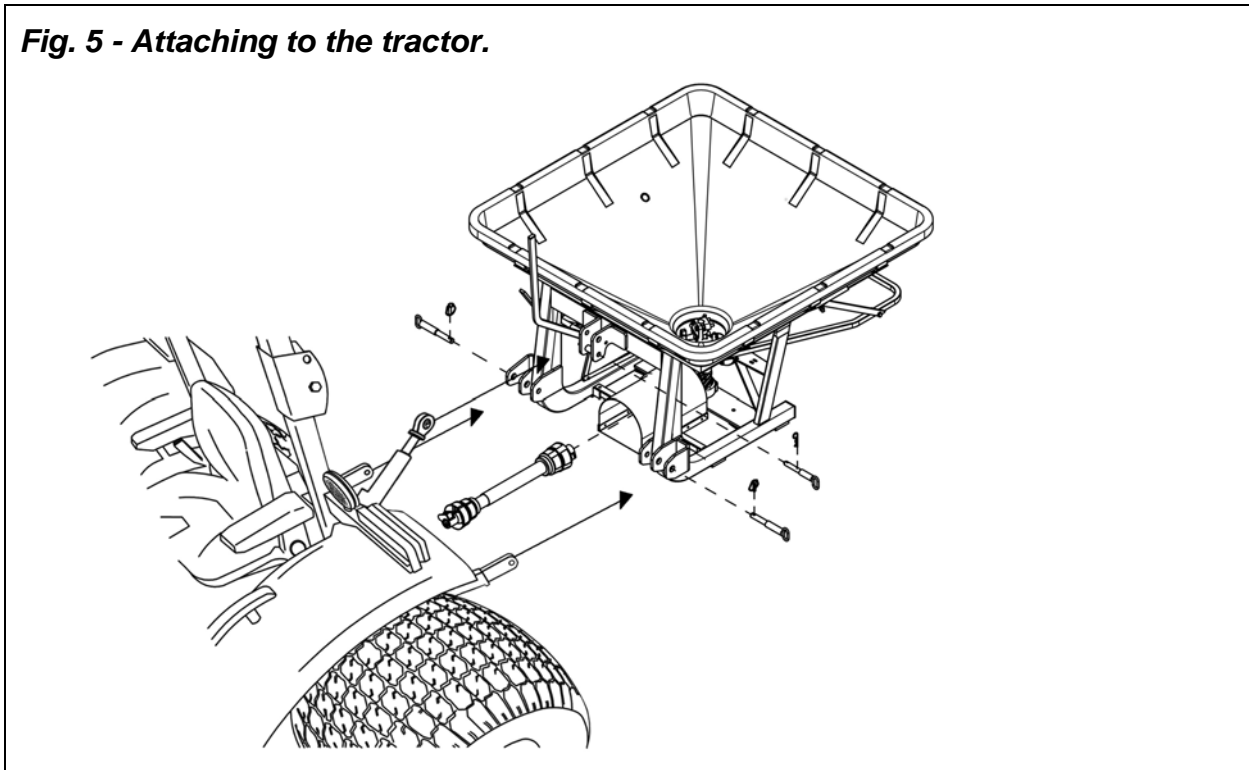

WARNING: Never attempt to attach the implement to the tractor or make adjustments to it without first turning the tractor off.

⁵ Refer to Table 2 - Technical Features, page 35.



CAUTION: Check the tractor PTO rpm to ensure it is set at 540 rpm and turns clockwise.



CAUTION: Be sure the tractor tire pressure is correct. It is important to strictly follow the safety guidelines and instructions laid out in the tractor manual.

To attach the pendular spreader to the tractor proceed as follows (**see fig. 5**):

1. Back the tractor to the spreader until the draft links align with the hitch pins.
2. Stop engine, engage parking brakes and remove key before dismounting tractor.
3. Secure the draft links to the hitch pins and secure them in place with lynch pins.
4. Attach top link to the top hitch of the spreader using the hitch pin and secure it with the cotter pin.
5. Adjust the tractor sway chains/bars to center the spreader behind the tractor and control the side sway.
6. Ensure the spreader is leveled by adjusting both the draft links and the top link.
7. Install the shock joint side of the driveline to the spreader. Be sure each end of the driveline is connected securely with the locking pin. Connect the driveline shielding chains to the tractor and to the implement to prevent the protective shielding from rotating during operation. If it was necessary to remove the PTO shielding to do any of the above operations, do not forget to replace it. Ensure that the driveline has at least 2" from bottoming out in its shortest working position and has the minimum 6" overlap in its longest working position. Refer to **Section 4.03⁶** of this manual if it is determined that the driveline is too long and needs to be shortened. Contact your local dealer if it is determined that the driveline is too short for your tractor.

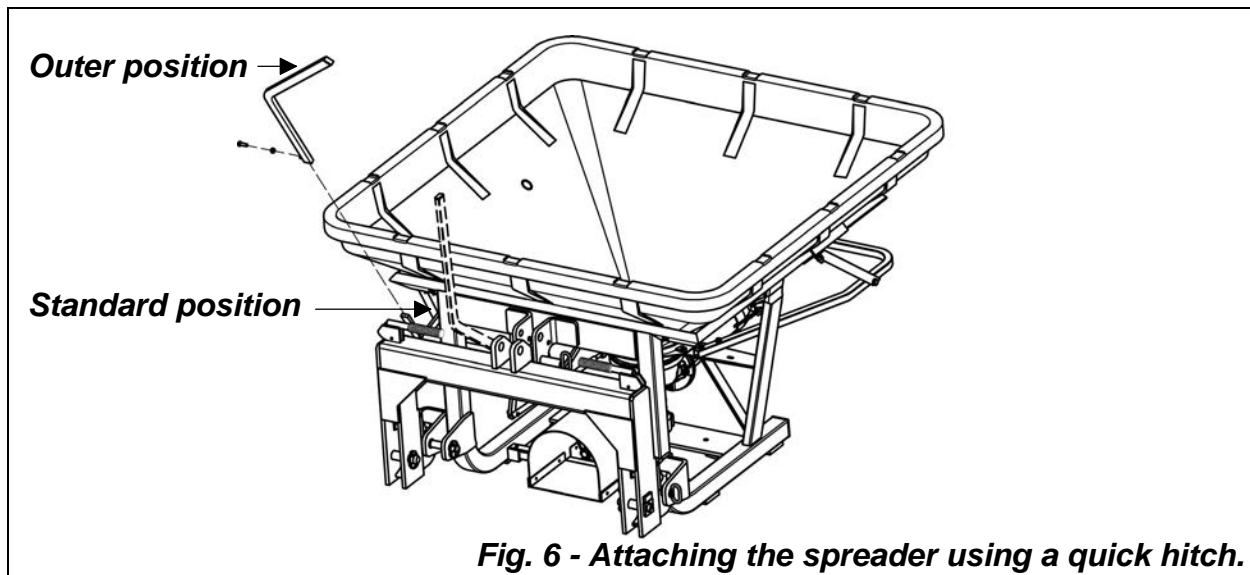

Fig. 6 - Attaching the spreader using a quick hitch.

⁶ See Section 4.03 - Driveline, for instructions on how to determine correct driveline length and procedures for shortening the driveline.

Models 303-600, 303-800 and 303-999 are designed to be category 1 and 2 quick hitch compatible. When using the spreader with a quick hitch, place the opening lever in the outer position on the lever bracket. This will allow for the lever to open and close properly without interfering with the quick hitch (**see fig. 6**).

3.05 - Start Up



CAUTION: Load hopper with product only after the spreader has been properly attached to the tractor.



WARNING: Chemicals may cause eye, skin or breathing problems. Always wear a face mask, gloves and goggles when filling hopper. Refer to chemical manufacturer's label for specific safety information.

Before starting to use, never forget that the **operator is responsible** for the following:

1. Safe and correct driving of the tractor and spreader.
2. To learn precise, safe operating procedures for both the tractor and the spreader.
3. To ensure all maintenance and lubrication has been performed on the spreader.
4. To have read and understood all safety aspects for the spreader in the Operator's Manual.
5. To have read and understood all safety decals on the spreader.
6. Checking the tractor tires for the proper pressure in accordance with the tractor Operator's Manual.
7. **Checking that all shields are on the machine and securely in place.**
8. Making sure the proper attire is worn. Avoiding loose fitting clothing which can become entangled. Wearing sturdy, tough-soled work shoes and protective equipment for eyes, hands, ears and head. Never operate tractor or implements in bare feet, sandals or sneakers.
9. Ensuring proper lighting is available, sunlight or good artificial lighting.



WARNING: Use a tractor with a cab and appropriate filters on the ventilation system or wear a breathing mask capable of filtering toxic powders to prevent inhalation of product.

Prior to start working do the following:

1. Make sure there are no obstructions.
2. Run machine under a no-load condition for a short while to assure that everything is functioning properly.
3. Adjust all settings for the desired quantity distribution and spread pattern.

4. Shift the transmission to a slow speed gear and start forward, increase the ground speed by shifting upward until the desired speed is obtained. Do not use in reverse unless absolutely necessary and only after careful observation of the area behind the spreader.

3.06 - Operating Techniques



WARNING: Before adjusting the spreader or filling the hopper, be sure the tractor PTO is not engaged, the tractor is shut off, and the key is removed from the tractor ignition.



WARNING: Before engaging the PTO, be sure no persons or animals are behind or beside the spreader.



DANGER: Never allow anyone within 100 yards of the spreader while the PTO is engaged. Product thrown from the spreader can cause serious injury or death.



DANGER: Never allow any person inside the hopper for any reason. Serious injury or death can result from someone becoming entangled in the agitator.

The material delivery is controlled by a lever that opens the orifices in the hopper bottom. The lever has up to 27 positions that it can be locked into depending on the desired output. To ensure a constant output of product always keep the following factors into account.

The quantity of material distributed per acre depends on the following factors:

1. Tractor ground speed.
2. Unit weight and size of the material to be spread.
3. Spreading width.
4. Position of the lever connected to the hopper gates.

The working speed depends on ground conditions. Only a test run will enable you to gauge the optimal working speed for your conditions.

Spread adjustment

Fill the hopper with the desired material to be spread. Be sure the gates are in the closed position. Raise the spreader with the tractor lift arms until the pendular spout is approximately 28 inches from the ground and with the spreader as parallel to the

ground as possible (see fig. 7). Place the gauge pin in the desired hole position (see fig. 22)⁷. Do not open the gates at this time.

Engage the engine PTO. The spreader is designed to run at 540 rpm at the PTO. Lower or greater PTO speed will change the discharge pattern. Start the tractor forward and open the gates by lowering the lever until it stops against the pin. Close off the gates with the lever after finishing spreading.

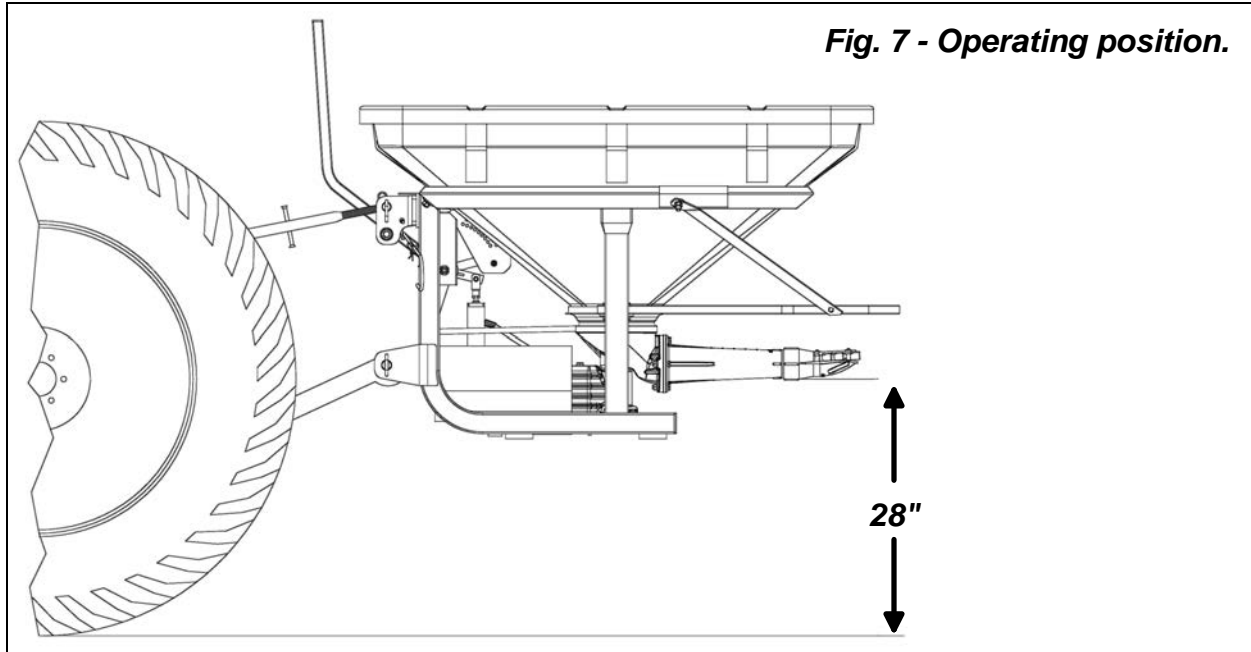

Spreading width

Our pendular spreaders are designed to spread a variety of different materials and therefore the spread width will vary greatly depending on the type of material you are trying to spread. With the standard spout mounted, the spreader will spread powdered materials between 17' and 20' and granular materials between 39' and 47' (see fig. 8).

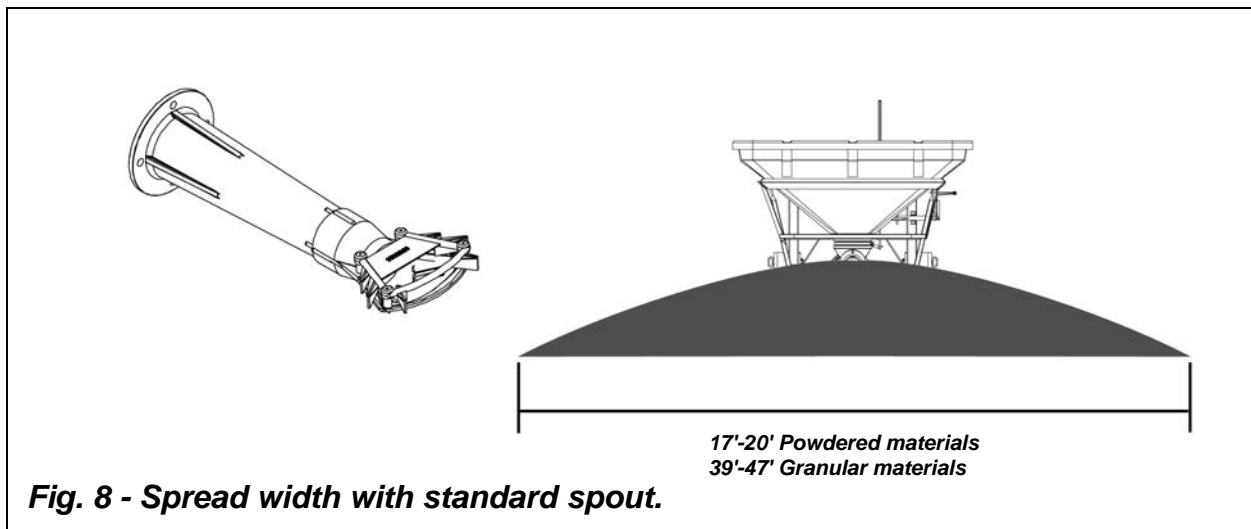

17'-20' Powdered materials
39'-47' Granular materials

⁷ See Section 3.16 - Spreading Charts.

Only a test run will enable you to determine the actual spreading width of the material you are trying to spread.

Field spread pattern

The amount of material distributed by the pendular spreaders will always be greater directly behind the unit and will gradually decrease farther away from the spreader. To obtain a uniform spread throughout the field, the operator will need to maintain parallel travel patterns on the field making sure to maintain a distance from the previous pass that is equal to $\frac{1}{2}$ of the total spreading width (see fig. 9).

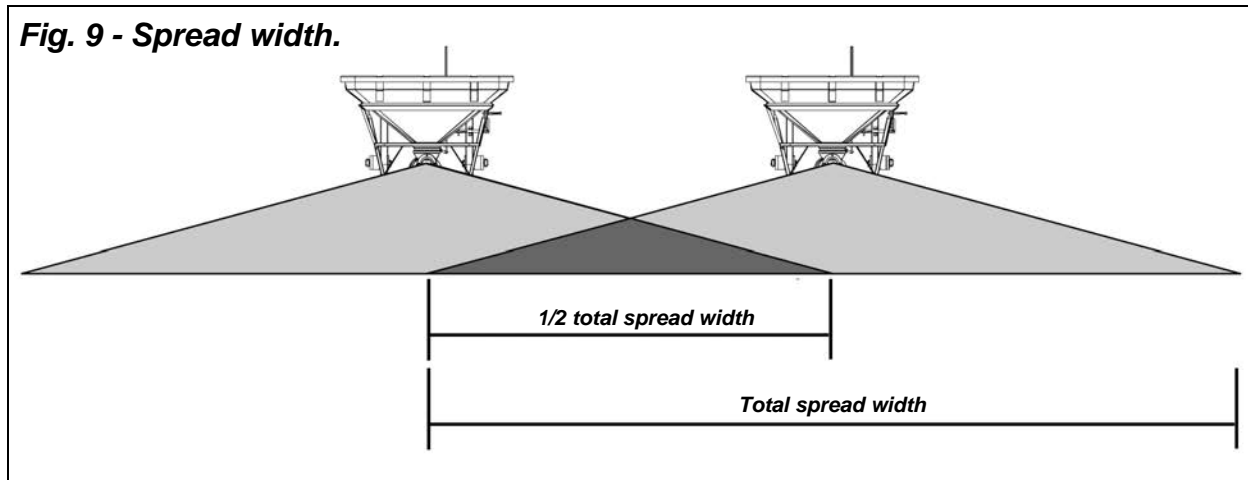

When spreading over a field, position the tractor in a corner at a distance equal to $\frac{1}{2}$ of the total spread width away from the edge of the field. Spread first around the perimeter of the field. After covering the perimeter, drive the tractor in parallel patterns up and down the field at a distance equal to $\frac{1}{2}$ of the total spread width from the previous pass until the field has been completely covered (see fig. 10).

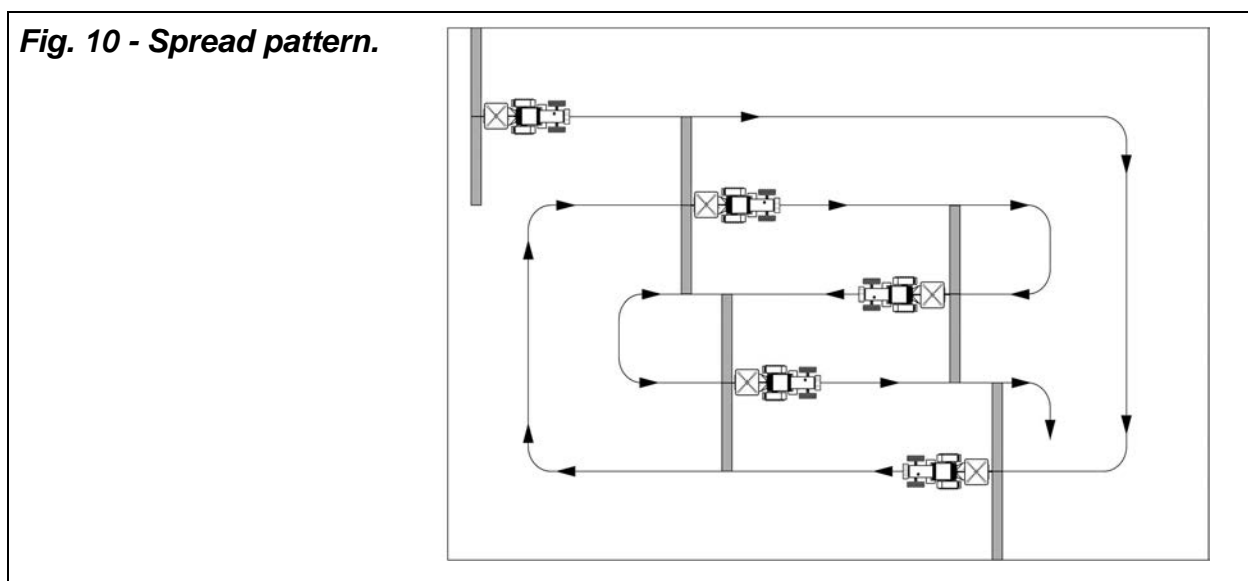

Band spreading

Spreading in bands is when the spreader only distributes material off to the sides and none in the middle. By unscrewing the spread deflector from the end of the spout, the spreader will now spread material only to the sides. The standard spout may need to be cut to obtain the desired banding width. In its original length the spreading spout will leave a band of approximately 23' and drop the material in rows roughly 3' wide. The spout can be cut in small increments if the desired width needs to be reduced. At 1/4 of its' original length the spreader spout will leave a band in the middle of approximately 6.5' and still drop material in rows roughly 3' wide (see fig. 11).

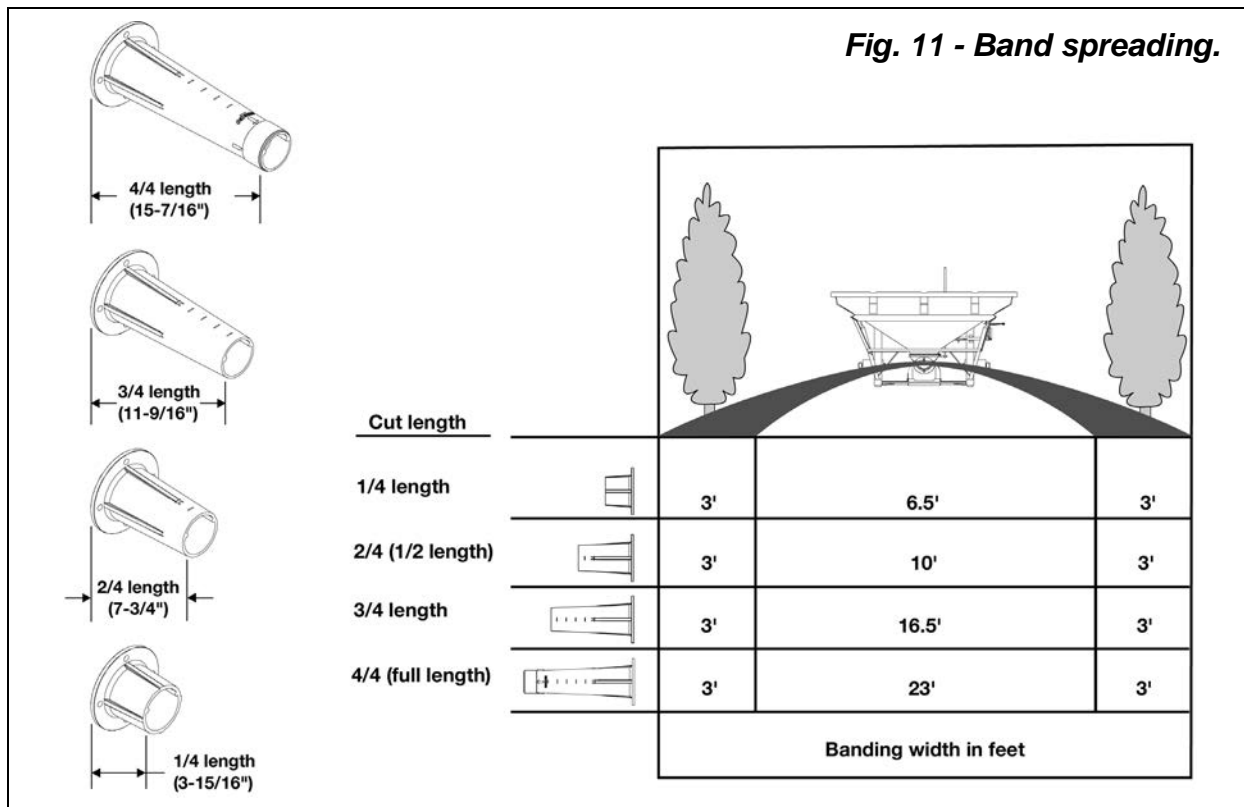

3.07 - Uneven Terrain



WARNING: Be careful of roll-over when operating tractor and spreader over uneven ground.

The following precautions should always be observed when working on uneven terrain:

1. In extremely uneven terrain rear wheel weights, front tractor weights, and/or tire ballast should be used to improve stability.
2. Observe the type of terrain and develop a safe working pattern.
3. Whenever traction or stability is doubtful, first test drive over the terrain.

4. Operate the implement up and down steep slopes, not across slopes, to prevent the tractor from tipping. Avoid sudden stops and starts, slow down before changing directions on a slope.
5. Pass diagonally through sharp dips and avoid sharp drops to prevent hanging up the tractor and implement.
6. Slow down on sharp turns and slopes to prevent tipping or loss of control.
7. Watch for holes, roots or other hidden objects. Do not use near the edge of a gully, ditch or stream bank.

3.08 - Optional Filter Grate

The filter grate (see fig. 12) is a simple bolt-on accessory, ideal for filtering clots and foreign objects from the material being spread.

Fig. 12 - Optional filter grate.

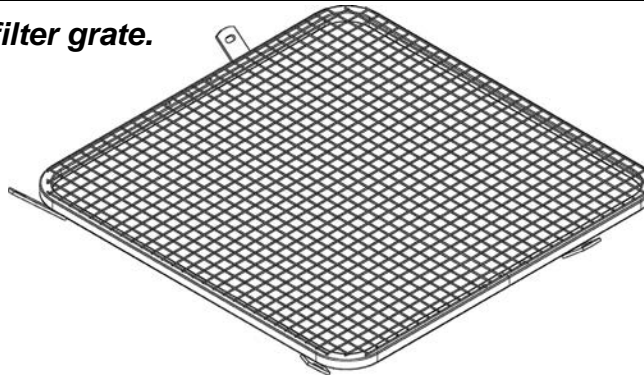

3.09 - Optional Agitator Extension

The agitator extension (see fig. 13) is an accessory useful when powdered or high humidity fertilizer is being spread. This type of material has a tendency to bridge in the hopper. The agitator extension is assembled on the existing agitator using the supplied spring. Important: Heavy clods such as compacted salt must be broken up before being used in the spreader.

Fig. 13 - Optional agitator extension.

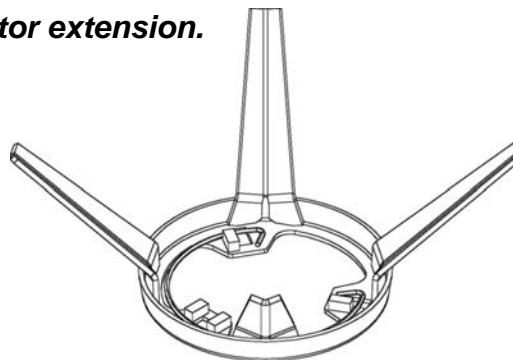

3.10 - Optional Short Spout

The short spout (**see fig. 14**) is used to cut the spread width in half. To assemble, remove the standard spout that is bolted to the spreader and assemble the short spout in its place.

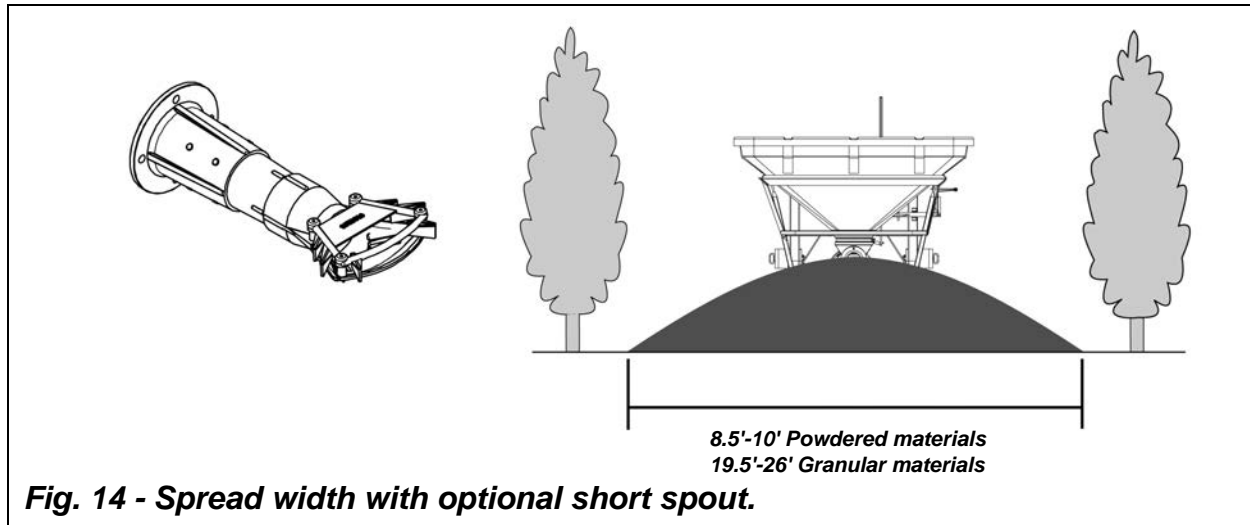

3.11 - Optional Rubber Insert

The rubber insert is available for all pendular spreader models and is used when spreading high moisture product such as damp fertilizer or peat. The rubber insert provides a high viscosity surface that lets humid material flow through the spout better.

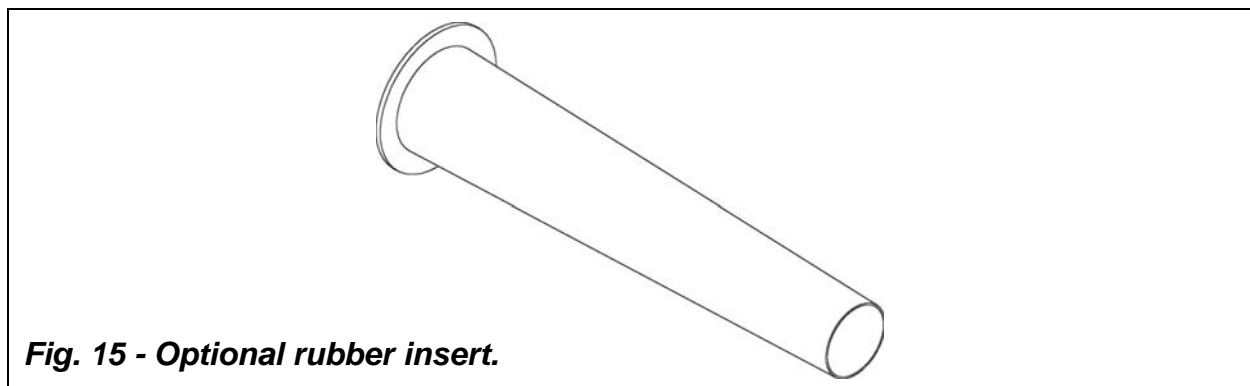

3.12 - Optional Hydraulic Gate Control

The hydraulic gate control allows the operator to control the opening and closing of the gate using the tractor's hydraulic system. Two hydraulic remotes are required on the tractor to operate the spreader.

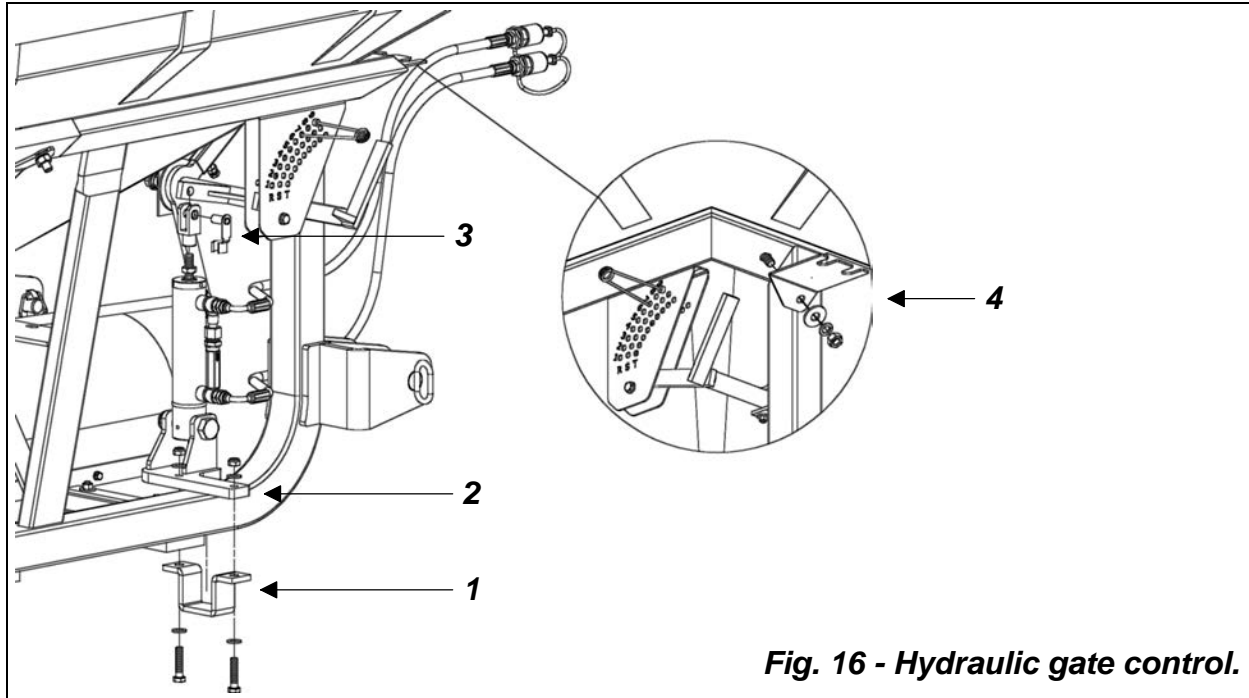

Fig. 16 - Hydraulic gate control.



WARNING: High pressure hydraulic oil leaks can penetrate skin resulting in injury, gangrene or death. Be sure to relieve any hydraulic oil pressure before disconnecting any lines or pipes between spreader and tractor hydraulic system. Check for oil leaks using a cardboard, never use hands.

The hydraulic gate control is designed to be assembled to the front right hand side of the pendular spreader below the graded scale. To assemble, proceed as follows:

1. With the spreader unhooked from the tractor and positioned on stable ground, slide the back plate of the mounting bracket under the tube of the frame until it is close to the block welded on the bottom of the frame (**see #1, fig. 16**).
2. Position the mounting bracket (**see #2, fig. 16**) with the cylinder and hydraulic remotes facing forward, over the back plate, so that the holes on the mounting bracket line up with the holes on the back plate. Secure the two brackets using M10x45 bolts, Ø10 washers and M10 nuts.
3. Remove the fixing pin that is assembled to the top cylinder yoke (**see #3, fig. 16**). Line up the hole on the top cylinder yoke with the hole on the opening lever bracket that is on the spreader. Slide the fixing pin through the holes and secure it on the yoke. Note: The hydraulic remote gate control will work better when the cylinder can operate perfectly vertical on the spreader, therefore once the yoke is secured, it may be necessary to adjust forward or backwards the position of the mounting brackets in order to align the cylinder.
4. Remove the M12 nut, Ø12 lock washer and the Ø12 fender washer from the bolt that secures the hopper to the frame on the front right hand part of the spreader (**see #4, fig. 16**), place the hydraulic hose retainer plate with the slots facing outwards through the bolt and secure with the hardware previously removed.

5. Remove the opening lever from the frame as it will not function with the hydraulic remote gate control assembled.
6. Position hydraulic hoses in a safe route towards the tractor and place the remotes on the hose retainer bracket.
7. Tighten all hardware securely.



CAUTION: Hydraulic pressure relief valve is preset at 508 psi and should not be replaced with one that has a higher pressure. Increasing the pressure can result in damage to the equipment.

3.13 - Optional Left/Right Directional Attachment

Although the standard spread deflector can be adjusted to spread only to the left or only to the right, the optional directional attachment (**see fig. 17-20**) improves accuracy when spreading in either direction. To assemble, unscrew the standard spread deflector and screw in the left/right directional attachment.

Fig. 17 - Optional directional attachment turned left on standard spout.

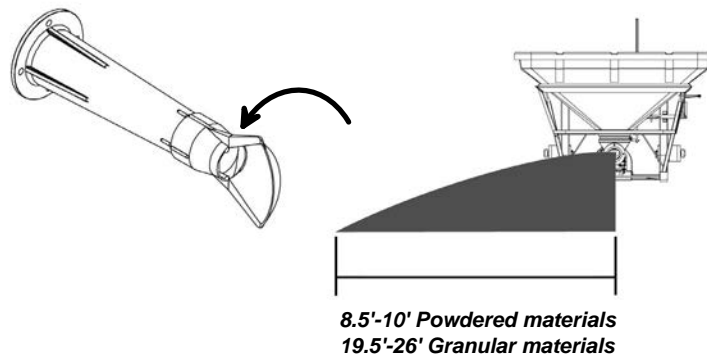

Fig. 18 - Optional directional attachment turned right on standard spout.

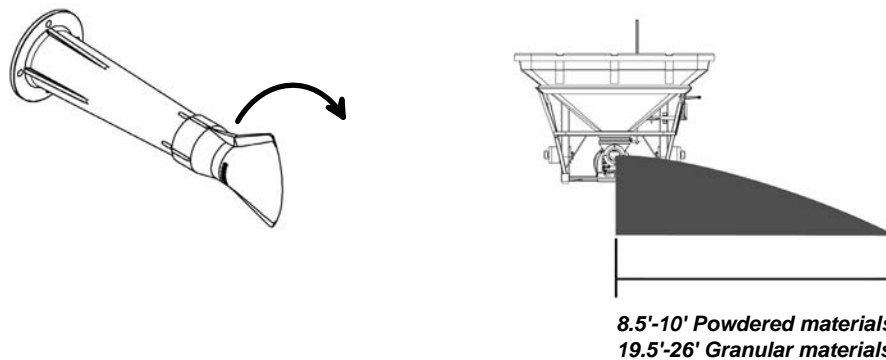

Fig. 19 - Optional directional attachment turned left on short spout.

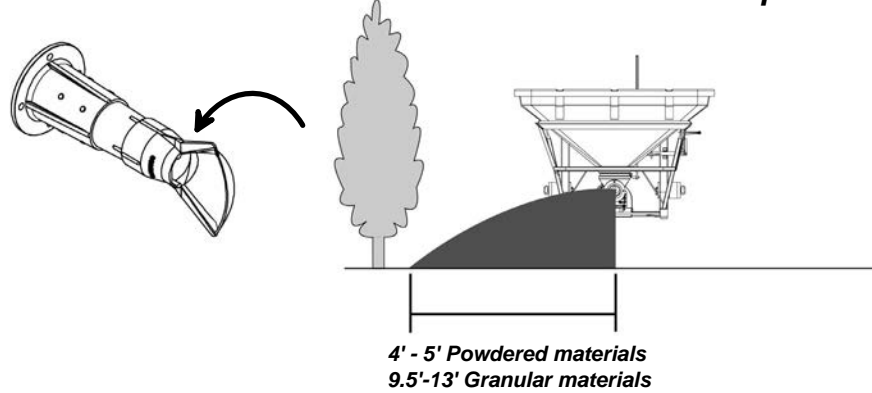
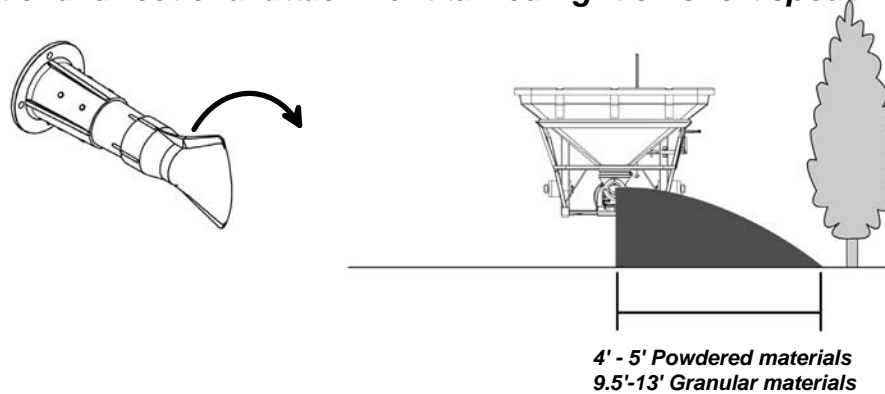

Fig. 20 - Optional directional attachment turned right on short spout.



3.14 - Optional Locking Nut for Spout

The galvanized locking nut (**see fig. 21**) available for the spout is ideal when the operator often has to change the spreading direction on the spout. This accessory allows user to adjust the spout to spread in the desired direction and to be held in place with the help of the locking nut. To assemble, unscrew the spread deflector, screw in the locking nut, screw the spout to desired position and use locking nut to tighten.

Fig. 21 - Optional locking nut.



3.15 - Optional Hopper Cover

The hopper cover is available for all models. This heavy duty cover helps to keep moisture out of the material being spread. Cover also prevents powdered material from being blown over the top of the hopper before being spread.

Spreader model	Hopper cover needed
303-600	009-9725
303-800	009-9726
303-999	009-9727

3.16 - Spreading Charts

The graded scale located on the side of the spreader allows the operator to predetermine the desired opening of the distribution unit. There are three lines of holes marked with letters R, S, T (see fig. 22). Each line has 9 holes, which are offset by 4 mm. from one another for a total of 27 different opening positions. This system offers a quick and accurate adjustment of the distribution unit. The spread tables in the following pages will help you determine what setting to use according to the type of product you are spreading. The figure below illustrates the hole selection for "4S".

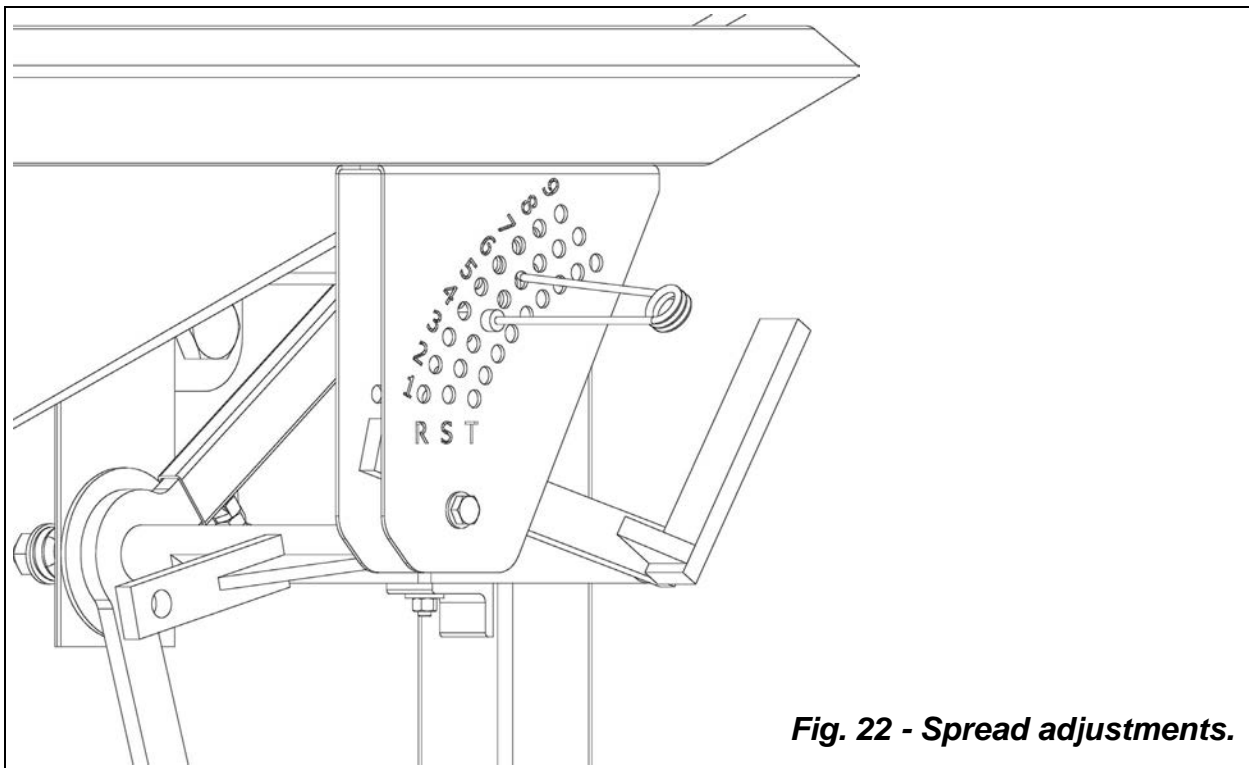

Fig. 22 - Spread adjustments.

PTO 540 rpm		Spread Table in Lbs./Acre																											
Type of fertilizer	Spread width ft.	Work speed m.p.h.	LEVER POSITION																										
			1R	1S	1T	2R	2S	2T	3R	3S	3T	4R	4S	4T	5R	5S	5T	6R	6S	6T	7R	7S	7T	8R	8S	8T	9R	9S	9T
Complex 12.12.12	39	3.7				32	52	73	93	130	166	203	259	316	371	435	500	564	623	682	741	842	942	1044	1077	1110	1144	1156	1178
		5				24	38	54	70	97	124	153	194	236	277	327	375	422	467	511	556	632	707	783	807	832	858	867	883
		6.2				20	31	44	55	79	100	122	155	189	222	261	300	338	374	409	444	505	566	626	646	666	686	694	698
		7.5				16	26	37	46	65	83	102	129	158	186	218	250	282	311	341	370	421	471	522	538	555	572	578	589
		8.7				13	22	31	41	56	71	87	111	136	160	186	214	241	267	292	318	361	403	447	461	476	490	495	505
Superphosphate	39	3.7				18	37	57	77	109	143	175	225	273	323	380	439	496	567	641	712	792	874	955	1014	1074	1133	1151	1169
		5				13	28	43	57	81	107	131	169	204	242	285	329	372	426	480	532	594	656	716	760	806	850	863	876
		6.2				11	22	34	46	65	86	105	135	164	194	228	263	298	341	385	426	476	525	573	608	644	680	691	701
		7.5				9	19	29	38	54	71	87	112	137	161	190	219	248	284	320	356	396	437	477	507	537	567	575	584
		8.7				8	16	24	32	46	62	75	96	117	138	163	188	212	244	275	305	339	375	410	435	460	485	493	501
Ammonium Nitrate	39	3.7				50	82	114	146	194	241	289	360	432	503	582	662	741	853	965	1078	1137	1196	1255	1292	1329	1367	1378	1388
		5				37	62	86	109	145	180	217	270	324	377	436	496	556	640	724	808	852	897	941	969	997	1024	1033	1041
		6.2				30	49	69	87	117	145	173	216	259	302	349	397	444	512	579	646	682	717	753	775	798	820	826	833
		7.5				25	41	57	73	97	120	145	180	216	252	291	331	370	426	483	539	568	598	628	646	665	683	689	694
		8.7				21	35	49	62	83	103	124	154	185	216	249	284	318	366	414	462	487	512	538	554	569	585	591	595
Calcium Nitrate	33	3.7							70	102	136	170	219	268	318	378	439	500	566	630	696	776	857	937	1030	1121	1213	1249	1280
		5							53	76	102	127	164	201	237	284	329	375	424	472	522	583	642	703	772	840	910	937	960
		6.2							42	61	81	101	132	161	190	227	263	300	339	378	418	466	514	562	617	673	724	749	768
		7.5							35	51	68	85	110	134	159	189	219	250	283	315	348	388	428	468	515	560	607	625	640
		8.7							29	44	58	72	94	115	136	162	188	214	243	270	298	333	367	401	442	480	520	535	549
Ammonium Sulfate	23	3.7				59	111	162	214	287	360	434	553	671	790	917	1046	1172	1329	1486	1643	1829	2013	2198	2222	2243	2266	2293	2306
		5				44	83	121	161	215	270	325	415	503	592	688	784	880	997	1114	1232	1371	1510	1648	1666	1682	1700	1719	1730
		6.2				36	66	97	128	172	216	260	332	402	474	550	627	703	798	891	986	1097	1208	1319	1333	1345	1361	1376	1384
		7.5				29	55	81	107	144	180	217	277	335	395	459	523	586	665	743	822	915	1006	1099	1111	1121	1133	1146	1153
		8.7				25	47	70	92	123	154	186	237	287	338	393	448	502	570	637	704	783	863	942	952	961	972	982	989
Magnesium Potassium Sulfate	36	3.7				25	50	77	102	145	189	232	291	348	407	464	519	576	657	739	819	923	1028	1131	1184	1237	1289	1326	1338
		5				19	37	57	77	108	142	173	218	261	304	348	389	432	492	554	615	691	771	848	888	927	967	995	1004
		6.2				15	30	46	61	87	113	138	175	209	244	278	311	345	394	443	492	553	617	679	710	742	774	796	803
		7.5				12	25	38	51	72	95	116	145	174	203	232	260	288	328	369	410	461	514	566	592	618	645	663	669
		8.7				11	21	33	44	62	81	99	125	149	174	199	222	246	281	317	351	395	440	484	508	530	552	568	574

4 - MAINTENANCE



DANGER: Stop engine, lock parking brake and remove key before performing any service or maintenance.

Always use personal protection devices, such as a breathing mask capable of filtering toxic powders, safety glasses and gloves, when performing maintenance.

Refer to chemical manufacturer's label for specific safety information.

Keep fingers out of slots to prevent injury.

4.01 - Maintenance Safety



1. Good maintenance is your responsibility.
2. Keep service area clean and dry. Be sure electrical outlets and tools are properly grounded. Use adequate light for the job at hand.
3. Make sure there is plenty of ventilation. Never operate the engine of the towing vehicle in a closed building. The exhaust fumes may cause asphyxiation.
4. Make no repair or adjustments with the tractor engine running. Before working on the machine, disengage the PTO, shut off the engine, set the brakes, and remove the ignition key.
5. Be certain all moving parts on attachment have come to a complete stop before attempting to perform maintenance.
6. Never work under equipment unless it is blocked securely.
7. Always use personal protection devices such as eye, hand and hearing protectors, when performing any service or maintenance.
8. Never trust the tractor hydraulics alone to support the machine. Before repairing or adjusting the machine, it should be lowered and allowed to rest on a stand.
9. Periodically tighten all bolts, nuts and screws and check that all cotter pins are properly installed to ensure unit is in a safe condition.
10. When completing a maintenance or service function, make sure all safety shields and devices are installed before placing unit in service.
11. Do not attempt to mount a tire unless you have the proper equipment and experience to do the job.
12. Inflating or servicing tires can be dangerous. Whenever possible, trained personnel should be called to service and/or mount tires.
13. After servicing, be sure all tools, parts and service equipment are removed.
14. Never replace hex bolts with less than grade five bolts unless otherwise specified, i.e. shear bolts⁸.

⁸ Refer to Table 1 - Torque Specifications, for head identification marking, page 35.

15. Where replacement parts are necessary for periodic maintenance and servicing, genuine replacement parts must be used to restore your equipment to original specifications. The company will not claim responsibility for use of unapproved parts and/or accessories and other damages as a result of their use.
16. Unauthorized modifications to the machine may impair the function and/or safety of the machine and reduce its life. If equipment has been altered in any way from original design, the manufacturer does not accept any liability for injury or warranty.

4.02 - Service

Before beginning work:

1. Apply a thick layer of grease to all exposed moving parts.
2. Apply a film of biodegradable oil in crevices and corners in order to keep corrosive material from rusting areas that are difficult to clean.
3. Every 8 hours check the gearbox oil level with dipstick (**see fig. 23**). (Use SAE 90W lubricant).

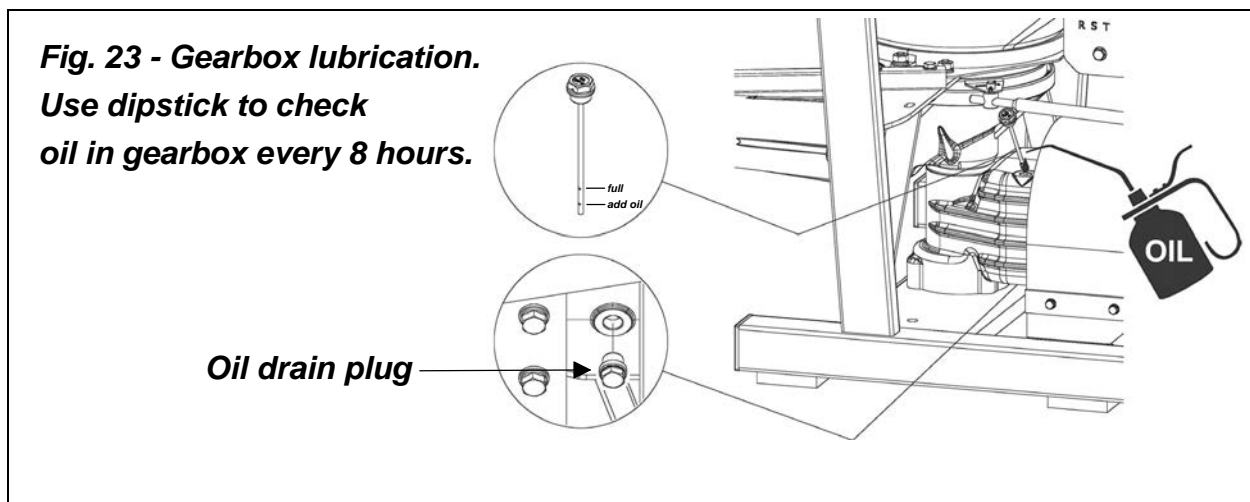

After each use:

1. Be sure to thoroughly wash the machine without using excessive pressure especially on the moving parts. It is particularly important to wash the implement after using salt or fertilizer. This will help prevent the caustic chemicals in the salt and fertilizer from damaging the metal of the machine.
2. Carefully dry the machine.
3. Apply a thick layer of grease to all exposed moving parts.
4. Apply a film of biodegradable oil in crevices and corners.
5. Grease the driveline cross and bearing and shielding (**see fig. 24**).
6. Grease the telescoping inner and outer tubes (**see fig. 24**).

IMPORTANT: Periodically check the bronze slide (009-5190) inside the gearbox. This is the heart of the machine and its condition will determine how the spreader runs. When the flywheel is turned by hand, there should be no jerking movement.

The flywheel and the spout should move as one. If there are stops and starts, this may be an indication of wear on the bronze slide and it should be replaced immediately. Failure to do so can create problems to other parts of the spreader.

Fig. 24 - Driveline lubrication points.

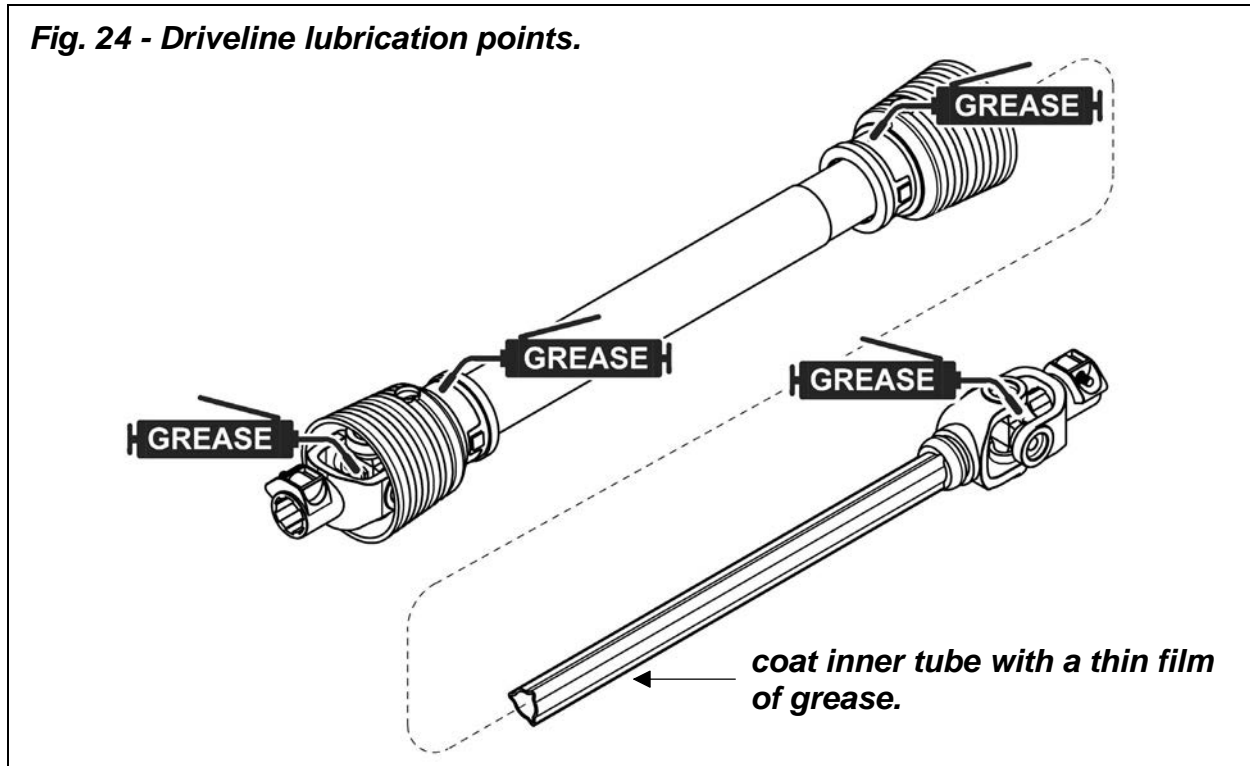

4.03 - Driveline



DANGER: Only use the original driveline supplied with this machine and always with safety shielding installed and working properly. Carefully read and file away the driveline operator's manual supplied by the manufacturer. The following does not substitute the information found in the driveline manual.

IMPORTANT: Always check driveline length during initial setup and when connecting to a different tractor.

In the collapsed position the driveline should be approximately 2" from bottoming out to prevent possible damage to the tractor or implement. When the driveline is in the maximum extended position, the ideal minimum overlap of the two halves should be approximately 6" (see fig. 25).

If determined that the driveline is too long, follow these procedures to adjust the length:

1. Separate the two driveline halves. Connect one half to the tractor PTO and the other half to the spreader.

2. Raise and lower the spreader with the three point hitch to find the position where the driveline is shortest. Hold the halves' shafts side by side and mark the desired length on the outer female tube guard leaving a 2" gap between the end of the guard tube and bell guard.
3. Cut off both guard tubes the same amount as marked in step 2.
4. Shorten both drive tubes the same amount as guard tubes.
5. De-burr and clean filings from drive tubes and apply grease to outside of inner telescoping tube.
6. Reassemble the driveline halves and connect to tractor and implement. Raise and lower implement again to be sure driveline does not bottom out in its shortest position and has a minimum overlap of 6" in the longest position.
7. Install both driveline safety chains. One should be hooked in a hole on the outer driveline yoke shield and to the tractor to restrict outer shield rotation. The second one should be hooked in a hole on the inner driveline yoke shield and to the implement to restrict inner shield rotation.

Fig. 25

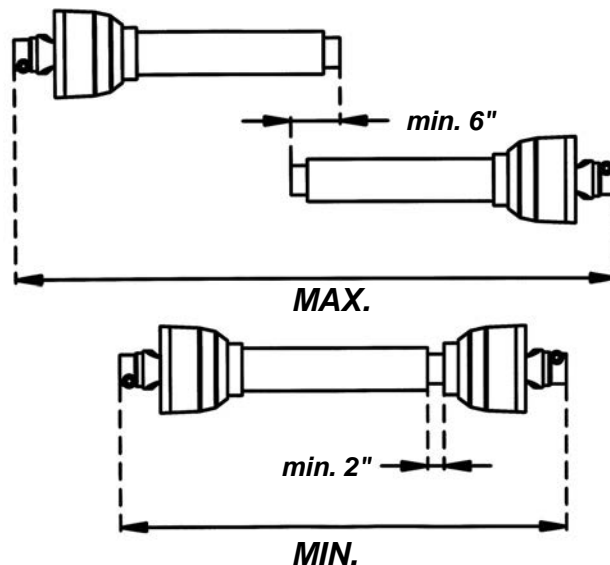

If the driveline has less than minimum overlap, do not use and contact your Authorized Company Dealer.



CAUTION: Always work with the driveline as straight as possible. This will prolong its life and that of its components. It is advised not to work at an angle greater than 15 degrees.

4.04 - Safety Shear Bolt



CAUTION: When this machine is equipped with a shear bolt driveline, for the protection of the PTO and gearbox, never replace the shear bolt with anything harder than a class 8.8 bolt. All warranties will be void if a bolt harder than a class 8.8 is used.

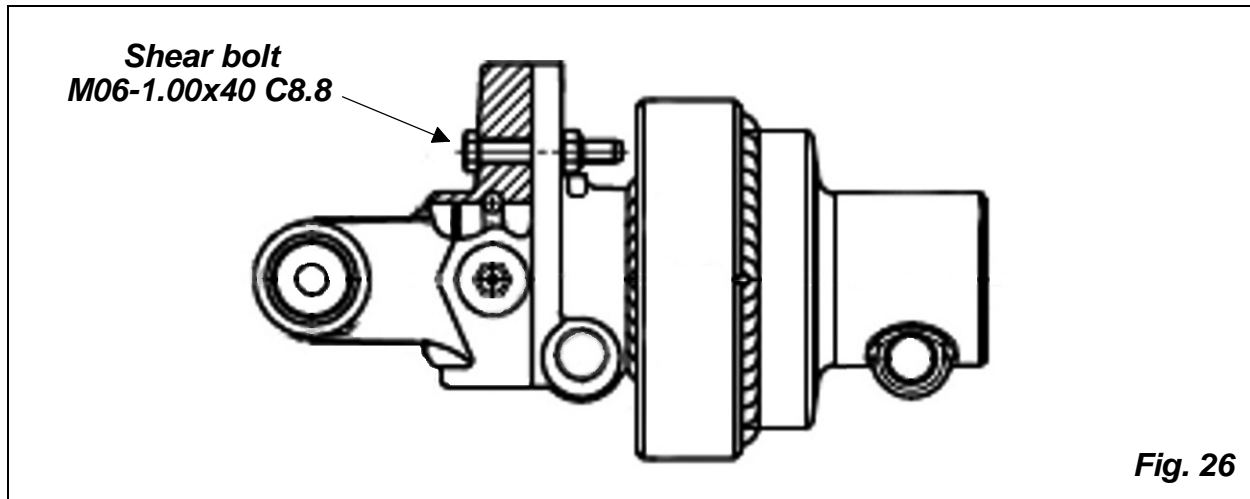

Fig. 26

In the case of a shear bolt breaking (the operator will notice that the spreader will stop even though the tractor PTO is still engaged), disengage the PTO, stop and turn off the tractor. **Replace the broken shear bolt M06-1.00x40 C8.8 with another having the identical characteristic of the original (see fig. 26).**

Substituting different shear bolts other than those indicated by the manufacturer can render the safety inoperable.

4.05 - Transport









CAUTION: Do not tow tractor and spreader behind other vehicles. Use a properly equipped trailer with heavy tie-downs for towing operations.

Before transporting:

1. Always select a safe ground speed that is appropriate for the terrain.
2. Beware of traffic on public roads. Install a SMV (Slow Moving Vehicle) sign when traveling on roads or streets.
3. Reduce ground speed when turning and take care that the spreader does not strike obstacles such as trees, fences or buildings.

TABLE 1 - TORQUE SPECIFICATIONS

Metric (ISO) treaded bolts head marking		 Class 5.8	 Class 8.8	 Class 10.9	Inch (SAE) treaded bolts head marking		 Grade 2	 Grade 5	 Grade 8						
Bolt size mm	Thread mm	N.m	ft-lb	N.m	ft-lb	N.m	ft-lb	Bolt size inch	Thread inch tpi	N.m	ft-lb	N.m	ft-lb	N.m	ft-lb
M5	0.8	4	3	6	4	9	7	1/4"	20	7	5	11	8	16	12
M6	1	6	4	10	7	15	11	1/4"	28	8	6	13	10	19	14
M8	1.25	16	12	25	18	36	27	5/16"	18	15	11	24	17	33	25
M8	1	17	13	26	19	38	28	5/16"	24	17	13	26	19	37	27
M10	1.5	31	23	48	35	71	52	3/8"	16	27	20	42	31	59	44
M10	1.25	33	24	51	38	75	55	3/8"	24	31	23	47	35	67	49
M10	1	35	26	53	39	78	58	7/16"	14	43	32	67	49	95	70
M12	1.75	54	40	84	62	123	91	7/16"	20	48	36	75	55	106	78
M12	1.5	56	41	87	64	128	94	1/2"	13	66	48	102	75	144	106
M12	1.25	59	44	90	66	133	98	1/2"	20	75	55	115	85	163	120
M14	2	84	62	133	98	195	144	9/16"	12	95	70	147	109	208	154
M14	1.5	94	69	142	105	209	154	9/16"	18	106	79	164	121	232	171
M16	2	131	97	206	152	302	223	5/8"	11	132	97	203	150	287	212
M16	1.5	141	104	218	161	320	236	5/8"	18	149	110	230	170	325	240
M18	2.5	181	133	295	218	421	310	3/4"	10	233	172	361	266	509	376
M18	2	196	145	311	229	443	327	3/4"	16	261	192	403	297	569	420
M18	1.5	203	150	327	241	465	343	7/8"	9	226	167	582	430	822	606
M20	2.5	256	189	415	306	592	437	7/8"	14	249	184	642	473	906	668
M20	1.5	288	212	454	335	646	476	1"	8	339	250	873	644	1232	909
M22	2.5	344	254	567	418	807	595	1"	12	371	273	955	704	1348	995
M22	1.5	381	281	613	452	873	644	1-1/8"	7	480	354	1077	794	1746	1288
M24	3	444	327	714	526	1017	750	1-1/8"	12	539	397	1208	891	1958	1445
M24	2	488	360	769	567	1095	808	1-1/4"	7	677	500	1519	1120	2463	1817
M27	3	656	484	1050	774	1496	1103	1-1/4"	12	750	553	1682	1241	2728	2012
M27	2	719	530	1119	825	1594	1176	1-3/8"	6	888	655	1992	1469	3230	2382
M30	3.5	906	668	1420	1047	2033	1499	1-3/8"	12	1011	746	2268	1673	3677	2712
M30	2	1000	738	1600	1180	2250	1659	1-1/2"	6	1179	869	2643	1949	4286	3161
M36	4	1534	1131	2482	1830	3535	2607	1-1/2"	12	1326	978	2974	2194	4823	3557

When using lock washers with nuts, increase torque values by 5%.

TABLE 2 - TURBO-HOP - TECHNICAL FEATURES

Pendular Spreader, for tractors up to 60 HP, PTO 540 rpm, 3 point hitch cat. 1 & 2.									
Model	HP	Hopper capacity cu. ft.	Carrying weight lbs.	Weight lbs.	Overall width	Overall length	Loading height	Spreading width ft.	Driveline 1 3/8"
303-600	20-60	20.6	1318	419	59"	68"	38"	17-47	ASAE cat. 1
303-800	20-60	30.3	1939	448	60"	68"	44"	17-47	ASAE cat. 1
303-999	20-60	36.1	2310	455	60"	68"	48"	17-47	ASAE cat. 1

5 - REPAIR PROCEDURES



CAUTION: All repair procedures must be done by authorized dealerships. It is not recommended that untrained individuals perform any repair work.

If cracks and scorings have occurred on the machine, brush them using a wire brush and touch up with primer and paint.

5.01 - Suggested Spare Parts

It is suggested that the following spare parts be kept on hand for the spreader at all times to prevent a minor problem from delaying work:

Description	Quantity
Deflector	1
Spout	1
Bronze slide	1

5.02 - Storage

After seasonal use it is important to perform the following for prolonged storage:

1. Empty hopper of product before unhooking it from the tractor.
2. Wash and dry the spreader carefully.
3. Inspect the spreader and replace worn or damaged parts. If corrosive material has eaten under the paint, clean off the area with a wire brush and touch up with primer and paint.
4. Tighten all hardware.
5. Grease or oil all areas indicated under Maintenance⁹.
6. Apply a thick layer of grease to all exposed moving parts.
7. Apply a film of biodegradable oil in crevices and corners.
8. Cover the spreader from the elements in order to have it in perfect condition for the start of the next season.
9. Make sure all parked machines are on a hard, level surface, and engage all safety devices.
10. Do not permit children to play on or around the stored unit.

Touch up paint available:	
Part #	Description
7300007	Primer, gray - aerosol spray can
7300010	Paint, Befco black - aerosol spray can

⁹ See Chapter 4 - Maintenance.

6 - TROUBLESHOOTING



WARNING: Be sure tractor engine is off, parking brake is locked, and key is removed before making any adjustments.

PROBLEM	POSSIBLE CAUSE	SOLUTION
Non uniform spread pattern.	Wrong gate opening.	Adjust gate opening.
	Spreader or pendular arm not positioned correctly.	Adjust spreader parallel to the ground with spout 28 inches above the ground level.
	Bronze slide worn inside gearbox.	Replace bronze slide.
Product not flowing to pendular arm.	Wet product.	Use dry product only or optional rubber insert.
	Powdered product.	Use optional agitator.
Narrow spread width.	Incorrect PTO speed.	Increase PTO speed to 540 PTO rpm.
	Pendular spout at wrong angle or wrong height.	Adjust spreader parallel to the ground with spout 28 inches above the ground level.

7 - PRE-DELIVERY CHECKLIST

To the dealer: Inspect the machine thoroughly after assembly to assure it is functioning properly before delivering it to the customer. The following checklist is a reminder of points to cover. Check off each item as it is found satisfactory or after proper adjustment is made.

- Gearbox oil level.
- Guards and shield properly fastened.
- Lubrication of grease fittings.
- All hardware properly tightened.
- All decals properly located and readable (**see fig. 2**).
- Overall condition (touch up scratches, clean and polish).
- Test run, check for excessive vibration or overheating of bearings.
- Operator's Manual.

Review the Operator's Manual with the customer. Explain the following:

- Warranty.
- Safe operation and service.
- Correct machine installation and operation.
- Daily and periodic lubrication, maintenance and inspections.
- Troubleshooting.
- Operational procedures and storage.
- Parts and service.
- Fill out the Pre-Delivery Checklist and Warranty Registration form.
- Give customer the Operator's Manual and encourage the customer to read the manual carefully.

IMPORTANT: Warranty is not valid unless Pre-Delivery Checklist and Warranty Registration form in Operator's Manual is completed in detail and mailed to the Company.

Model Number: _____

Serial Number: _____

Delivery Date: _____

Dealer's Signature: _____

8 - WARRANTY

BEFCO's responsibility will be limited to substitution of the acknowledged defective merchandise to the same place of delivery as the previous one was supplied.

1. LIMITED WARRANTY

BEFCO, Inc. herein referred to as the Company, warrants its machines and related accessories, hereafter referred to as the Machine, to be free from defects in material and workmanship, for a period of twelve (12) months from the date of invoice to the first registered owner; this limited warranty does not apply to common wear items and excludes belts, shear pins, oil, grease, tires, tubes, hydraulic hoses, knives and PTO shafts.

Labor will be reimbursed at \$40.00 per hour based on BEFCO's time schedule.

Cost of transport to the servicing dealer is the responsibility of the customer.

Warranty coverage shall not be transferable from the first owner to any subsequent owner.

2. DISCLAIMER OF ALL OTHER WARRANTIES AND REMEDIES

Neither the Company nor any company affiliated with the Company makes any warranties, representations or promises, expressed or implied, as to the quality, performance or application of its products other than those set forth herein and does not make any implied warranty of merchantability or fitness.

The only remedies the purchaser has in connection with the breach, or performance of any warranty on the Company's Machine are those set forth herein. In no event will the dealer, the Company, or any company affiliated with the Company, be liable for:

- a. Injuries or damages of any kind or nature, direct, consequential or contingent to person or property.
- b. Any expenses incurred by the owner to repair, replace or rework any allegedly defective item.
- c. Any loss, cost, forfeiture or damages (including loss of profits; loss of crops; loss because of delay in field operations; any expenses or loss incurred for labor, supplies, substitute machine rental; liabilities of the owner to its customers or third persons; and all other consequential damages, losses, liabilities or damages for any other reasons) whether direct or indirect, and whether or not resulting from or contributed to by the default or negligence of the Company, its agents, employees and subcontractors which might be claimed as a result of the use or failure of the equipment delivered.

The Company's liability based on this limited warranty or any other applicable laws shall be limited to replacement or refund of the purchase price of the product.

The limited warranty extended herein gives you specific rights and you may also have other rights which vary from state to state. Neither the dealer nor the Company personnel has the authority to make any representation or to modify the terms and limitations of this warranty in any way.

Other than the limited warranty extended hereby there is no other expressed warranty in connection with the design, safety or use of any of the Company's products except as to title. All implied warranties are expressly disclaimed pursuant to the terms of this warranty.

3. CUSTOM WORK

If the Machine is used for commercial purposes such as custom work, the period warranted for the Machine is limited to six (6) months from the date of delivery to the first registered owner and does not cover any labor charges incurred.

4. RENTAL

If the Machine is used for rental purposes the period warranted for the Machine is limited to thirty (30) days from the date of delivery to the first registered owner and does not cover any labor charges incurred.

5. REGISTRATION

In order to qualify for coverage on this limited warranty, the product and name of the original purchaser must be registered with the Company by a completed Machine Pre-Delivery Checklist and Warranty Registration along with a copy of the dealer's invoice to the first registered owner to the Company within fourteen (14) days after the date of delivery to the original purchaser.

6. WARRANTY SERVICE

Warranty Service must be performed by a dealer authorized by BEFCO. If the warranty service requested is approved, the owner shall pay only for labor beyond the rate allowed, for overtime labor, and for any mileage charge for transporting the equipment to and from the dealer's shop. It is assumed that the dealer has the appropriate general and special tools to service the machine. Time required for replacement of knives, oil, grease and to remove excessive dirt from the Machine is not subject to reimbursement by the Company. The owner is required to clean the Machine before presenting it to the dealer for service work. The Machine must be delivered within thirty (30) days after failure date by the owner to the dealer to be eligible for warranty consideration.

7. UNAPPROVED SERVICE OR MODIFICATION

All obligations of the Company under this limited warranty shall be terminated if:

- a. Proper service and operation instructions as outlined in the Operator's Manual and on the instruction sticker on the Machine, are not followed.
- b. The Machine is modified or altered in any way not approved by the Company.
- c. The Company does not receive a copy of the dealer's invoice to the first registered owner within fourteen (14) days from the date of delivery.
- d. The Company has not been paid in full, by the dealer, for the Machine.

8. ACCIDENTS AND NORMAL MAINTENANCE

This limited warranty covers defective material and workmanship. It does not cover depreciation or damage caused by normal wear, accidents, improper maintenance, improper protection or improper use. The costs of normal maintenance or repairs for accidents or improper use, and related labor will be borne by the owner.

9. REPLACEMENT PARTS

BEFCO, Inc. warrants replacement parts to be free from defect in material and workmanship for a period of thirty (30) days from the date of delivery to the original purchaser.

WARRANTY REGISTRATION

BEFCO, Inc.
P.O. Box 6036
Rocky Mount, NC 27802-6036

Tel: (252) 977.9920 - Fax: (252) 977.9718

Dealer _____ Acct. # _____	Retail Customer _____
Street _____ Country _____	Street _____
Town _____ State _____ Zip _____	Town _____ State _____ Zip _____
Date of delivery _____ Invoice # _____	Phone _____
Model # _____ Serial # _____	
<p>Pre-Delivery Checklist:</p> <p><input type="checkbox"/> Oil in gearbox.</p> <p><input type="checkbox"/> Greased fittings.</p> <p><input type="checkbox"/> Safety guards in place.</p> <p><input type="checkbox"/> All hardware tight.</p> <p><input type="checkbox"/> Bolts torqued correctly.</p> <p><input type="checkbox"/> Attached unit to tractor. Yes/No.</p> <p><input type="checkbox"/> Field adjusted. Yes/No.</p> <p><input type="checkbox"/> Test run. Dry/Infield.</p> <p><input type="checkbox"/> Safety decals.</p> <p><input type="checkbox"/> Operator's Manual.</p> <p>The machine described above, has been prepared for delivery according to the Pre-Delivery Checklist and the Customer has been instructed in its care and operation and the condition of warranty.</p>	<p>Tractor make: _____</p> <p>Model: _____; HP _____</p> <p>Type of operation: Private homeowner, Landscaping, Commercial maintenance, Golf Course, Municipality, Turf Farm, others: _____</p> <p>Approximate number of acres machine will be used on annually: _____</p> <p>I hereby acknowledge that: I have received and accepted delivery of the machine described. The equipment was checked thoroughly for loose or missing parts and has been adjusted in accordance with the Pre-Delivery Checklist. I have read and understand the nature and extent of the warranty and understand clearly that there were and are no other representations of warranties either expressed or implied, made by anyone. I have been advised on proper operation, maintenance and lubrication procedure of this equipment. I have been instructed on and do understand the application, limitation and capacities this equipment was designed and recommended for, all as described in the Operator's Manual and literature published by the Company.</p>
Inspected by: _____	
Date: _____	Date: _____
Dealer's Signature: _____	Customer's Signature: _____

This registration along with a copy of the invoice must be sent to BEFCO, Inc. within 14 days of date of purchase.

Sender:

Fold here

*Place stamp
here*

BEFCO, Inc.

Warranty Department

P.O. Box 6036

Rocky Mount, NC 27802-6036

Cut along this line

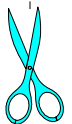

Use only original spare parts

All rights reserved. It is unlawful to copy, reprint or use any of the information or details in this manual without the expressed written permission of the Company. Technical information provided in this manual is approximate, the Company reserves the right to modify or improve the models shown for technical or commercial purposes. Pictures in this manual do not necessarily show the machine as delivered.

BEFCO[®]

P.O. Box 6036
Rocky Mount, NC 27802-6036
Tel.: 252.977.9920 - Fax: 252.977.9718
www.befco.com

