

BEFCO[®]

Operator's Manual

CYCLONE

Engine Driven Grooming Mower

C30-CE5H

(serial #345293 & above)

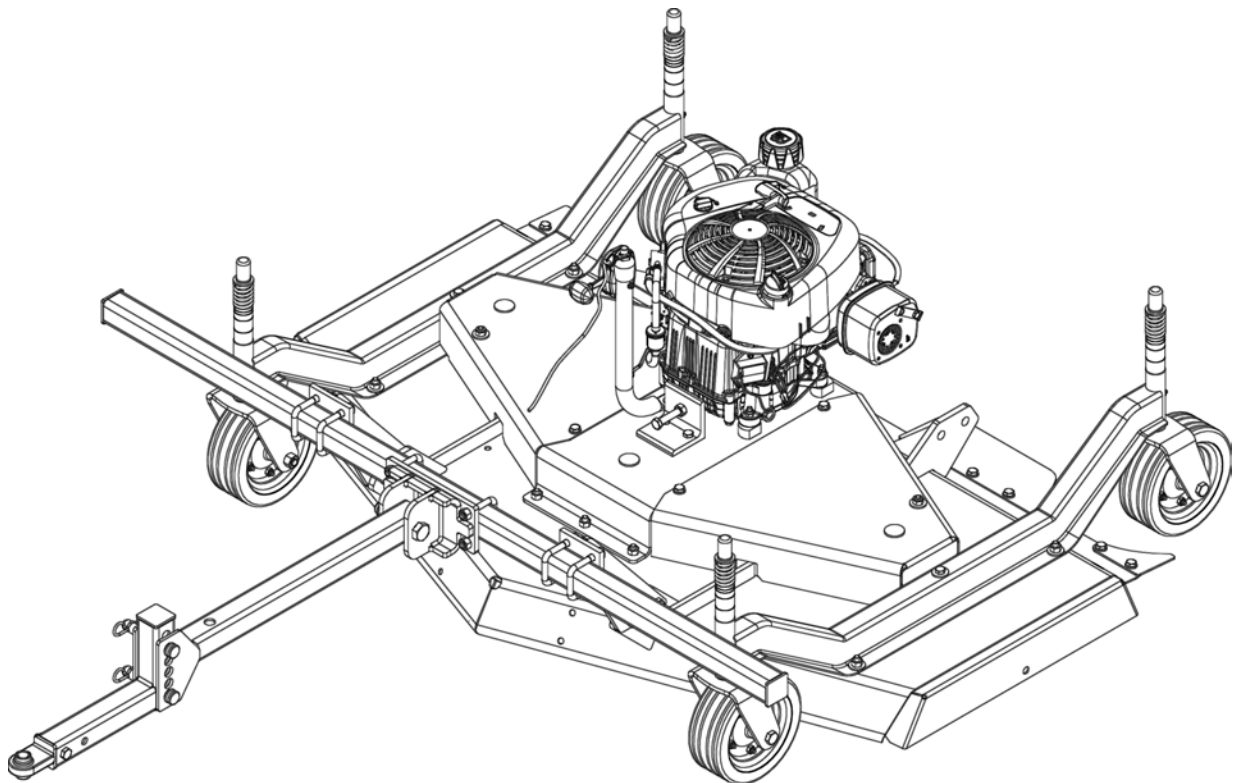

The operator's manual is a technical service guide and must always accompany the machine.

Manual 960-395B
September 2025

SAFETY

Take note! This safety alert symbol found throughout this manual is used to call your attention to instructions involving your personal safety and the safety of others. Failure to follow these instructions can result in injury or death.



*This symbol means:
ATTENTION!
BECOME ALERT!
YOUR SAFETY IS INVOLVED!*

Signal Words

Note the use of the signal words DANGER, WARNING and CAUTION with the safety messages. The appropriate signal words for each have been selected using the following guidelines:



DANGER: Indicates an imminently hazardous situation that, if not avoided, will result in death or serious injury.



WARNING: Indicates a potentially hazardous situation that, if not avoided, could result in death or serious injury, and includes hazards that are exposed when guards are removed. It may also be used to alert against unsafe practices.



CAUTION: Indicates a potentially hazardous situation that, if not avoided, may result in minor or moderate injury.

INDEX

1 - GENERAL INFORMATION	4
1.01 - General	4
1.02 - Warranty Information	4
1.03 - Model and Serial Number ID	5
2 - SAFETY PRECAUTIONS	6
2.01 - Preparation	6
2.02 - Starting and Stopping	7
2.03 - Messages and Signs	7
3 - OPERATION	9
3.01 - Operational Safety	9
3.02 - Set Up	11
3.03 - Assembly Instructions	11
3.04 - Cutting Height Adjustment	13
3.05 - Pre-Operational Check	15
3.06 - Attaching to the Vehicle	15
3.07 - Offsetting the Mower	17
3.08 - Start Up	18
3.09 - Working Speed	19
3.10 - Operating Techniques	20
3.11 - Uneven Terrain	21
3.12 - Transport	22
4 - MAINTENANCE	23
4.01 - Maintenance Safety	23
4.02 - Service	24
4.03 - Blade Maintenance	25
4.04 - Belt Tension	27
4.05 - Belts Replacement	29
5 - REPAIR PROCEDURES	32
5.01 - Blade Spindle	32
5.02 - Suggested Spare Parts	32
5.03 - Storage	32
6 - TROUBLESHOOTING	33
7 - PRE-DELIVERY CHECKLIST	35
8 - WARRANTY	36
PARTS MANUAL	41

1 - GENERAL INFORMATION

Thank you and congratulations for having chosen our implement. Your new grooming mower is a technologically advanced machine constructed of high quality, sturdy components that will fulfill your working expectations. Read this manual carefully. It will instruct you on how to operate and service your mower safely and correctly. Failure to do so could result in personal injury and/or in equipment damage.

1.01 - General



CAUTION: Unless otherwise specified, all hardware is metric. Use only metric tools on metric hardware. Other tools that do not fit properly can slip and cause injury.



CAUTION: Right hand and left hand sides of the implement are determined by facing in the direction the implement will travel when going forward (see fig. 2).

1.02 - Warranty Information

Carefully read the Warranty section¹, detailing coverage and limitations of this warranty. **Warranty** is provided for customers who operate and maintain their equipment as described in this manual. Warranty registration is accomplished by the dealer by completing and forwarding the **Warranty Registration** form to the Company, along with a copy of the dealer's invoice. It is in your best interest to insure that this has been done.

Warranty does not cover the following:

1. Cleaning, transporting, mailing and service call charges.
2. Engine.
3. Normal wear items such as belts, blades, bearings, etc.
4. Depreciation or damage caused by normal wear, accidents, improper maintenance, improper protection or improper use.
5. The use of non-original spare parts and accessories.

¹ See Chapter 8 - Warranty.

Your Authorized Company Dealer has genuine parts in stock. Only these approved replacement parts should be used.

This limited warranty covers defective material and workmanship. The cost of normal maintenance or repairs for accidents or improper use and related labor will be borne by the owner.

NOTE: Engine warranty, service and parts must be obtained through an authorized service center for Briggs & Stratton engines.

1.03 - Model and Serial Number ID

Attached to the frame is an ID plate showing the model and the serial number. Record your implement model and serial number in the space provided below. Your dealer needs this information to give you prompt, efficient service when you order parts.

BEFCO	1781 S. Wesleyan Blvd. – P.O. Box 6036 Rocky Mount, N.C. 27802 – U.S.A. Tel: 1.252.977.9920 Fax: 1.252.977.9718
MODEL:	
SERIAL:	
VERSION:	

2 - SAFETY PRECAUTIONS

Safety is the primary concern in the design and manufacture of our products. Unfortunately our efforts to provide safe equipment can be wiped out by a single careless act of an operator.

In addition to the design and configuration of equipment, hazard control and accident prevention are dependent upon the awareness, concern, prudence and proper training of personnel involved in the operation, transport, maintenance and storage of equipment. It is the operator's responsibility to read and understand all safety and operating instructions in the manual and to follow these.

Allow only properly trained personnel to operate the mower. Working with unfamiliar equipment can lead to careless injuries. Read this manual, the engine manual and the manual for your tractor, before assembly or operation, to acquaint yourself with the machines. It is the mower owner's responsibility, if this machine is used by any person other than yourself, is loaned or rented, to make certain that the operator, prior to operating, reads and understands the operator's manuals and is instructed in safe and proper use.

2.01 - Preparation



1. Before operating equipment read and understand the operator's manual and the safety signs (**see fig. 2**).
2. Thoroughly inspect the implement before initial operation to assure that all packaging materials, i.e. wires, bands, and tape have been removed.
3. Personal protection equipment including hard hat, safety glasses, safety shoes, and gloves are recommended during assembly, installation, operation, adjustment, maintaining and/or repairing the implement.
4. Operate the mower only with a towing vehicle equipped with an approved Roll-Over-Protective-System (ROPS). Always wear your seat belt. Serious injury or even death could result from falling off the vehicle.
5. Clear area to be cut of stones, branches or other debris that might be thrown, causing injury or damage.
6. Operate only in daylight or good artificial light.
7. Ensure mower is properly mounted, adjusted and in good operating condition.
8. Ensure that all safety shielding and safety signs are properly installed and in good condition.
9. Use only approved drawbar hitch points.
10. Handle gasoline with care, it is highly flammable. Use only approved gasoline containers.
11. Never remove fuel cap or add gasoline to a running engine or a hot engine. Never fill the fuel tank indoors. If spilling occurs wipe up immediately.

12. To reduce fire hazard, keep engine free of grass, leaves or excessive grease.
13. Do not change the engine governor settings or over-speed the engine.

2.02 - Starting and Stopping



1. Be sure that no one is near the machine prior to engaging or while the machine is working.
2. Be sure the towing vehicle is in "Neutral" before starting engine.
3. Mower operating power is supplied from mower engine. Refer to your engine manual for engagement and disengagement instructions. Know how to stop the towing vehicle and mower quickly in case of an emergency.
4. Open doors if engine is running in the garage; exhaust fumes are dangerous. Do not run engine indoors.
5. After striking an obstacle, stop mower engine, remove the wire from the spark plug, shut the towing vehicle down and thoroughly inspect for damage before restarting.
6. Do not operate if mower vibrates excessively. Excessive vibration is an indication of damage.
7. Stop mower engine before backing up. Do not cut in reverse. Carefully observe area behind mower before backing up.
8. Stop mower engine and watch out for traffic when crossing gravel drives, walks or roads.
9. Stop mower engine, towing vehicle engine and set parking brake before leaving operator's position.
10. Stop mower engine, towing vehicle engine, disconnect spark plug wire, set parking brake and wait for all movement to stop before making any repairs or adjustments.
11. Never adjust cutting height or leveling linkage while the engine is running.
12. Stop mower engine when transporting or not in use.
13. When leaving towing vehicle unattended, set parking brake, stop both engines and remove key.
14. Never store the equipment with gasoline in the tank inside a building where fumes may reach an open flame or spark. Allow engine to cool before storing in any enclosure.

2.03 - Messages and Signs



1. Read and adhere to all safety and operating decals on this machine (**see fig. 2**).
2. Before dismounting towing vehicle: allow moving parts to stop, stop both engines, set brake and remove the key of unattended equipment.
3. Keep away from rotating blades.
4. Keep guards and shields in place and in good condition.

5. Do not mow with bystanders in area.
6. Allow no riders on towing vehicle or mower.
7. Allow moving parts to stop before repair.
8. Securely support mower before working underneath.

Additional warning and operating decals are available at no extra charge. Please specify model and serial number when ordering.

Fig. 2 - Safety decals - implement; replace immediately if damaged.

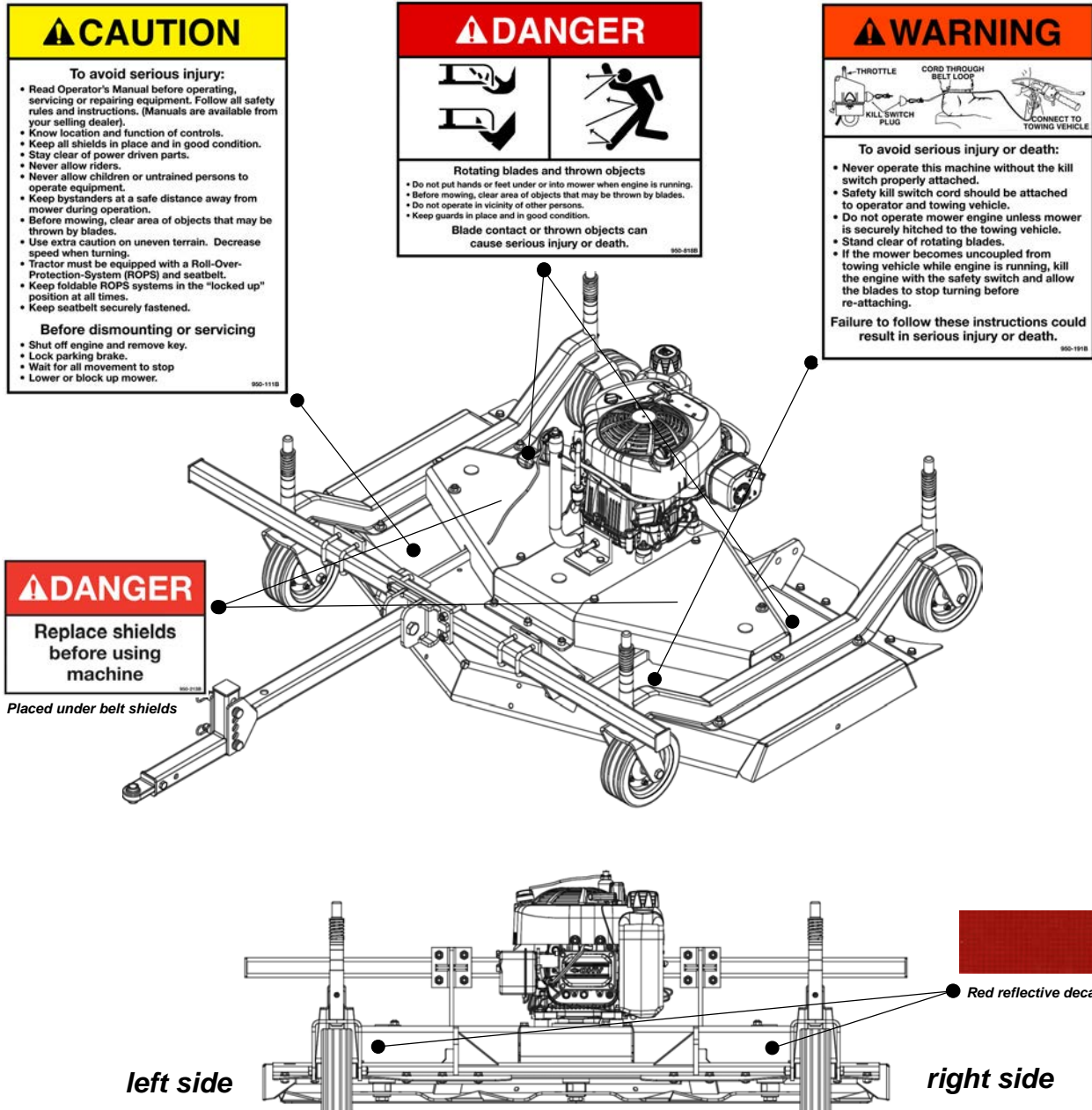

3 - OPERATION

Congratulations on your purchase of a C30-CE5H engine driven 5' three spindle mower! The C30-CE5H is the ideal unit to use for mowing large private lawns, industrial parks, hospital grounds, schools, highways, golf courses or any type of sports complexes and can be used either as your primary mower or as an extension to you current lawn tractor's mower deck. This mower was designed to be either front or rear tractor mounted. When the unit is being towed, it attaches to the towing vehicle using a category 1 ball hitch and pin. When the unit is being pushed, it attaches to the front of the vehicle using a standard 2" receiver hitch. The hitch design also allows the mower to be offset left or right up to 75".

The C30-CE5H is equipped with a powerful 11.5 HP Briggs & Stratton Intek gasoline engine with a centrifugal clutch. The centrifugal clutch is attached to the vertical shaft of the engine, which, through the belts, transmits drive to the pulleys, the spindle shafts and the blades. A safety kill switch is supplied to allow the engine to shut off in case the operator is thrown off the driver's seat.

Mowers are equipped with 4 wheels to provide a stable and level cutting height even in undulating ground conditions. The cutting height ranges from a minimum of 1" to a maximum of 4" and is adjusted by adding or removing spacers to each wheel.

3.01 - Operational Safety



CAUTION: Our mowers are designed considering safety as the most important aspect and are the safest available in today's market. Unfortunately, human carelessness can override the safety features built into our machines. Injury prevention and work safety, aside from the features on our mowers, are very much due to the responsible use of the equipment. It must always be operated prudently following with great care, the safety instructions laid out in this manual.



1. The use of this equipment is subject to certain hazards which cannot be prevented by mechanical means or product design. All operators of this equipment must read and understand this entire manual and the engine manual, paying particular attention to safety and operating instructions, prior to using.
2. Do not operate the towing vehicle and mower when you are tired, sick or when using medication.
3. Keep all helpers and bystanders at least 300 feet from a rotary mower. Only properly trained people should operate this machine.
4. The majority of accidents involve injury of bystanders by objects thrown by the rotating blades, and operators being knocked off the towing vehicle by low hanging

limbs and then being run over by the mower. Accidents are most likely to occur with machines that are loaned or rented to someone who has not read the operator's manual and is not familiar with a rotary mower.

5. Test the safety kill switch on the mower to ensure that the mower will cut off when key is removed.
6. Before operating, attach the kill switch rope to the operator's belt strap and to the towing vehicle on the front of operator's seat.
7. Always stop the towing vehicle, set brake, shut off both the mower engine and the towing vehicle engine, remove the ignition key and allow mower blades to come to a complete stop before dismounting towing vehicle. Never leave equipment unattended with the towing vehicle running.
8. Never place hands or feet under mower with engine running or before you are sure all motion has stopped. Stay clear of all moving parts.
9. Do not allow riders on the mower or towing vehicle at any time. There is no safe place for riders.
10. Do not operate unless all personnel, livestock and pets are at least 300 feet away to prevent injury by thrown objects.
11. Before backing up, turn off mower engine and look behind carefully.
12. Install and secure all guards and shields before starting or operating.
13. Keep hands, feet, hair and clothing away from moving parts.
14. This rotary mower is designed for use with all terrain vehicles (ATVs) or garden tractors.
15. Never operate towing vehicle and mower under trees with low hanging limbs. Operators can be knocked off the towing vehicle and then run over by the rotating blades.
16. The rotating parts of this machine have been designed and tested for rugged use. However, they could fail upon impact with heavy, solid objects such as steel guard rails and concrete abutments. Such impact could cause the broken objects to be thrown outward at very high velocities. To reduce the possibility of property damage, serious injury, or even death, never allow the cutting blades to contact such obstacles.
17. Frequently check mower blades. They should be sharp, free of nicks and cracks and securely fastened.
18. Stop mower immediately upon striking an obstruction. Turn mower engine off, turn towing vehicle engine off, remove key, disconnect spark plug wire, set towing vehicle brake and wait for all movement to stop. Inspect and repair any damage before resuming operation.
19. Stay alert for holes, rocks and roots in the terrain and other hidden hazards. Keep away from drop-offs.
20. Use extreme care and maintain minimum ground speed when transporting on hillside, over rough ground and when operating close to ditches or fences. Be careful when turning sharp corners.
21. Reduce speed on slopes and sharp turns to minimize tipping or loss of control. Be careful when changing directions on slopes. Do not start or stop suddenly on slopes. Avoid operation on steep slopes.
22. When making tight turns, do not allow pull hitch to ride up on towing vehicle tires.

23. Inspect the entire machine periodically². Look for loose fasteners, worn or broken parts, and leaky or loose fittings.
24. Pass diagonally through sharp dips and avoid sharp drops to prevent "hanging up" towing vehicle and mower.
25. Avoid sudden starts and stops while traveling up or downhill.
26. Always cut down slopes; never across the face. Avoid operation on steep slopes. Slow down on sharp turns and slopes to prevent tipping and/or loss of control.

3.02 - Set Up

Notice to dealer: Pre-delivery setup and service including lubrication is the responsibility of the authorized dealer. It is up to him to assure that the machine is in perfect condition and ready to be used. It is his responsibility to ensure that the customer is aware of all safety aspects and operational procedures for the mower and the engine. He must also fill out the Pre-Delivery Checklist³ prior to delivering the mower.



CAUTION: Stand clear of bands when cutting as they could be under sufficient tension to cause them to fly loose. Take care in removing bands and wire, they often have extremely sharp edges and cut very easily.

3.03 - Assembly Instructions

C30-CE5H mowers are shipped almost completely assembled. Follow the instructions below to assemble remaining items on the mower (**see fig. 3**).



CAUTION: Engine is shipped without oil. Fill oil reservoir to the correct level before starting the engine. See the engine manufacturer's operator's manual for further information on engine.

To assemble the C30-CE5H mower to the rear of the towing unit proceed as follows:

1. Using a crow bar open the top of the crate then remove the sides of the crate.
2. Add oil to the engine. Use the dip stick to fill to the correct level.
3. Make sure the drawbar attachment bracket slightly swivels between the 4 nuts that secure it to the offset bar.
4. Position the drawbar inside the drawbar attachment bracket and secure it in place using the M20 bolt and nut.

² See Chapter 4 - Maintenance.

³ See Chapter 7 - Pre-Delivery Checklist.

- Secure the hitch bracket to the drawbar using two Ø19 pins and two Ø4 cotter pins. Ball joint will arrive already assembled to hitch bracket.

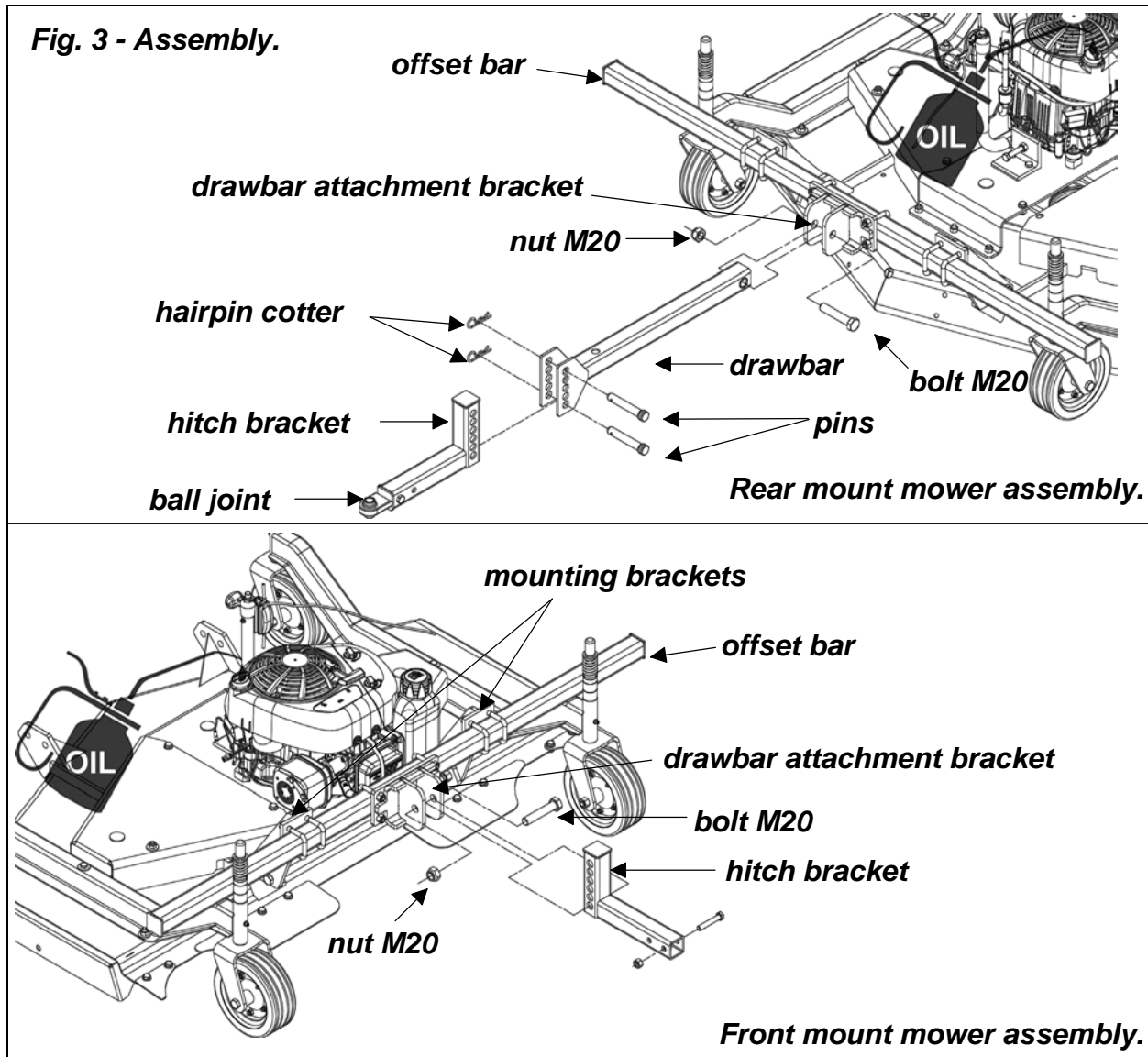

To assemble the C30-CE5H mower to the front of the ATV/UTV proceed as follows:

- Move the mounting brackets that hold the offset bar and assemble them to the rear of the mower.
- Make sure the drawbar attachment bracket slightly swivels between the 4 nuts that secure it to the offset bar.
- Position the hitch bracket inside the drawbar attachment bracket and secure it in place using the M20 bolt and nut. Use the hole that will allow you to keep the drawbar attachment bracket as level as possible when attached to the ATV/UTV.

4. Remove the ball joint from the hitch bracket and use the bolt and nut to secure it to the 2" receiver of the ATV/UTV.

Note: All hardware needed for assembly will be found on the machine. Assembly will be easier if all parts are loosely assembled before tightening the hardware.

3.04 - Cutting Height Adjustment



WARNING: Keep hands and feet away from moving blades.

Be sure both towing vehicle engine and mower engine are off, spark plug wire is disconnected, parking brake is locked, and key is removed before making any adjustments.

Before working under mower install blocks under the deck to prevent it from falling.

The cutting height is the distance from the blades to the ground. The cutting height is adjusted by **moving the spacers on the wheel yokes**. Placing spacers between the wheel arm and the wheel yoke raises the cutting height by the size of the spacer. Removing the spacers lowers it by the same height (**see fig. 4**).

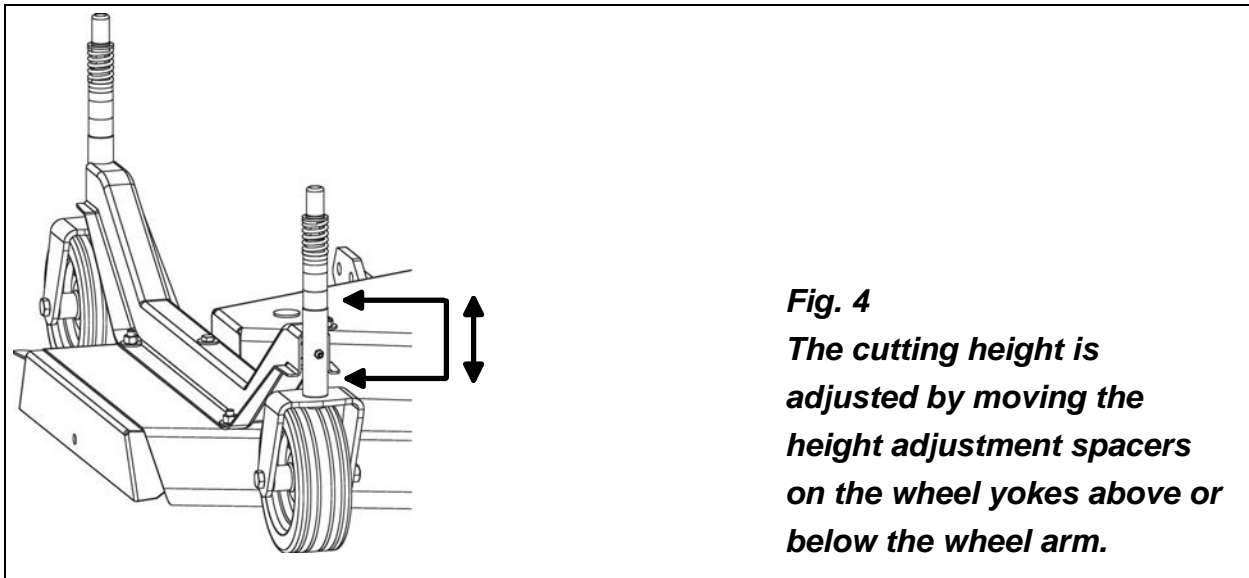

Fig. 4
The cutting height is adjusted by moving the height adjustment spacers on the wheel yokes above or below the wheel arm.

The cutting height is adjustable from 1" to 4". All mowers are supplied spacers of 1/4", 1/2", and 1" heights to allow operator to obtain the desired cutting height. When there are no spacers between the bottom of the wheel arm and the top of the wheel yoke the mower will cut at approximately 1". Be sure all wheel arms are adjusted equally. This is the only way to ensure a completely uniform cut. Cutting lower than 2" under most circumstances should be avoided.

IMPORTANT: Very low cutting heights should be avoided. Damaging shock loads occur when the blades strike the ground repeatedly. This can cause damage to the mower.

To adjust cutting height do the following:

1. Place mower on a level surface.
2. Turn off engine and set parking break of vehicle.
3. Turn off engine on mower.
4. Disconnect the drawbar from the mower and disconnect the hitch bracket from the drawbar.
5. Secure the drawbar to the supplied height adjustment stand using a Ø19 pin and Ø4 cotter pin (**see fig. 5**).
6. Place the height adjustment stand to the side of the mower and position the "U" shaped tip of the stand to straddle the side of the deck (**see fig. 6**).
7. Using the weight of your body, push the drawbar down towards the ground. This will cause the side of the deck to be raised off the ground.
8. Once raised off the ground, secure the mower with blocks underneath it to prevent it from falling. Do not rely on mower lifting tool alone to keep the mower raised off the ground.
9. Remove the plastic cap and the M12 nuts from the wheel yokes that are raised from the ground.
10. Remove the spring and washer on top of the yoke, add spacers below the wheel arm to increase cutting height, or on top of the wheel arm to reduce the cutting height.
11. Reassemble yokes to wheel arm, replace spring and washer and secure them with M12 nut. Replace plastic caps.
12. Remove blocks and slowly raise drawbar off the ground to lower down the mower deck.
13. Repeat steps 6 through 12 on other side of the mower deck.
14. Verify that all wheels are set at the same height.
15. Disconnect drawbar from the height adjustment stand.
16. Reassemble hitch bracket to the drawbar using two Ø19 pins and two Ø4 cotter pins.
17. Secure the drawbar to the mower using the remaining Ø19 pin and Ø4 cotter pin.

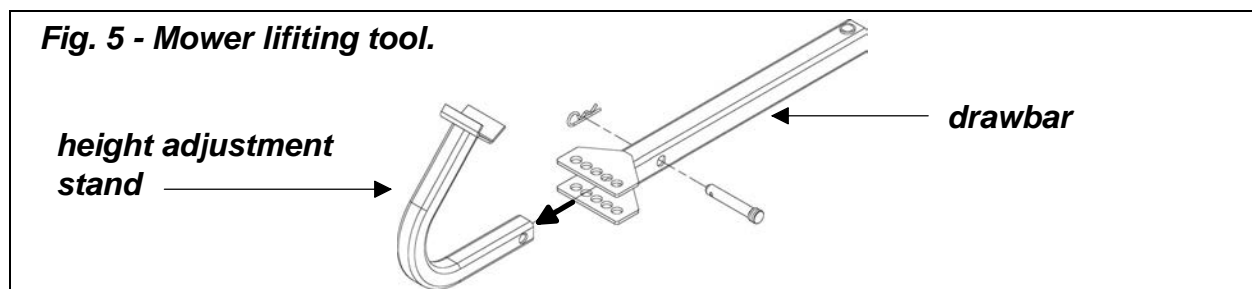

Each C30-CE5H is supplied standard with the necessary tools to raise the deck (**see fig. 5**). The height adjustment stand connected to the drawbar will allow you to raise

one side of the deck at a time to adjust the wheels to the desired cutting height (see fig. 6).

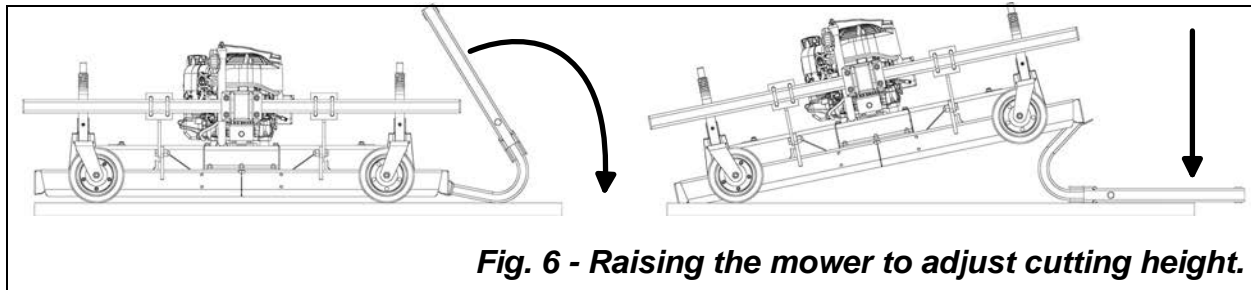

3.05 - Pre-Operational Check

IMPORTANT: Check each of the following, carefully, prior to engaging the equipment:

1. The spindle bearings have been greased.
2. The belts for proper tension.
3. No wrappings or foreign objects are around the blades or belts.
4. The blades are properly installed and the blade bolts properly torqued⁴.
5. All hardware is tight.
6. All safety shields and guards are in place and tightly attached.
7. No people or animals are in the work area.



WARNING: Shut off mower engine and remove spark plug wire from spark plug before making adjustments, servicing or cleaning the machine. Failure to do so could result in accidental starting of engine causing possible injury or death.

3.06 - Attaching to the Vehicle

The hitch on the C30-CE5H allows the mower to be set up to be either towed behind the vehicle or pushed in front of the vehicle.

To attach the mower to be towed behind the tractor do the following:

1. Back the towing vehicle up to the mower.
2. Turn off engine and set parking break of vehicle.
3. Attach a category 1 hitch pin to towing vehicle drawbar.
4. Slide a rubber washer and mower swivel hitch on the hitch pin and secure with a lynch pin. Make sure hitch pin goes completely through each piece and is secured to prevent accidental separation.
5. Tighten the spring loaded nuts on the front wheels of the mower to help the unit track behind the tractor correctly. Set for the back wheels to have some pivot to help the mower turn with the tractor (see fig. 9).

⁴ See Table 1, page 30.

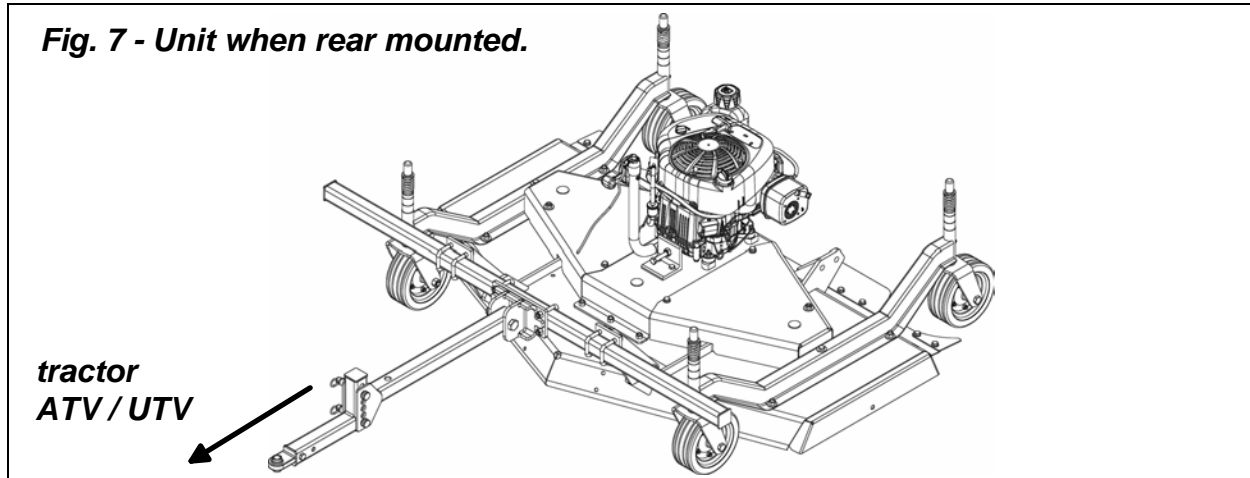
Fig. 7 - Unit when rear mounted.**To attach the mower to be pushed in front of the ATV/UTV do the following:**

1. Secure the 2" receiver bracket to the front hitch of the ATV/UTV using the supplied bolt. Tightening the bolt will remove any slack between the male and female part of the receiver. This will allow for the mower to track better and remove any slack that can be noticed when turning.
2. Turn off engine and set parking break of vehicle.
3. With the hitch installed, drive the ATV/UTV behind the mower and secure the hitch using the M20 bolt and nut. Leave sufficient slack to allow mower to float independently from ATV/UTV.
4. Loosen the spring loaded nuts to set all four wheels on the mower to have a little room to pivot, this will allow the mower to turn in the direction that the ATV/UTV is turning (**see fig. 9**). If you loosen the nuts excessively, the mower will have a tendency to swing side to side. If on the other hand you tighten the spring loaded nuts excessively, the wheels will not turn properly in the direction that the ATV/UTV is turning.

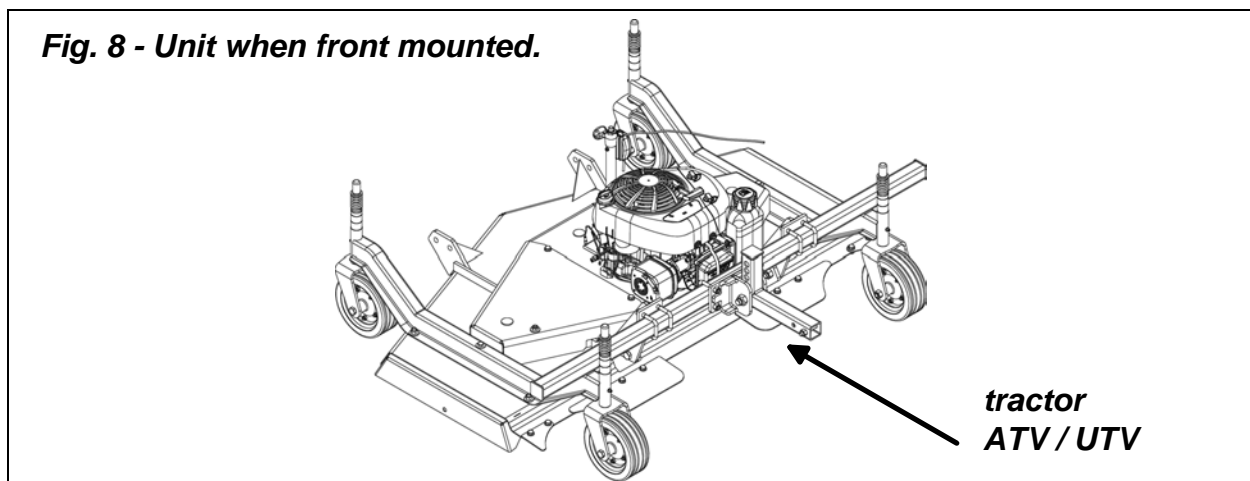
Fig. 8 - Unit when front mounted.

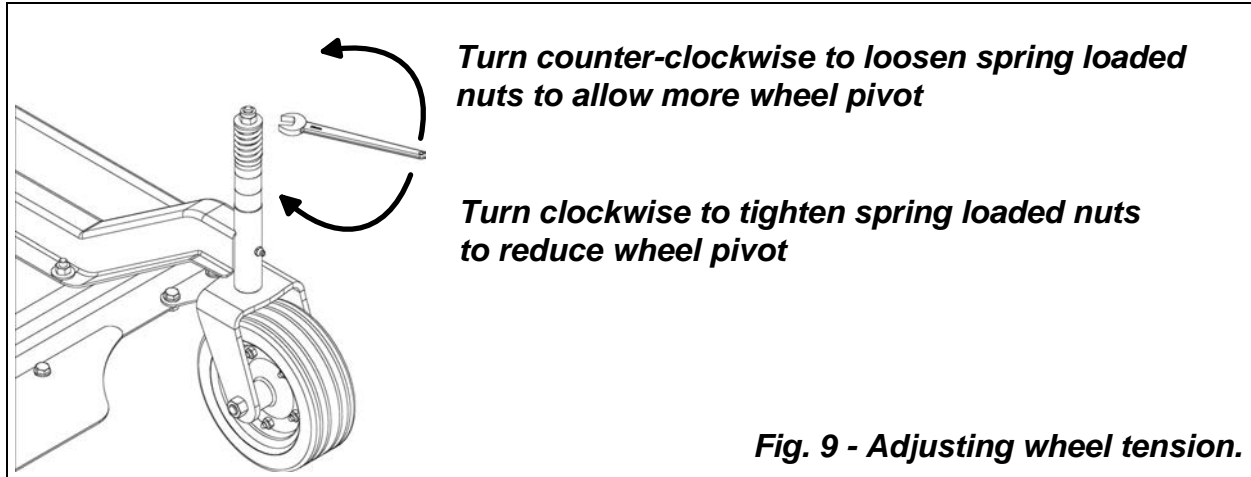

Fig. 9 - Adjusting wheel tension.



CAUTION: Towing vehicle front end stability is necessary for safe operation when pulling equipment.



CAUTION: Always ensure that the towing vehicle's tire pressure is correct according to the vehicle's operator's manual.



DANGER: Failure to ensure a secure hitching of the implement to the towing vehicle can cause serious injury or death.

3.07 - Offsetting the Mower

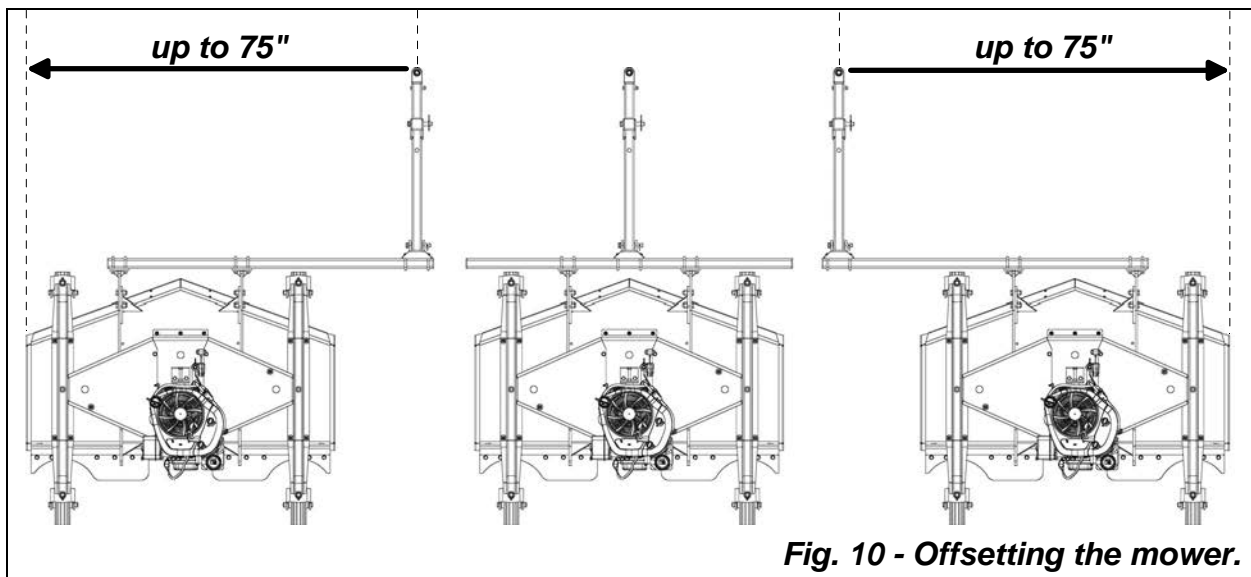

Fig. 10 - Offsetting the mower.

The hitch on the C30-CE5H allows for the mower to be set up to be offset up to 75" to the left or right side of the tractor. In certain cases, operators like to offset the mower because it allows them to increase the mowing width of their belly mounted mower. In other cases, offsetting the mower allows the operator to safely mow closer to obstacles (for example, near the edge of a pond or under trees).

To offset the mower do the following:

1. Loosen the nuts that secure the "U" bolts to the offset bar.
2. Position the mower and the offset bar in the desired position to the left or right of the tractor.
3. Secure the nuts back on the "U" bolts.

3.08 - Start Up

Before starting to mow, never forget that the **operator is responsible** for the following:

1. Safe and correct driving of the towing vehicle and mower.
2. To learn precise safe operating procedures for both the towing vehicle and the mower.
3. To ensure all maintenance and lubrication has been performed on the mower.
4. To have read and understood all safety aspects for the mower and the engine in the respective operator's manuals.
5. To have read and understood all safety decals on the mower.
6. Checking the condition of the blades. Worn or damaged blades should be changed before starting⁵.
7. Checking to ensure that the cutting edge is the leading edge of the blade⁶.
8. Checking that there is no wire, weed, grass or other material wrapped around blades.
9. Checking the towing vehicle tires for the proper pressure in accordance with the tractor operator's manual.
10. Making sure the proper attire is worn. Avoiding loose fitting clothing which can become entangled. Wearing sturdy, tough-soled work shoes and protective equipment for eyes, hands, ears and head. Never operate mower in bare feet, sandals or sneakers.
11. Checking area for stones, branches and other debris that might be thrown.
12. Ensuring proper lighting is available, sunlight or good artificial lighting.
13. Ensuring the kill switch safety is properly attached.

To **start mower engine** do the following:

1. Install the kill switch plug.
2. Open the fuel valve.
3. Push throttle in the "CHOKE" position. If the engine is warm, place the throttle in "SLOW" position.
4. Place one foot on the mower deck and one foot firmly anchored on ground. Make sure foot on ground does not get underneath mower. Pull starter cord briskly returning slowly until engine starts.

⁵ See Section 4.03 - Blade Maintenance.

⁶ See Section 4.03 - Blade Maintenance.

5. When engine cranks, slow to idle and allow the engine to warm up for several minutes. When engine is warm adjust throttle to desired speed.

NOTE: If engine is hard to crank consult the engine manufacturer's operator's manual.



DANGER: Keep hands and feet away from underneath the mower. When starting the engine place one foot on the mower deck and one foot firmly anchored to the ground safely away from underneath the mower deck.

To **start cutting** ensure that:

1. The kill switch tether cord is connected from the switch through the operator's belt loop to towing vehicle forward of operator's seat.
2. Parking brake is released.
3. The lowest gear is selected in order to begin cutting at a slow speed. Adjust speed gradually in relation to the condition of the ground.



DANGER: Ensure that the safety kill switch is working properly. Test to make sure that the mower will cut off when the switch is removed. Never operate the mower without the safety kill switch properly attached. Failure to do so could cause serious injury or death.

To **shut down mower engine** do the following:

1. Idle the engine down.
2. Set parking brake.
3. Pull out kill switch plug.
4. Stop the engine of the towing vehicle.
5. Close fuel valve.
6. Allow the mower blades to come to a complete stop before dismounting.

3.09 - Working Speed

The mowing speed depends on ground conditions, mowing height, and grass thickness. Only a test run will enable you to gauge the optimal working speed for your conditions.

Under most conditions a 3 to 5 mph ground speed is best. As a rule of thumb, and if the conditions permit, grass dispersion is increased by higher ground speeds.

The mulching kit is an option available for our mowers. This kit, containing 3 multilevel cutting edge blades and add-on containment baffling which bolts to the underside of the mower deck, mulches and pulverizes grass and leaves.

Another benefit of the mulching kit is safety. In fact, the kit greatly reduces the possibility of thrown objects. This is particularly important when mowing around schools, public parks and golf courses.

If you are using a **mulching kit**, you need to reduce your ground speed to under 2 mph (see fig. 11).

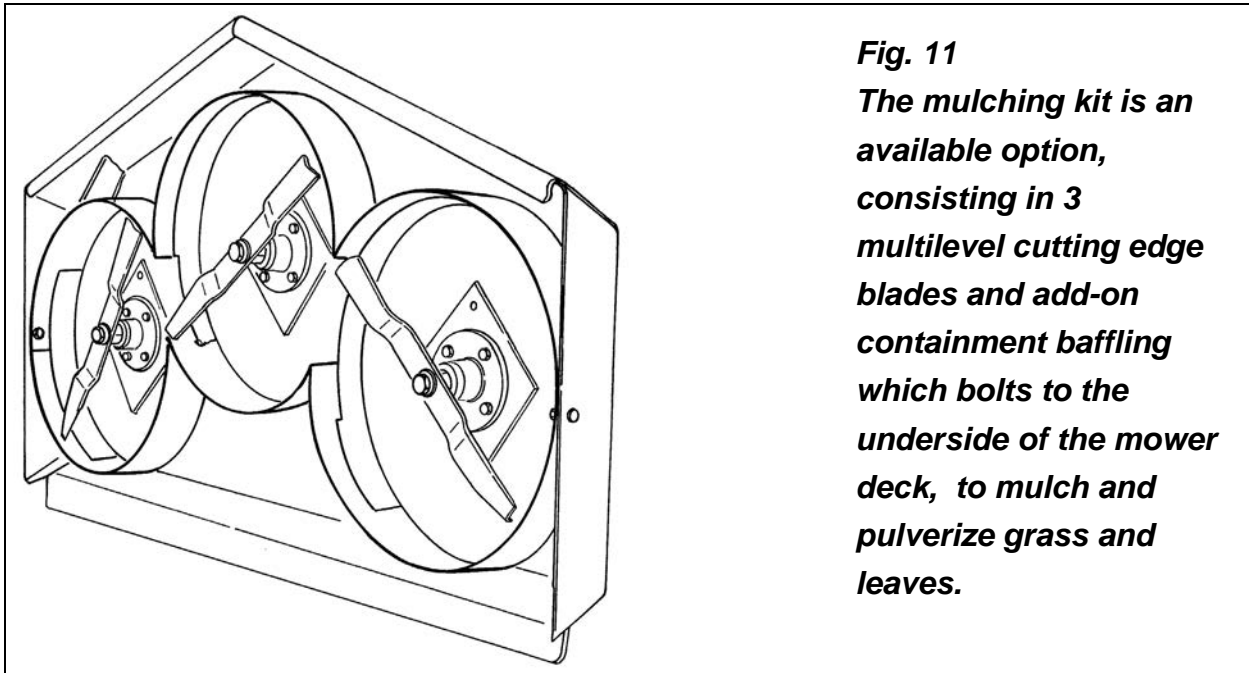

Fig. 11
The mulching kit is an available option, consisting in 3 multilevel cutting edge blades and add-on containment baffling which bolts to the underside of the mower deck, to mulch and pulverize grass and leaves.

3.10 - Operating Techniques

All of the following factors are important in selecting the proper forward speed:

1. Height of grass.
2. Type of grass.
3. Density of grass.
4. Type of terrain.
5. Grass condition, wet or dry.

This mower has been designed to cut grass with heights from 4" to 8". It is recommended to avoid cutting grass taller than 10". For the best results, try cutting the grass at least once per week during growing season. Tall, dense grass should be cut at low speed, while thin medium grass can be cut at a faster ground speed. For cleaner cuts and efficient mowing, the blades must be kept sharp⁷.

Under certain conditions, towing vehicle tires may roll some grass down and prevent it from being cut at the same height as the surrounding area. If this occurs reduce the towing vehicle ground speed. The lower ground speed will permit the grass to at least partially rebound. Under some conditions grass will not rebound enough to be cut evenly, resulting in an uneven appearance. In general, lower cutting height gives a more even cut with less tendency to leave tire tracks. If cut is still not satisfactory, cut the area twice.

⁷ See Sharpening Blades in section 4.03 - Blade Maintenance.

Mow extremely tall grass twice. On the first pass use a high cutting height. On the second pass position the mower at the desired height and, when practical, mow at a right angle in travel to the first pass.

It is better to cut grass more often, than too short. Short grass deteriorates rapidly in hot weather and invites weed growth during growing season.

Plan your pattern to travel straight forward whenever possible. The rear tires of the mower are locked in the running position to help stabilize the mower on inclines.



DANGER: The mower blades can throw objects hundreds of feet which could result in personal or property damage.

Pick up all rocks and other debris before mowing.

Enter new areas carefully. Cut grass higher at first, allowing mower to clear hidden objects.



CAUTION: For emergency reasons learn how to stop the towing vehicle and mower quickly. Stop mower engine, stop towing vehicle engine, lock parking brake and allow the mower blades to come to a complete stop before dismounting the tractor.

3.11 - Uneven Terrain



DANGER: Be careful of rollover when operating towing vehicle and mower over uneven ground.

The following precautions should always be observed when working on uneven terrain:

1. In extremely uneven terrain rear wheel weights, front tractor weights, and/or tire ballast should be used to improve stability.
2. Observe the type of terrain and develop a safe working pattern.
3. Whenever traction or stability is doubtful, first test drive over the terrain without attaching the mower.
4. Operate the implement up and down steep slopes, not across slopes, to prevent the tractor from tipping. Avoid sudden stops and starts, and slow down before changing directions on a slope.
5. Pass diagonally through sharp dips and avoid sharp drops to prevent hanging up the tractor and implement.
6. Slow down on sharp turns and slopes to prevent tipping or loss of control.
7. Avoid tipping the mower while cutting.
8. Watch for holes, roots or other hidden objects. Do not use near the edge of a gully, ditch or stream bank.

3.12 - Transport

Before transporting:

1. Always select a safe ground speed that is appropriate for the terrain.
2. Beware of traffic on public roads. Install a SMV (Slow Moving Vehicle) sign when traveling on roads or streets. Comply with all federal, state and local laws.
3. Reduce ground speed when turning and take care that the implement does not strike obstacles such as trees, fences or buildings.

Fig. 12 - Lifting unit from ground.

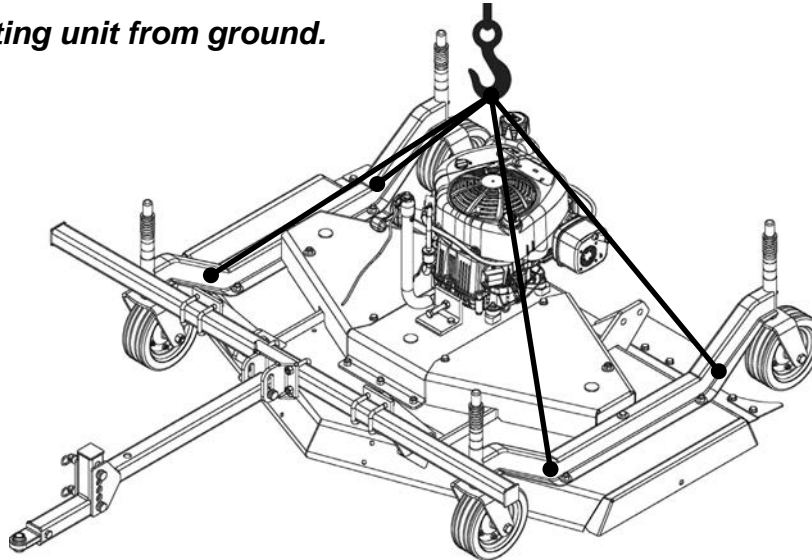

If it is necessary to load the mower on a truck, tie one strap around each wheel arm. Ensure that the load bearing capacity of the straps is sufficient to hold the weight specified in the technical features table for the machine⁸. Adjust the length of the straps to make sure they are the same length and secure them on the other end to the hook on the hoist (**see fig. 12**). Make sure that the lift point is directly above the engine to keep the weight balanced. Slowly raise the unit to make sure the weight is balanced correctly.

⁸ See Table 2 - page 30.

4 - MAINTENANCE



DANGER: Stop mower engine, stop towing vehicle engine, lock parking brake, remove key and disconnect spark plug wire, before performing any service or maintenance.

Install blocks or stands under the mower deck to prevent it from falling. Always use personal protection devices, such as glasses or gloves when performing maintenance.

Keep fingers out of slots to prevent injury.

4.01 - Maintenance Safety

NOTE: For engine maintenance refer to engine manufacturer's operator's manual.



1. Good maintenance is your responsibility.
2. Keep service area clean and dry. Be sure electrical outlets and tools are properly grounded. Use adequate light for the job at hand.
3. Make sure there is plenty of ventilation. Never operate the engine of the mower or the towing vehicle in a closed building. The exhaust fumes may cause asphyxiation.
4. Make no repair or adjustments with the engine running. Before working on the machine, shut off both engines, set the brakes, remove the ignition key and disconnect spark plug wire.
5. Be certain all moving parts on attachment have come to a complete stop before attempting to perform maintenance.
6. Never work under equipment unless it is blocked securely.
7. Always use personal protection devices such as eye, hand and hearing protectors, when performing any service or maintenance.
8. Frequently check mower blades. They should be sharp, free of nicks and cracks and securely fastened.
9. Periodically tighten all bolts, nuts and screws and check that all cotter pins are properly installed to ensure unit is in a safe condition.
10. When completing a maintenance or service function, make sure all safety shields and devices are installed before placing unit in service.
11. Do not attempt to mount a tire unless you have the proper equipment and experience to do the job.
12. Inflating or servicing tires can be dangerous. Whenever possible, trained personnel should be called to service and/or mount tires.

13. If fuel needs to be added, allow engine to cool before filling. Use only approved funnel and container to handle gasoline. Do not fuel tank indoors. Wipe up spilled gasoline.
14. After servicing, be sure all tools, parts and service equipment are removed.
15. Never replace hex bolts with less than grade five bolts unless otherwise specified, i.e. shear bolts⁹.
16. Where replacement parts are necessary for periodic maintenance and servicing, genuine replacement parts must be used to restore your equipment to original specifications. The company will not claim responsibility for use of unapproved parts and/or accessories and other damages as a result of their use.
17. Unauthorized modifications to the machine may impair the function and/or safety of the machine and reduce its life. If equipment has been altered in any way from original design, the manufacturer does not accept any liability for injury or warranty.

4.02 - Service

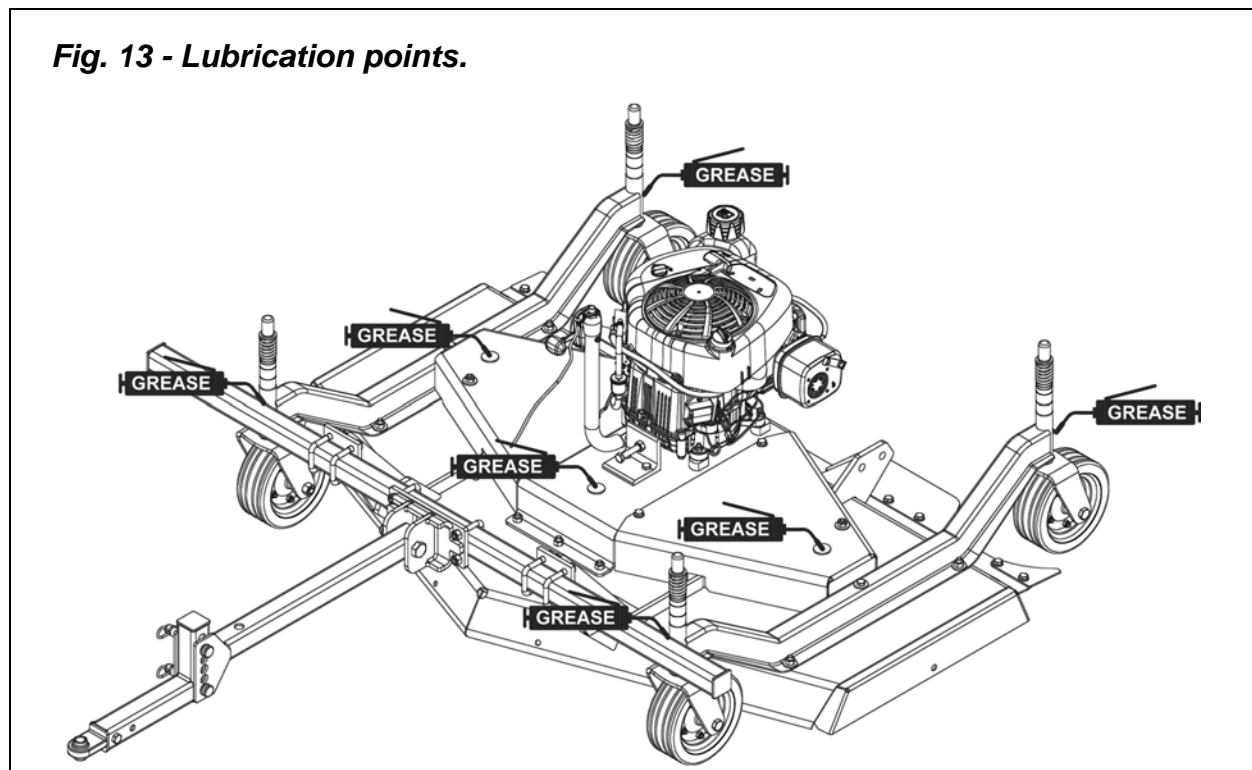

The accompanying illustration shows lubrication points. The chart gives the frequency of lubrication in hours, based on normal operating conditions. Severe or unusual conditions may require more frequent lubrication.

Use a good quality SAE multipurpose type grease for all locations shown. Be sure to clean fittings thoroughly before using grease gun.

Refer to engine manufacturer's operator's manual for service requirements on engine.

⁹ Refer to Table 1 - Torque Specifications, page 30.

Hourly:

1. Check the condition of mower blades for nicks or dull edges. Sharpen if necessary.
2. Replace bent or damaged blades¹⁰.
3. Also check blades for damage after hitting an obstruction.
4. Clean foreign material from mower deck and belt area.

Every 8 hours:

1. **Lubricate the wheel yokes:** Apply two or three shots of grease to the wheel arm grease fittings (**see fig. 13**).
2. **Engine oil level:** Add oil as necessary. See the engine manufacturer's operator's manual for further information on engine.

Every 25 hours: Check hardware tightness; mower vibrations can loosen bolts. Check tightness of the hardware periodically, using Table 1 as a guide¹¹.

Every 50 hours:

1. Lubricate the three spindles with multipurpose grease (**see fig. 13**). Pump grease until you see it seep through the hole on the bottom cover (**see #5, fig. 14**) of the spindle. The top grease fittings are easily accessible from the top of the deck by simply removing the plastic dust guards.
2. Check belt tension¹².

4.03 - Blade Maintenance



WARNING: To avoid possible injury always wear proper eye and hand protection when servicing mower blade.

In order for the mower to work properly and to always obtain a precision cut, proper blade maintenance is important.

Blades must be kept sharp, at their original length and corners maintained. A blade must be replaced if, due to wear or damage, its original shape has been distorted.

Installing or removing blades

If the mower blades need to be installed, do the following:

1. The blade turns in a **counter clockwise** direction when viewed from the bottom of the deck. The cutting edge must be towards the direction of rotation. The lift wing of the blades is closest to the deck and the cutting edge away from it (**see fig. 14**).
2. Install the cup washer (**see fig. 14**) over the blade bolt and secure the blade in place as described above.
3. With a wrench, block the spindle and tighten the bolt to 103 lb.ft. (**see fig. 15**).
4. To remove the blades reverse the procedure.

¹⁰ See Section 4.03 - Blade Maintenance.

¹¹ See Table 1, Torque Specifications, page 30.

¹² See Section 4.04 - Belt Tension.

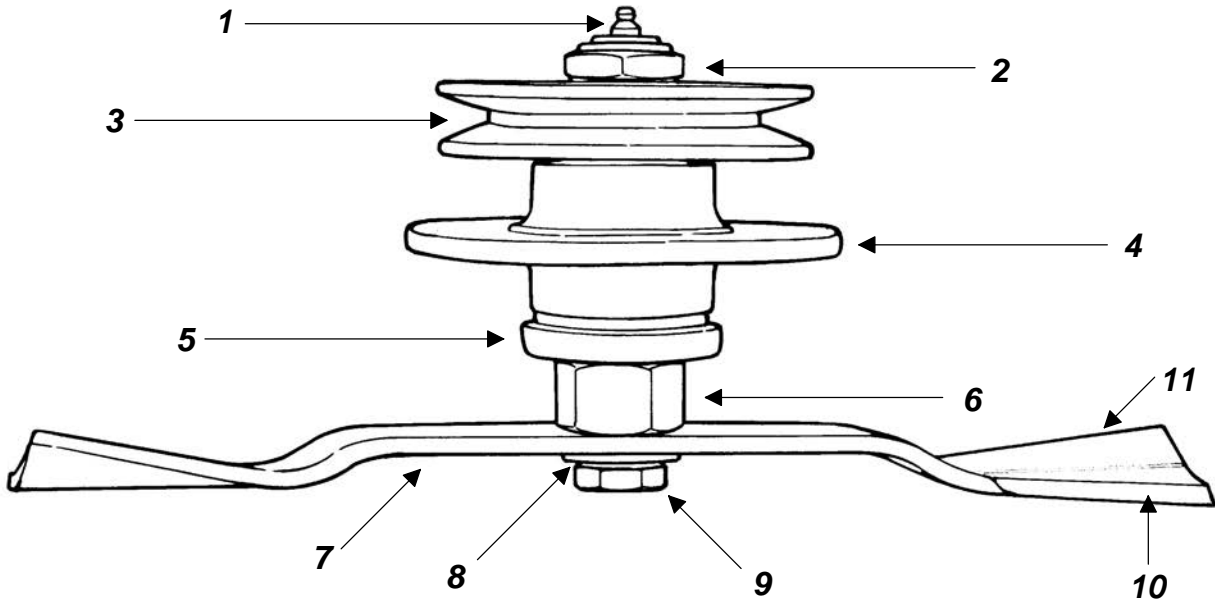

Fig. 14 - Spindle assembly.

- | | | |
|-------------------|----------------------------------|--------|
| 1. grease fitting | 7. blade | Ground |
| 2. hexagonal nut | 8. cup washer | |
| 3. pulley | 9. blade bolt | |
| 4. rotor support | 10. cutting edge close to ground | |
| 5. cover | 11. lift wing | |
| 6. shaft | | |

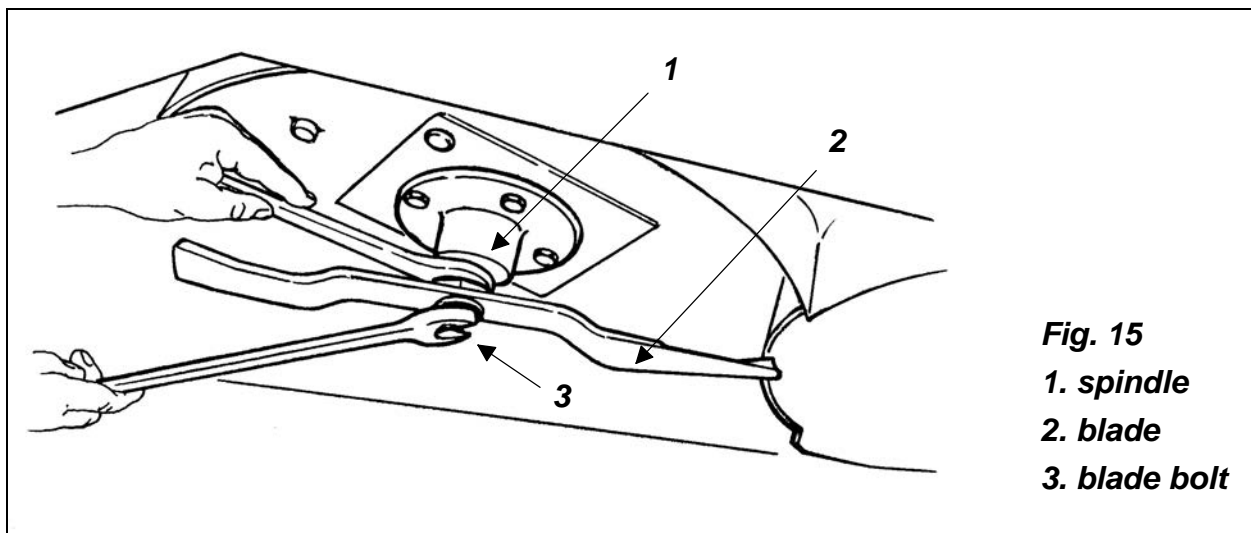

Fig. 15
 1. spindle
 2. blade
 3. blade bolt



WARNING: Do not substitute blades or any bolt for the blade retaining bolt. Company blades and blade retaining bolts are specially made for this application. Using non original parts can effect the quality of cut and may also cause damage to the mower.



DANGER: Proper torque must be used when tightening the blade retaining bolt. If these safety precautions are not followed, the blade could come off during operation and be thrown hundreds of feet from the mower.

Sharpening Blades

Blade sharpening is extremely important in order to get the best cutting results. Sharp blades permit a high quality cut.

To sharpen blades, first remove them following the above instructions.

Place the blade in a vise and sharpen them by using a hand file or grinder. **Do not sharpen the blades to a sharp cutting edge.** The cutting edge should be between $\frac{1}{64}$ " to $\frac{1}{32}$ " to prevent excessive pitting and dulling of the blades. Sharpen both ends of the blade equally for balance and always maintain corners. Always keep all three blades sharpened equally in order to maintain balance.



CAUTION: Unbalanced or warped blades can cause damage to the mower and/or personal injury. Replace damaged blades before operating the mower. Sharpen both ends of the mower blades equally or until the blade is balanced.

4.04 - Belt Tension

The C30-CE5H mower is equipped with two belts, a main drive belt that runs from the centrifugal clutch to the center spindle pulley and a secondary belt that runs between the 3 pulleys.

Belt tension control

1. Check the main drive belt by applying a force of 3-4 lb. pushing against the belt halfway between the centrifugal clutch and the center spindle pulley. The belt deflection should be between $\frac{1}{8}$ "- $\frac{1}{4}$ ".
2. Check the secondary belt tension by applying a force of 12-15 lb. pushing against the belt halfway between the pulleys. The belt deflection should be between $\frac{5}{16}$ "- $\frac{3}{8}$ ".

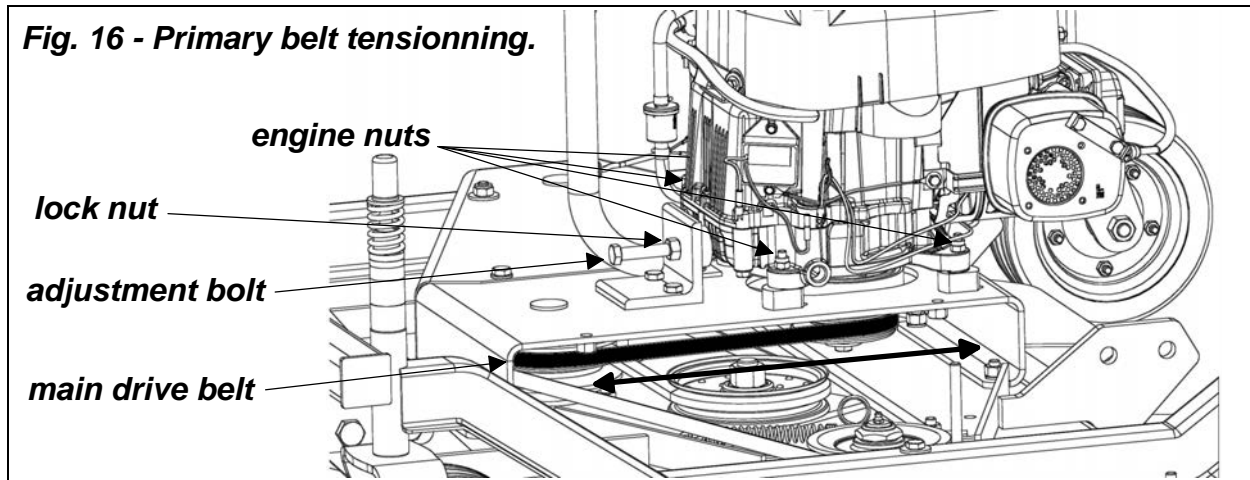

Belt tension adjustment

1. If the main drive belt deflects more than $\frac{1}{4}$ " , tighten the belt by loosening the four engine nuts along with the lock nut on the adjustment bolt and turning the adjustment bolt clockwise until the belt is within the specified range. Then re-tighten the four engine nuts and the lock nut on the adjustment bolt.
2. The secondary belt has an automatic belt tensioner. The tension is created by a spring connecting a tensioner pulley to a fixed hitch plate with 2 positions (**see fig. 17**). Upon delivery, the spring is located in the first position. When the belt stretches after use, adjust the tension by relocating the spring in the other hole. If the belt has stretched to the point that the belt is not tight enough even in the second hole, then it is necessary to replace the belt.

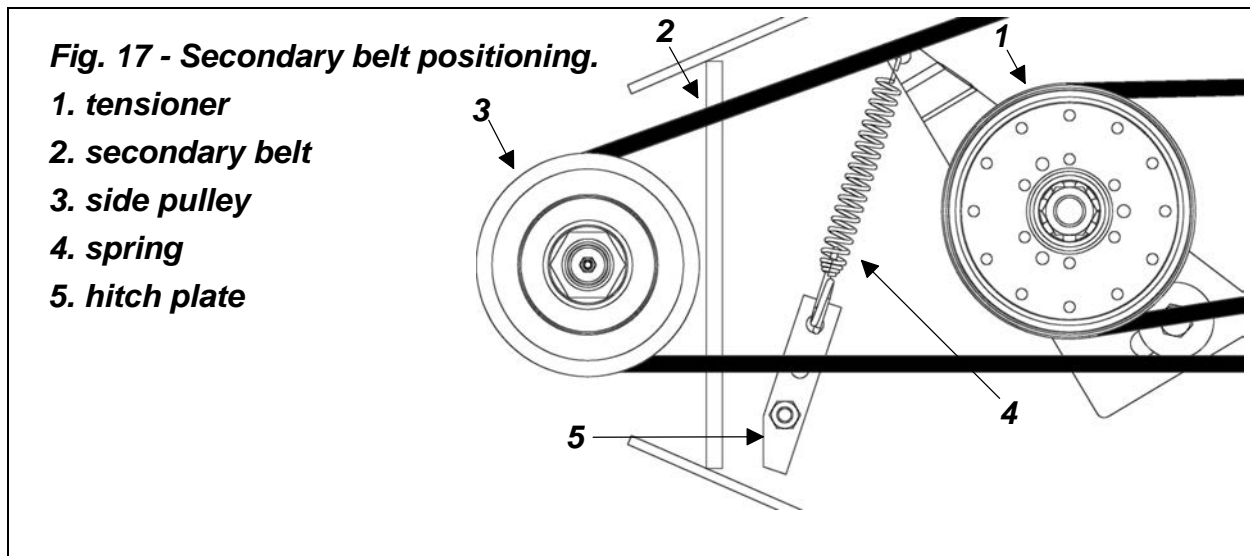

4.05 - Belts Replacement

If the belts have stretched or damaged to the point where the proper tension cannot be obtained they must be changed.

To replace the belts (**see #4 & 8, fig. 18**) do the following:

1. Remove belt shield. Clean foreign material from the mower deck and belt area.
2. Loosen the four engine nuts.
3. Loosen the belt tensioner bolt.
4. Loosen rear nuts holding central plate (do not remove them).
5. Remove front nuts holding central plate.
6. Release spring tensioner to loosen secondary belt.
7. Lift the front of the central plate and remove old belts.
8. Replace both belts.
9. Lower central plate. Replace front nuts. Tighten front and rear nuts holding down central plate. Tighten four engine bolts. Tighten belt tensioner bolt.
10. Replace spring tensioner.
11. Check both belts for proper tension.
12. Reinstall the belt shields.

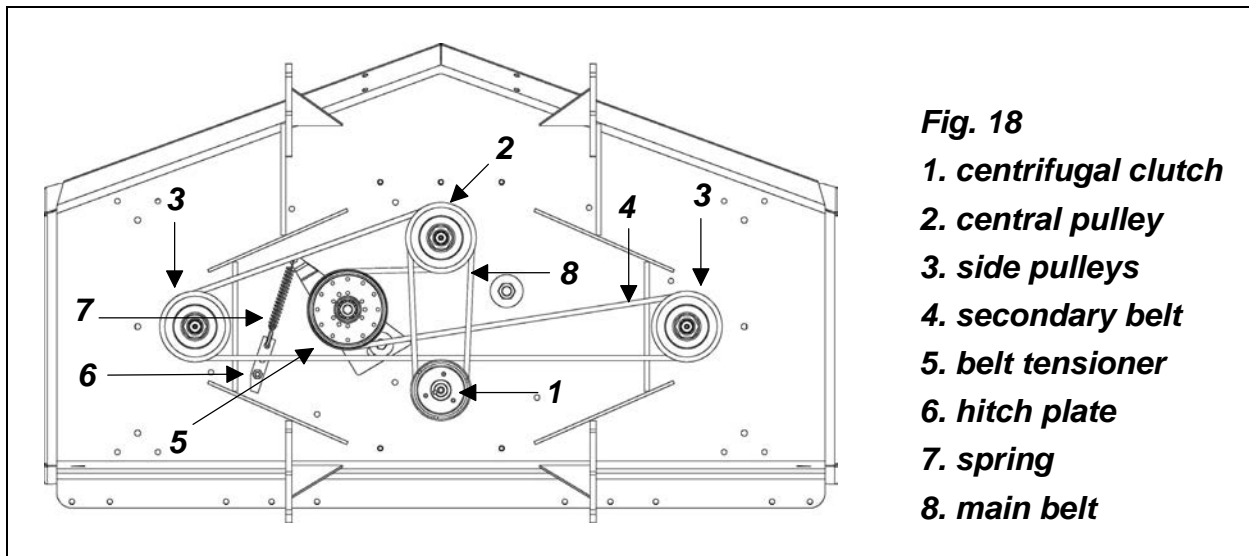







Fig. 18

1. centrifugal clutch
2. central pulley
3. side pulleys
4. secondary belt
5. belt tensioner
6. hitch plate
7. spring
8. main belt

TABLE 1 - TORQUE SPECIFICATIONS

Metric (ISO) treaded bolts head marking		 Class 5.8	 Class 8.8	 Class 10.9	Inch (SAE) treaded bolts head marking		 Grade 2	 Grade 5	 Grade 8					
Bolt size mm	Thread mm	N.m	ft-lb	N.m	ft-lb	N.m	ft-lb	N.m	ft-lb	N.m	ft-lb	N.m	ft-lb	
M5	0.8	4	3	6	4	9	7	1/4" 20	7	5	11	8	16	12
M6	1	6	4	10	7	15	11	1/4" 28	8	6	13	10	19	14
M8	1.25	16	12	25	18	36	27	5/16" 18	15	11	24	17	33	25
M8	1	17	13	26	19	38	28	5/16" 24	17	13	26	19	37	27
M10	1.5	31	23	48	35	71	52	3/8" 16	27	20	42	31	59	44
M10	1.25	33	24	51	38	75	55	3/8" 24	31	23	47	35	67	49
M10	1	35	26	53	39	78	58	7/16" 14	43	32	67	49	95	70
M12	1.75	54	40	84	62	123	91	7/16" 20	48	36	75	55	106	78
M12	1.5	56	41	87	64	128	94	1/2" 13	66	48	102	75	144	106
M12	1.25	59	44	90	66	133	98	1/2" 20	75	55	115	85	163	120
M14	2	84	62	133	98	195	144	9/16" 12	95	70	147	109	208	154
M14	1.5	94	69	142	105	209	154	9/16" 18	106	79	164	121	232	171
M16	2	131	97	206	152	302	223	5/8" 11	132	97	203	150	287	212
M16	1.5	141	104	218	161	320	236	5/8" 18	149	110	230	170	325	240
M18	2.5	181	133	295	218	421	310	3/4" 10	233	172	361	266	509	376
M18	2	196	145	311	229	443	327	3/4" 16	261	192	403	297	569	420
M18	1.5	203	150	327	241	465	343	7/8" 9	226	167	582	430	822	606
M20	2.5	256	189	415	306	592	437	7/8" 14	249	184	642	473	906	668
M20	1.5	288	212	454	335	646	476	1" 8	339	250	873	644	1232	909
M22	2.5	344	254	567	418	807	595	1" 12	371	273	955	704	1348	995
M22	1.5	381	281	613	452	873	644	1-1/8" 7	480	354	1077	794	1746	1288
M24	3	444	327	714	526	1017	750	1-1/8" 12	539	397	1208	891	1958	1445
M24	2	488	360	769	567	1095	808	1-1/4" 7	677	500	1519	1120	2463	1817
M27	3	656	484	1050	774	1496	1103	1-1/4" 12	750	553	1682	1241	2728	2012
M27	2	719	530	1119	825	1594	1176	1-3/8" 6	888	655	1992	1469	3230	2382
M30	3.5	906	668	1420	1047	2033	1499	1-3/8" 12	1011	746	2268	1673	3677	2712
M30	2	1000	738	1600	1180	2250	1659	1-1/2" 6	1179	869	2643	1949	4286	3161
M36	4	1534	1131	2482	1830	3535	2607	1-1/2" 12	1326	978	2974	2194	4823	3557

When using lock washers with nuts, increase torque values by 5%.

TABLE 2 - C30 ENGINE MOWER - TECHNICAL FEATURES

Series C30, rear discharge, cat. 1 ball										
Model	Working width	Overall width	Weight lb.	Rotor rpm/min	Blades tip speed ft/min	# Blades	Cutting height	# Belts & type	# Wheels & size	Engine
C30-CE5H	60"	65"	460	2673	14173	3	1" - 4"	2 BX	4 - 8.4"x3.2"	Briggs & Stratton 11.5 HP

TABLE 3 - OVERALL DIMENSIONS

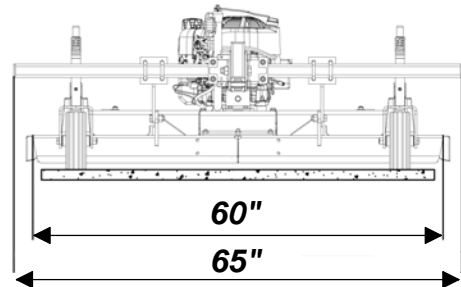
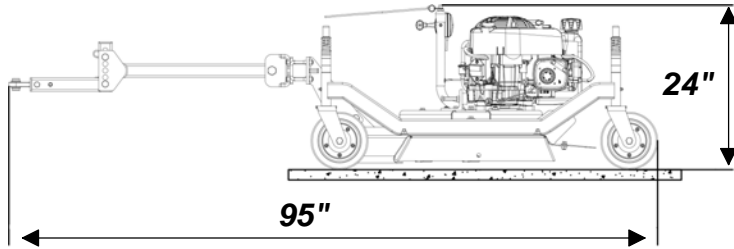

5 - REPAIR PROCEDURES



CAUTION: All repair procedures must be done by authorized dealerships. It is not recommended that untrained individuals perform any repair work. The following operations are detailed for qualified personnel only.

5.01 - Blade Spindle

To remove a blade spindle:

1. Remove the belt¹³.
2. Remove the nut holding the pulley to the spindle shaft (see fig. 14).
3. Remove the blades¹⁴.
4. Unbolt the bolts holding the rotor support to the mower deck.
5. If necessary remove and replace the bearings from the rotor using presses or extractors.
6. Reassemble in reverse order ensuring that the nut securing the top pulley (see fig. 14) is tightened to 118 lb. ft.

5.02 - Suggested Spare Parts

It is suggested that the following spare parts be kept on hand for the mower at all times to prevent a minor problem from delaying work.

Description	Quantity
Blades	3
Blade bolts	3
Washers	3
Belts	2

5.03 - Storage

After seasonal use it is important to perform the following for prolonged storage:

1. Wash the mower carefully.
2. Inspect the mower and replace worn or damaged parts.
3. Tighten all hardware.
4. Grease all areas indicated under Maintenance¹⁵.
5. Loosen the belts if the mower is to be stored for an extended length of time.
6. Cover the mower from the elements in order to have it in perfect condition for the start of the next season.

¹³ See Section 4.05 - Belt Replacement.

¹⁴ See Section 4.03 - Blade Maintenance.

¹⁵ See Chapter 4 - Maintenance.

6 - TROUBLESHOOTING



WARNING: Be sure mower engine and towing vehicle engine are off, parking brake is locked, key is removed and spark plug wire is disconnected before making any adjustments.

PROBLEM	POSSIBLE CAUSE	SOLUTION
Uneven cutting.	Cup washer not between blade and bolt. Ground speed too fast. Blades need sharpening. Caster wheels uneven. Engine not at full rpm.	Check washer location on all 3 spindles. Shift to lower gear. Sharpen blades. Adjust wheel position. Increase engine rpm.
Blades turning but not cutting.	Direction of blades is wrong.	Blade should turn CCW when you face deck bottom. See Blades Maintenance section.
Belt slippage.	Lack of tension. Object clogging mower. Debris in pulleys.	Tighten belt. Remove object. Clean pulleys.
Mower vibrates.	Object wrapped around blade. Belt damaged.	Remove object. Replace belt.
Belt squeal.	Belt slipping.	Tighten belt.
Grass build up at exit.	Wet grass. Grass too high.	Allow grass to dry. Raise mower, shift to lower gear, make two passes over grass. Mow grass high 1st pass, 2nd pass cut to desired height.
Belts are tight when installing.	Wrong belt size. Installed belts incorrectly.	Check belt size. See Belts Replacement section.
Streaking conditions in swath.	Too wet to mow. Blades cannot cut grass pressed down by wheels. Dull blades. Blades worn down, preventing overlap.	Allow grass to dry. Maintain engine speed and shift to lower gear. Sharpen blade. See Blades Maintenance section. Change blades.
Cut grass windrows.	Ground speed too low.	Increase ground speed. Check engine speed.
Mower does not tow straight behind tractor.	Front wheel yokes loose.	Tighten nuts on front yokes to prevent wheels from pivoting.

PROBLEM	POSSIBLE CAUSE	SOLUTION
Mower engine stalls often.	Mower engine speed too slow. Ground speed too fast. Engine malfunction.	Increase engine speed. Decrease speed. Refer to Engine Operator's Manual.
Mower engine does not start.	Engine out of gasoline. Safety kill switch disengaged. Throttle lever not on "CHOKE". Carburetor flooded. Engine not grounded.	Refill engine. Re-insert safety kill switch. Place lever on "CHOKE" Clean out carburetor. Check wiring for correct grounding.

7 - PRE-DELIVERY CHECKLIST

To the dealer: Inspect the machine thoroughly after assembly to assure it is functioning properly before delivering it to the customer. The following checklist is a reminder of points to cover. Check off each item as it is found satisfactory or after proper adjustment is made.

- Engine oil level.
- Gearbox oil level.
- Guards and shield properly fastened.
- Lubrication of grease fittings.
- All hardware properly tightened.
- All decals properly located and readable (**see fig. 2**).
- Blades properly installed, blade bolts and nuts tightened.
- Overall condition (touch up scratches, clean and polish).
- Test run, check for excessive vibration or overheating of bearings.
- Operator's Manual.

Review the Operator's Manual with the customer. Explain the following:

- Warranty.
- Safe operation and service.
- Correct machine installation and operation.
- Daily and periodic lubrication, maintenance and inspections.
- Troubleshooting.
- Operational procedures and storage.
- Parts and service.
- Fill out the Pre-Delivery Checklist and Warranty Registration form.
- Give customer the Operator's Manual and encourage the customer to read the manual carefully.

IMPORTANT: Warranty is not valid unless Pre-Delivery Checklist and Warranty Registration form in Operator's Manual is completed in detail and mailed to the Company.

Model Number: _____

Serial Number: _____

Delivery Date: _____

Dealer's Signature: _____

8 - WARRANTY

BEFCO's responsibility will be limited to substitution of the acknowledged defective merchandise to the same place of delivery as the previous one was supplied.

1. LIMITED WARRANTY

BEFCO, Inc. herein referred to as the Company, warrants its machines and related accessories, hereafter referred to as the Machine, to be free from defects in material and workmanship, for a period of twelve (12) months from the date of invoice to the first registered owner; this limited warranty does not apply to common wear items and excludes engine, belts, shear pins, oil, grease, tires, tubes, hydraulic hoses, knives and PTO shafts.

Labor will be reimbursed at \$40.00 per hour based on BEFCO's time schedule.

Cost of transport to the servicing dealer is the responsibility of the customer.

Warranty coverage shall not be transferable from the first owner to any subsequent owner.

2. DISCLAIMER OF ALL OTHER WARRANTIES AND REMEDIES

Neither the Company nor any company affiliated with the Company makes any warranties, representations or promises, expressed or implied, as to the quality, performance or application of its products other than those set forth herein and does not make any implied warranty of merchantability or fitness.

The only remedies the purchaser has in connection with the breach, or performance of any warranty on the Company's Machine are those set forth herein. In no event will the dealer, the Company, or any company affiliated with the Company, be liable for:

- a. Injuries or damages of any kind or nature, direct, consequential or contingent to person or property.
- b. Any expenses incurred by the owner to repair, replace or rework any allegedly defective item.
- c. Any loss, cost, forfeiture or damages (including loss of profits; loss of crops; loss because of delay in field operations; any expenses or loss incurred for labor, supplies, substitute machine rental; liabilities of the owner to its customers or third persons; and all other consequential damages, losses, liabilities or damages for any other reasons) whether direct or indirect, and whether or not resulting from or contributed to by the default or negligence of the Company, its agents, employees and subcontractors which might be claimed as a result of the use or failure of the equipment delivered.

The Company's liability based on this limited warranty or any other applicable laws shall be limited to replacement or refund of the purchase price of the product.

The limited warranty extended herein gives you specific rights and you may also have other rights which vary from state to state. Neither the dealer nor the Company personnel has the authority to make any representation or to modify the terms and limitations of this warranty in any way.

Other than the limited warranty extended hereby there is no other expressed warranty in connection with the design, safety or use of any of the Company's products except as to title. All implied warranties are expressly disclaimed pursuant to the terms of this warranty.

3. CUSTOM WORK

If the Machine is used for commercial purposes such as custom work, the period warranted for the Machine is limited to six (6) months from the date of delivery to the first registered owner and does not cover any labor charges incurred.

4. RENTAL

If the Machine is used for rental purposes the period warranted for the Machine is limited to thirty (30) days from the date of delivery to the first registered owner and does not cover any labor charges incurred.

5. REGISTRATION

In order to qualify for coverage on this limited warranty, the product and name of the original purchaser must be registered with the Company by a completed Machine Pre-Delivery Checklist and Warranty Registration along with a copy of the dealer's invoice to the first registered owner to the Company within fourteen (14) days after the date of delivery to the original purchaser.

6. WARRANTY SERVICE

Warranty Service must be performed by a dealer authorized by BEFCO. If the warranty service requested is approved, the owner shall pay only for labor beyond the rate allowed, for overtime labor, and for any mileage charge for transporting the equipment to and from the dealer's shop. It is assumed that the dealer has the appropriate general and special tools to service the Machine. Time required for replacement of knives, oil, grease and to remove excessive dirt from the Machine is not subject to reimbursement by the Company. The owner is required to clean the Machine before presenting it to the dealer for service work. The Machine must be delivered within thirty (30) days after failure date by the owner to the dealer to be eligible for warranty consideration.

7. UNAPPROVED SERVICE OR MODIFICATION

All obligations of the Company under this limited warranty shall be terminated if:

- a. Proper service and operation instructions as outlined in the Operator's Manual and on the instruction sticker on the Machine, are not followed.
- b. The Machine is modified or altered in any way not approved by the Company.
- c. The Company does not receive a copy of the dealer's invoice to the first registered owner within fourteen (14) days from the date of delivery.
- d. The Company has not been paid in full, by the dealer, for the Machine.

8. ACCIDENTS AND NORMAL MAINTENANCE

This limited warranty covers defective material and workmanship. It does not cover depreciation or damage caused by normal wear, accidents, improper maintenance, improper protection or improper use. The costs of normal maintenance or repairs for accidents or improper use, and related labor will be borne by the owner.

9. REPLACEMENT PARTS

BEFCO, Inc. warrants replacement parts to be free from defect in material and workmanship for a period of thirty (30) days from the date of delivery to the original purchaser.

WARRANTY REGISTRATION

BEFCO, Inc.
P.O. Box 6036
Rocky Mount, NC 27802-6036

Tel: (252) 977.9920 - Fax: (252) 977.9718

Dealer _____ Acct. # _____	Retail Customer _____
Street _____ Country _____	Street _____
Town _____ State _____ Zip _____	Town _____ State _____ Zip _____
Date of delivery _____ Invoice # _____	Phone _____
Model # _____ Serial # _____	
<p>Pre-Delivery Checklist:</p> <p><input type="checkbox"/> Oil in engine.</p> <p><input type="checkbox"/> Greased fittings.</p> <p><input type="checkbox"/> Safety guards in place.</p> <p><input type="checkbox"/> All hardware tight.</p> <p><input type="checkbox"/> Bolts torqued correctly.</p> <p><input type="checkbox"/> Attached unit to tractor. Yes/No.</p> <p><input type="checkbox"/> Field adjusted. Yes/No.</p> <p><input type="checkbox"/> Test run. Dry/Infield.</p> <p><input type="checkbox"/> Safety decals.</p> <p><input type="checkbox"/> Operator's Manual.</p> <p>The machine described above, had been prepared for delivery according to the Pre-Delivery Checklist and the Customer has been instructed in its care and operation and the condition of warranty.</p>	<p>Tractor make: _____</p> <p>Model: _____; HP _____</p> <p>Type of operation: Private homeowner, Landscaping, Commercial maintenance, Golf Course, Municipality, Turf Farm, others: _____</p> <p>Approximate number of acres machine will be used on annually: _____</p> <p>I hereby acknowledge that: I have received and accepted delivery of the machine described. The equipment was checked thoroughly for loose or missing parts and has been adjusted in accordance with the Pre-Delivery Checklist. I have read and understand the nature and extent of the warranty and understand clearly that there were and are no other representations of warranties either expressed or implied, made by anyone. I have been advised on proper operation, maintenance and lubrication procedure of this equipment. I have been instructed on and do understand the application, limitation and capacities this equipment was designed and recommended for, all as described in the Operator's Manual and literature published by the Company.</p>
Inspected by: _____	
Date: _____	Date: _____
Dealer's Signature: _____	Customer's Signature: _____

This registration along with a copy of the invoice must be sent to BEFCO, Inc. within 14 days of date of purchase.

Sender:

Fold here

*Place stamp
here*

BEFCO, Inc.

Warranty Department

P.O. Box 6036

Rocky Mount, NC 27802-6036

Cut along this line

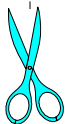

BEFCO®

Parts Manual

CYCLONE

Engine Driven Grooming Mower

C30-CE5H

(serial #345293 & above)

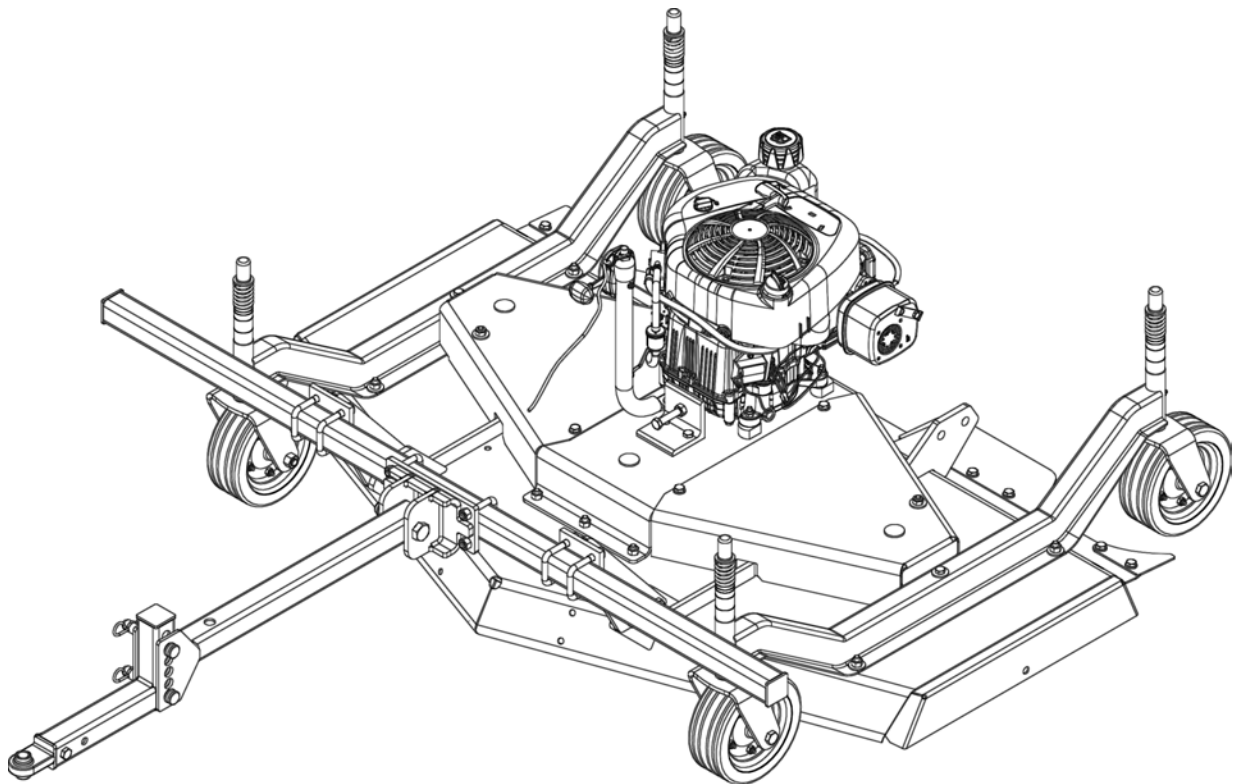

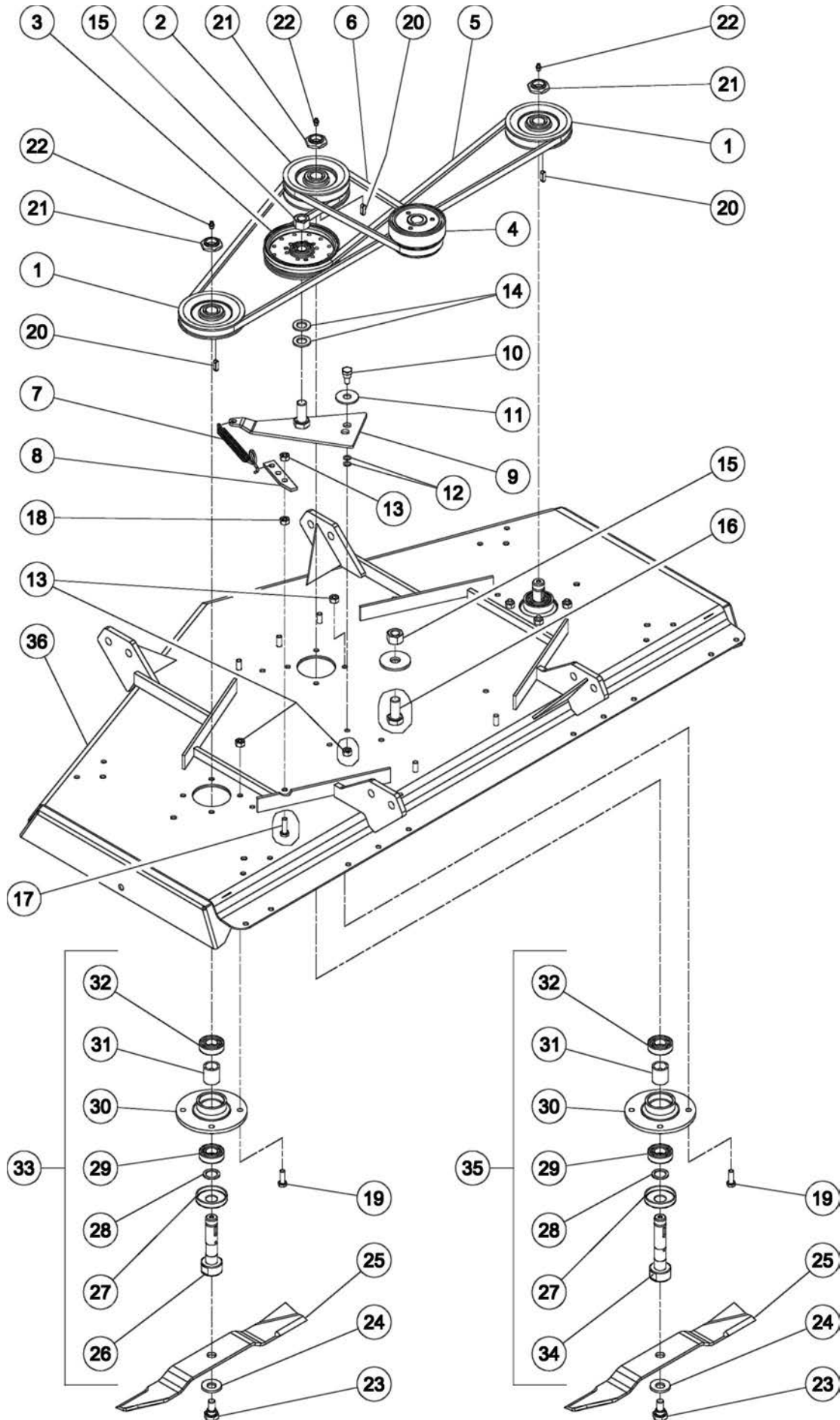

Ref.	Part #	Description	Qty.
1	000-8666	Pulley SPB 130x1, side spindles	2
2	000-6621	Pulley SPB 130x2, center spindle; C30-CE5H	1
3	000-8561	Pulley, belt tensioner	1
4	000-8851	Centrifugal clutch	1
5	000-8942	Belt BX124	1
6	000-8850	Belt BX36	1
7	000-9726	Spring	1
8	000-8571	Hitch plate	1
9	005-1741	Belt tensioner support	1
10	005-1751	Bolt, belt tensioner SP M10-1.50	1
11	001-7354	Washer fender Ø16 Z	1
12	005-1754	Shim Ø10x16x0.2	-
13	003-0156	Nut PT M10-1.50 C6 Z	14
14	004-6555	Washer flat Ø20 Z	2
15	000-5507	Nut PT M20-2.50 C6 Z TK	2
16	000-9538	Bolt HH M20-2.50x45 C8.8 Z F	1
17	009-1281	Bolt HH M10-1.50x35 C8.8 Z F	1
18	000-1279	Nut HH M10-1.50 C6 TK Z	1
19	000-1278	Bolt HH M10-1.50x30 C8.8 Z F	12
20	000-6639	Key 8x7x25	3
21	000-6698	Nut SP M25-1.50 Z	3
22	002-9036	Grease fitting Ø8 press in	3
23	000-6659	Bolt blade SP M14-1.50x32	3
24	000-8560	Washer conical spring Ø18 Z	3
25	000-6641	Blade standard 60"	3
	000-6641M	Blade mulching 60"	3
	000-6641B	Blade high lift 60"	3
	000-6641F	Blade low lift 60"	3
26	000-8557	Spindle shaft	2
27	000-6636	Cover	3
28	000-6606	Shim Ø25x35x2	3
29	000-6626A	Bearing 6205-ZZ	3
30	000-8538	Support, spindle shaft	3
31	000-8536	Spacer	3
32	000-6634A	Bearing 6205-Z	3
33	000-8533	Spindle assembly	2
34	000-8807	Shaft, central spindle; C30-CE5H	1
35	000-8533M	Central spindle assembly, complete; C30-CE5H	1
36	025-1501P	Frame, rear discharge 60"	1

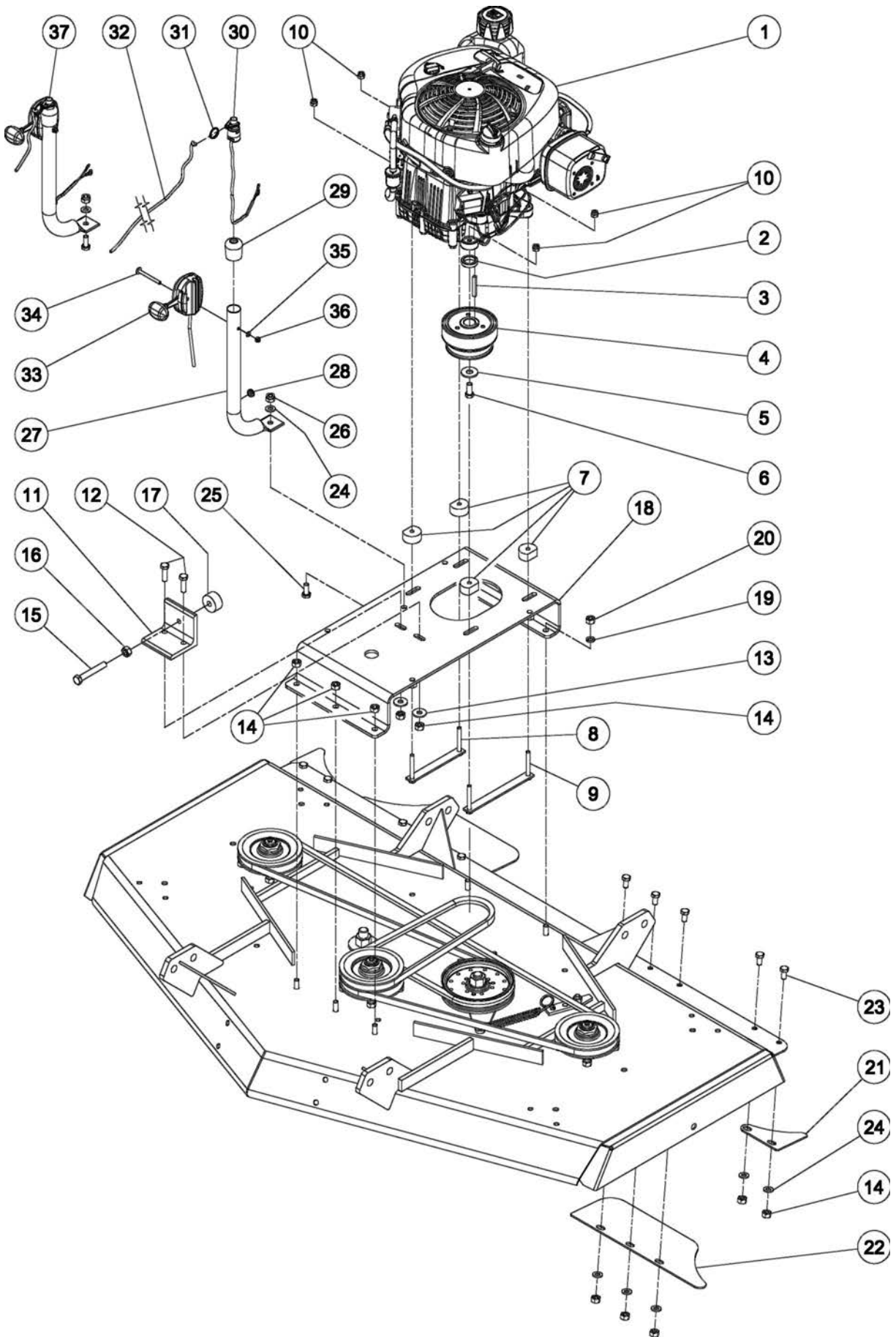

Ref.	Part #	Description	Qty.
1	000-8858	Engine, Briggs & Stratton	1
2	000-8853	Spacer	1
3	503-892B	Key 1/4"x2"	1
4	000-8851	Centrifugal clutch	1
5	007-6106	Washer flat Ø12 Z	1
6	000-8855	Bolt HH 7/16"-20x1.00" G8 Z F	1
7	000-8870	Spacer, engine adjustment	4
8	000-8861	Engine plate, short	1
9	000-8865	Engine plate, long	1
10	009-1384	Nut ES M08-1.25 Z TK	4
11	000-8874	Plate, belt tensioner	1
12	009-1281	Bolt HH M10-1.50x35 C8.8 Z F	2
13	003-0157	Washer flat Ø10 Z	2
14	003-0156	Nut PT M10-1.50 C6 Z TK	15
15	000-7128	Bolt HH M12-1.75x80 C8.8 Z F	1
16	000-1106	Nut HH M12-1.75 C6 Z MD	1
17	503-370B	Spacer, belt tensioner	1
18	020-8430B	Central plate 60"; C30-CE5H	1
19	000-1280	Washer lock Ø10	2
20	000-1279	Nut HH M10-1.50 C6 Z TK	2
21	005-1858	Rear protection, outer 60"	2
22	005-1856	Rear protection, inner	2
23	000-6349	Bolt HH M10-1.50x20 C8.8 Z F	10
24	000-2034	Washer flat Ø10 W	11
25	003-3176	Bolt HH M10-1.50x25 C8.8 Z F	1
26	001-5237	Nut ES M10-1.50 Z TN	1
27	000-8810	Stand, throttle	1
28	000-8811	Grommet Ø16	1
29	000-8812	Cap Ø30, throttle stand	1
30	000-8815	Kill switch, complete	1
31	000-8824	Ring Ø25	1
32	002-3705	Nylon rope, front 2930 mm.	1
33	501-682B	Throttle	1
34	000-8730	Bolt CR M06-1.00x80 C4.8 Z	1
35	005-0166	Washer flat Ø06 Z	1
36	005-0165	Nut ES M06-1.00 Z TK	1
37	000-8825	Throttle & kill switch assembly, complete	1

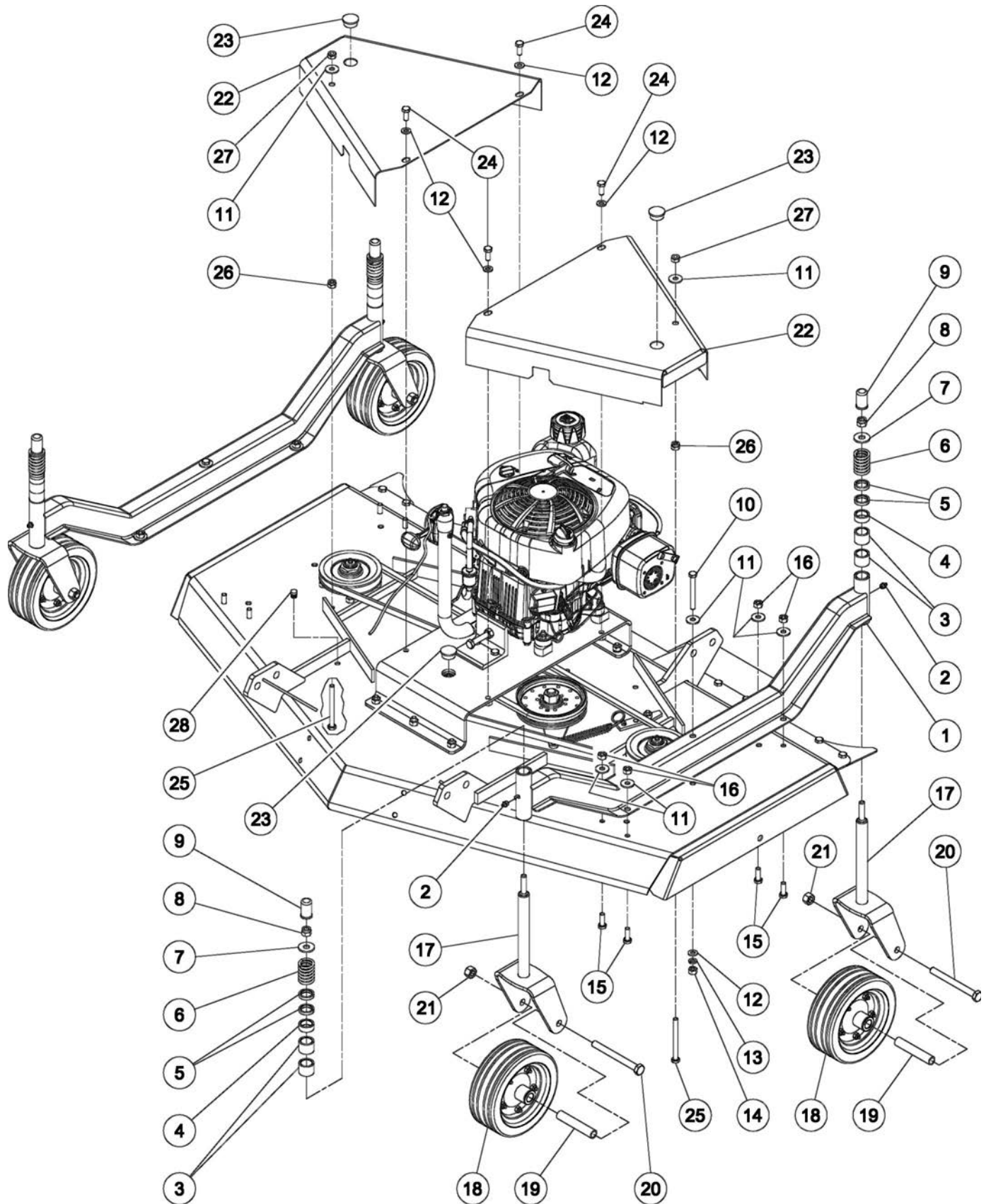

Ref.	Part #	Description	Qty.
1	020-8761	Wheel arm 60"	2
2	000-1065	Grease fitting M10-1.00	4
3	000-6586	Spacer, height adjustment 1"	8
4	000-6587	Spacer, height adjustment ½"	4
5	000-6589	Spacer, height adjustment ¼"	8
6	000-8778	Spring Ø31x50	4
7	007-6106	Washer fender Ø12 Z	4
8	001-3345	Nut ES M12-1.75 Z TK	4
9	000-8779	Cap, threaded yoke	4
10	002-6185	Bolt HH M10-1.50x90 C8.8 Z P	2
11	003-0157	Washer fender Ø10 Z	12
12	000-2034	Washer flat Ø10 W	6
13	000-1280	Washer lock Ø10 Z	2
14	000-1279	Nut HH M10-1.50 C6 TK Z	2
15	000-1278	Bolt HH M10-1.50x30 C8.8 Z F	8
16	003-0156	Nut PT M10-1.50 C6 TK Z	8
17	000-8776	Wheel yoke; C30-CE5H	4
18	000-8526	Wheel w/hard tire, complete	4
	000-6613	Bushing nylon, hard tire (not shown)	8
	000-8797	Air tire (option)	4
	000-6969A	Steel retainer, air tire (not shown)	8
	000-6968	Bearing, air tire (not shown)	8
19	000-8528	Spacer, wheel	4
20	000-6615	Bolt HH M14-2.00x140 C8.8 Z P	4
21	003-0358	Nut PT M14-2.00 C6 Z TK	4
22	020-8817	Belt shield 60"	2
23	000-6647	Cap	3
24	003-3176	Bolt HH M10-1.50x25 C8.8 Z F	4
25	000-8818	Bolt HH M10-1.50x110 C8.8 Z F	2
26	001-4106	Nut ES M10-1.50 Z TK	2
27	001-5237	Nut ES M10-1.50 Z TN	2
28	005-1570	Cap	6

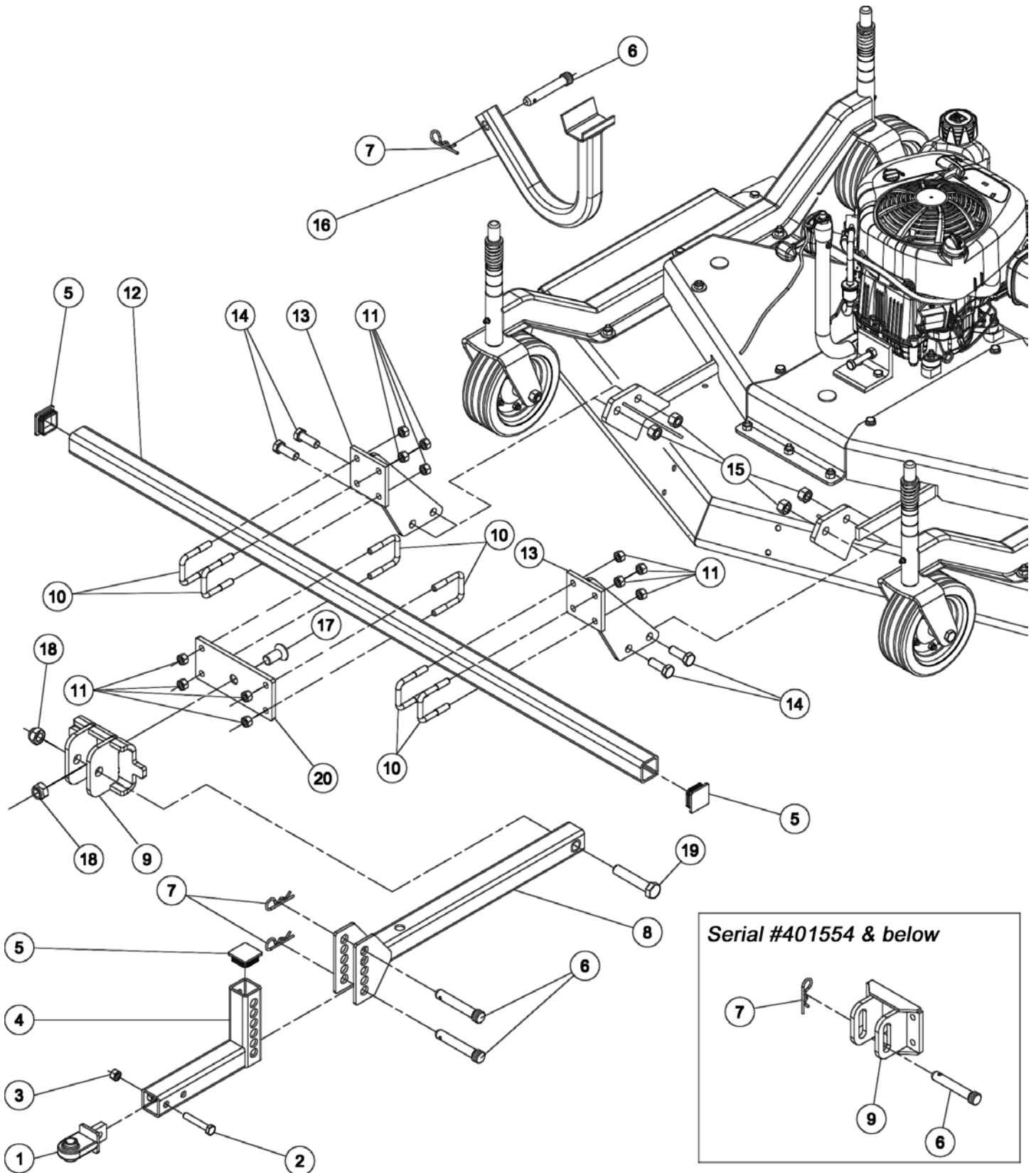

Ref.	Part #	Description	Qty.
1	000-8712	Ball joint	1
2	019-2236	Bolt HH M12-1.75x70 C8.8 Z P	1
3	001-3345	Nut ES M12-1.75 Z TK	1
4	000-8724	Hitch bracket	1
5	008-2760	Plastic cap 50 mm.	3
6	502-933B	Pin Ø19x140 Z	3
7	009-1507	Hairpin cotter Ø4 Z	3
8	000-8731	Drawbar, for rear mount	1
9	000-8741	Attachment bracket, drawbar; #401554 & below	1
	000-8735	Attachment bracket, drawbar; #401555 & above	1
10	000-8754	Bolt "U" M12-1.75x76x51 Z	6
11	009-4139	Nut ES M12-1.75 TN Z	12
12	000-8748	Offset bar	1
13	000-8750	Mounting bracket, offset bar	2
14	000-6578	Bolt HH M16-2.00x45 C8.8 Z F	4
15	000-5581	Nut PT M16-2.00 C6 Z TK	4
16	000-8780	Height adjustment stand	1
17	000-8715	Bolt CS M20-2.50x45 C10.9 Z F; #401555 & above	1
18	000-5507	Nut PT M20-2.50 C6 Z TK; #401555 & above	2
19	001-9291	Bolt HH M20-2.50x100 C8.8 Z P; #401555 & above	1
20	000-8728	Attachment plate, drawbar; #401555 & above	1

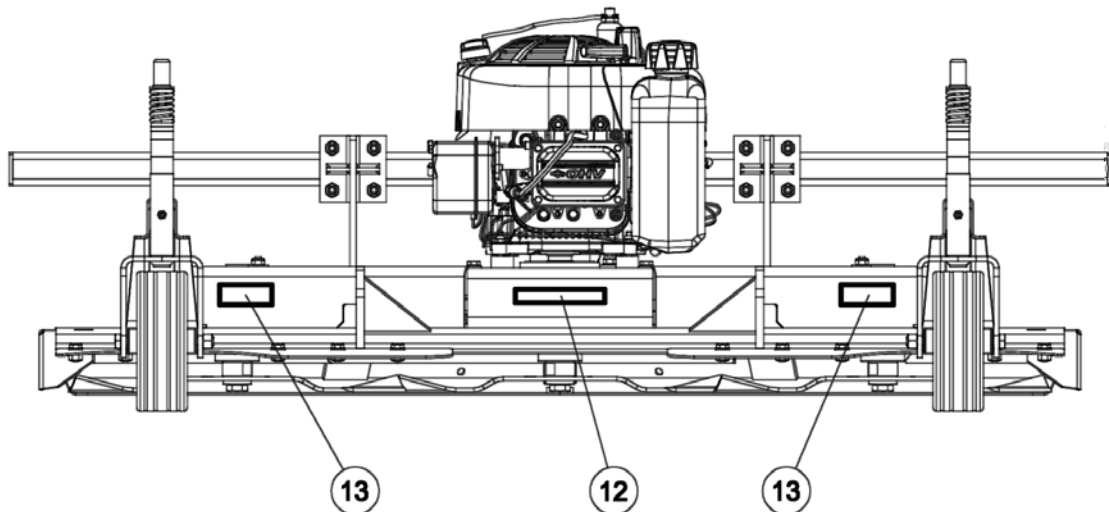
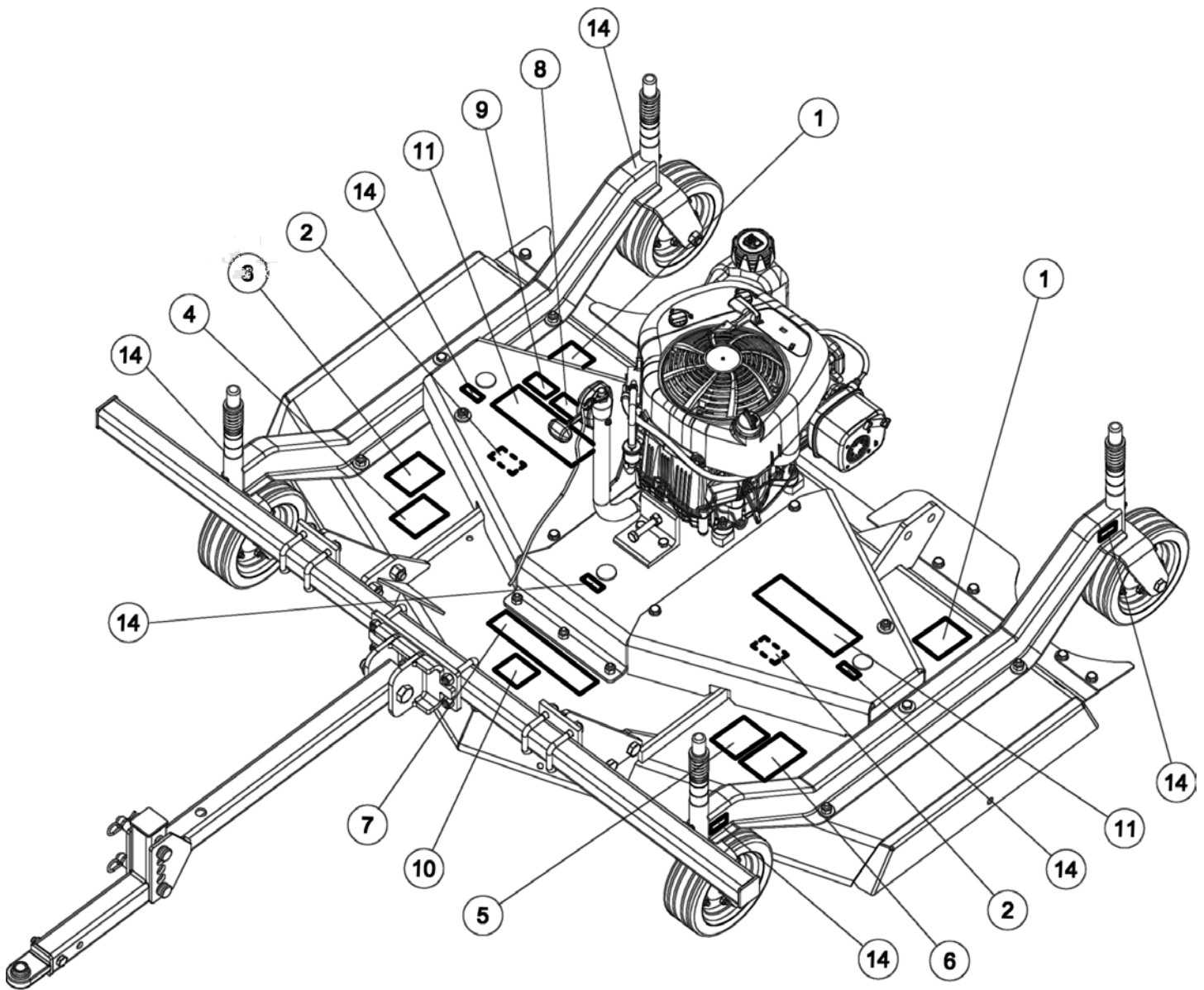

Ref.	Part #	Description	Qty.
1	950-818B	Decal "DANGER - Rotating blades; Thrown objects"	2
2	950-213B	Decal "DANGER - Replace shields", placed under belt shields	2
3	950-406B	Decal "WARNING - Falling off"	1
4	950-407B	Decal "WARNING - Crushing and pinching hazard"	1
5	950-191B	Decal "WARNING - Safety kill switch"	1
6	950-111B	Decal "CAUTION - To avoid serious injury"	1
7	950-298B	Decal "Cyclone"	1
8	950-234B	Decal "C30"	1
9	950-336B	Decal "CE5"	1
10	950-226B	Decal "B"	1
11	950-106B	Decal "BEFCO"	2
12	950-358B	Decal "Made in USA"	1
13	950-366B	Decal, red reflective	2
14	937-0194	Decal, "grease"	7
	960-395B	Operator's & Parts Manual "Cyclone C30-CE5H" #345293+	1

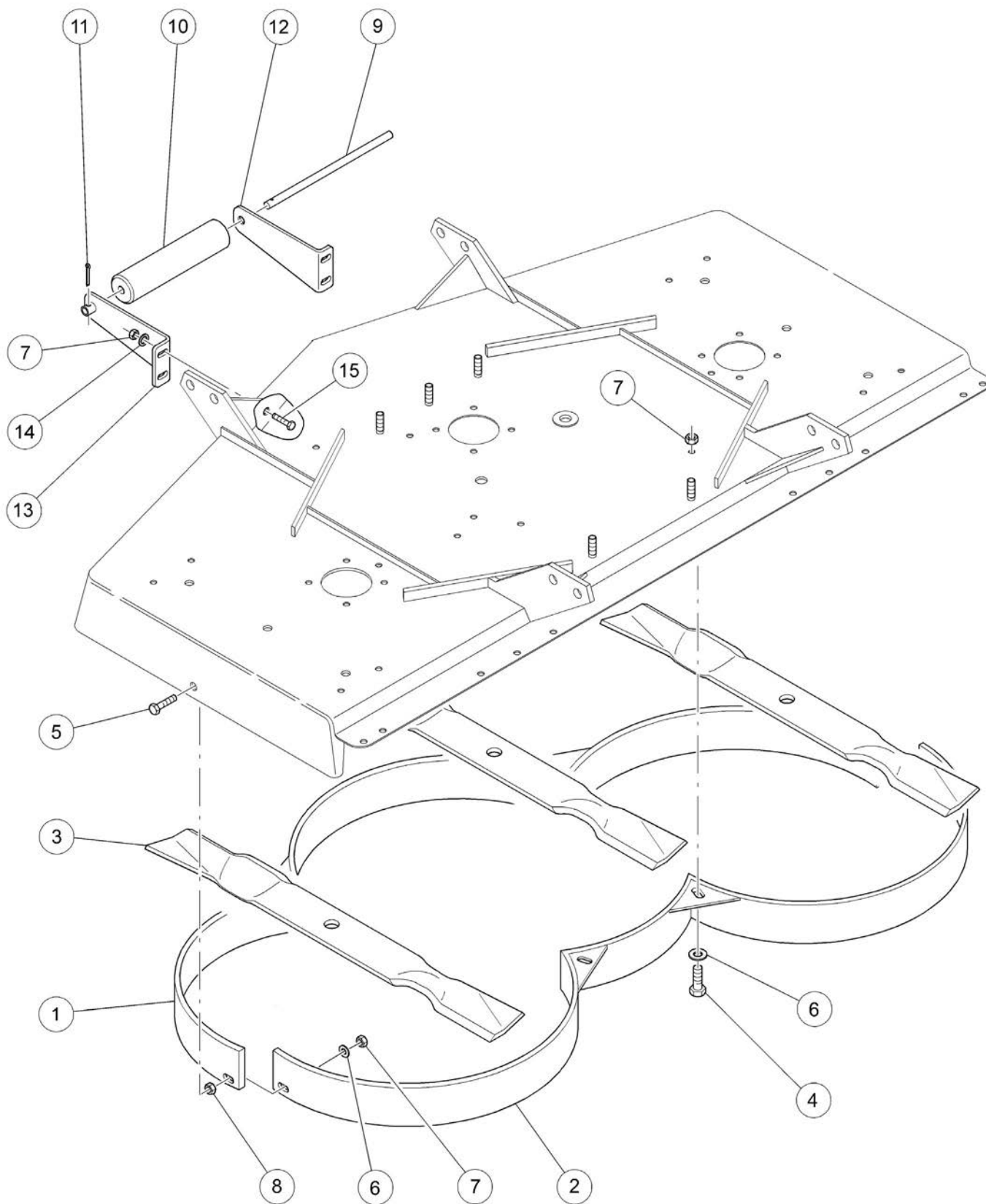

Ref.	Part #	Description	Qty.
1	011-5824	Baffling, front 60"	1
2	011-5825	Baffling, rear 60"	1
3	000-6641M	Mulching blade 60"	3
4	000-6349	Bolt HH M10-1.50x20 C8.8 Z F	5
5	009-1281	Bolt HH M10-1.50x35 C8.8 Z F	2
6	003-0157	Washer fender Ø10 Z	7
7	003-0156	Nut PT M10-1.50 C6 Z TK	11
8	000-3038	Nut HH M12-1.75 C6 Z TK	2
9	000-8929	Roller pin	1
10	006-7358	Front roller 3"	1
11	011-2087	Cotter pin Ø4x50 Z	1
12	000-8923	Roller support, right	1
13	020-8924	Roller support, left	1
14	000-2034	Washer flat Ø10 Z	4
15	003-3176	Bolt HH M10-1.50x25 C8.8 Z F	4
	001-600	Front roller, complete	-
	005-600	Mulching kit 60", complete	-

Use only original spare parts

All rights reserved. It is unlawful to copy, reprint or use any of the information or details in this manual without the expressed written permission of the Company. Technical information provided in this manual is approximate, the Company reserves the right to modify or improve the models shown for technical or commercial purposes. Pictures in this manual do not necessarily show the machine as delivered.

BEFCO[®]

P.O. Box 6036
Rocky Mount, NC 27802-6036
Tel.: 252.977.9920 - Fax: 252.977.9718
www.befco.com

