



# MBHVH2418F.3

**MODELS:**  
BHVH2418GX  
BHVH3018GX  
BHVH3018GXT  
BHVH3018GXS

<b>ITEM NUMBER:</b> _____  <b>SERIAL NUMBER:</b> _____
--

# Owner's Manual

## Instructions for Assembly, Testing, Operation, Servicing and Storage

**24 & 30 Ton Log Splitters:** Outdoor hydraulic powered machine that splits wood logs.

### **⚠ WARNING**

**READ and UNDERSTAND this manual completely before using log splitter.**

All operators of this equipment must read and completely understand all safety information, operating instructions, maintenance and storage instructions. Failure to properly operate and maintain the log splitter could result in serious injury to the operator and bystanders from moving parts that can crush or cut, flying objects, burns, fire or explosion, escaping high pressure hydraulic fluid, or carbon monoxide poisoning in particular, be aware of the following hazards.

#### Crush and Cut Hazards

Moving parts can crush and cut hands and fingers. Keep hands clear of endplate, wedge, logs, and log dislodger/strippers while splitting.

#### High Pressure Hydraulic Fluid Hazards

High fluid pressures and temperatures are developed in hydraulic log splitters. Hydraulic fluid escaping through even a pin-size hole opening can puncture skin and cause severe blood poisoning. Inspect hydraulic system regularly for possible leaks. Never check for leaks with your hand while the system is pressurized. Seek medical attention immediately if injured by escaping fluid.

#### Fire Hazards

- If your log splitter is intended for use near an ignitable forest, brush, or grassy covered land, the engine exhaust should be equipped with a spark arrestor. See the "Specifications" section of this manual to determine if your splitter already has a spark arrestor. If not equipped, call Iron & Oak Product Support for ordering information.
- Keep a class ABC fire extinguisher with you.

### **STOP!**

**ADD OIL TO ENGINE BEFORE USING:** Engine is shipped without oil. DO NOT start log splitter without first adding oil.

**ADD HYDRAULIC OIL:** Your log splitter was shipped without hydraulic oil. Refer to Periodic Maintenance section of this manual for instructions on filling the hydraulic reservoir

**PRIME THE PUMP:** The pump on your log splitter needs to be primed before use. Refer to Initial Setup section for instructions.

**INSPECT COMPONENTS:** Closely inspect to make sure no components are missing or damaged.

See Initial Unpacking and Set-up for instructions and for whom to contact to report missing or damaged parts.

**Any Questions, Comments, Problems or Parts Orders**  
*Call Iron & Oak Product Support 1-800-817-1005*

## Hazard Signal Word Definitions





	<p>This is the safety alert symbol. It is used to alert you to potential personal injury hazards. Obey all safety messages that follow this symbol to avoid possible injury or death.</p>
	<p>DANGER (red) indicates an imminently hazardous situation which, if not avoided, will result in death or serious injury.</p>
	<p>WARNING (orange) indicates a potentially hazardous situation which, if not avoided, could result in death or serious injury.</p>
	<p>CAUTION (yellow) indicates a potentially hazardous situation which, if not avoided, may result in minor or moderate injury.</p>
	<p>CAUTION (yellow) used without the safety alert symbol indicates a potentially hazardous situation which, if not avoided, may result in property damage.</p>

fig01453

# Table of Contents

Hazard Signal Word Definitions.....	2
Table of Contents.....	3
About Your Log Splitter.....	4
Safety Label Locations.....	5
Machine Component Identification.....	7
Initial Setup.....	8
Moving and Towing to the Job Site.....	10
Before Each Use – Inspection/Maintenance.....	14
Before Each Use – Fueling.....	17
Before Each Use – Work Site Selection and Set-Up.....	18
Splitting Operation.....	19
Storage.....	25
Periodic Maintenance.....	26
Troubleshooting.....	28
Specifications.....	29
Parts Breakdown – Exploded View – Rev E.....	30
Summary of Important Safety information for Operation.....	32
Assembly Instructions.....	37
Available Accessories.....	49
Limited Warranty.....	50
Product Registration.....	51
California Proposition 65 Information.....	52

# About Your Log Splitter

**Thank you for purchasing your Iron & Oak log splitter!**

## **About Your Log Splitter:**

This log splitter is a machine designed to split wood logs using a hydraulically powered moving wedge. The log splitter's gasoline engine is used to pressurize the hydraulic system.

This log splitter is designed to split logs *lengthwise with the grain only*.

This log splitter model is capable of splitting logs up to 24" long and 16" in diameter.

Your splitter can be used in either a vertical or horizontal splitting position:

- When the splitter is set up to operate in the horizontal splitting position, a log is placed on the horizontal beam and the wedge moves horizontally into the end of the log to split it.
- When the splitter is set up to operate in the vertical splitting position, the log is placed on the endplate, upright on its end, and the wedge moves down into the top of the log to split it.

The horizontal splitting position is used for lighter logs that can be easily loaded onto the beam. The vertical splitting position is used for heavier logs that are difficult to load onto the beam.

The technical specifications for your log splitter are provided in the Specifications section of this manual.

### **WARNING**

This log splitter uses a high-pressure hydraulic system to generate a very strong splitting force.

**Read the manual completely** before using the machine to understand how to safely operate and maintain it.

Follow all safety precautions presented throughout this manual. A summary of important safety information can be found at the end of this manual.

**Contact Iron & Oak Product Support at 1-800-817-1005 for any questions about the appropriate use of this log splitter and/or optional accessories.**

## **Warranty Registration:**

Please fill out and submit the warranty registration page at the end of the manual so that we have your contact information for any future product literature or replacement parts you may need. You can also register online at [www.ironandoak.com](http://www.ironandoak.com).

## **Attention: All Rental Companies and Private Owners who loan this equipment to others!**

All persons to whom you rent/loan the log splitter must have access to and read this manual. Keep this owner's manual with the splitter at all times and advise all persons who will operate the machine to read it. You must provide instruction on how to safely operate the splitter and remain available to answer any questions a renter/borrower might have.

# Safety Label Locations

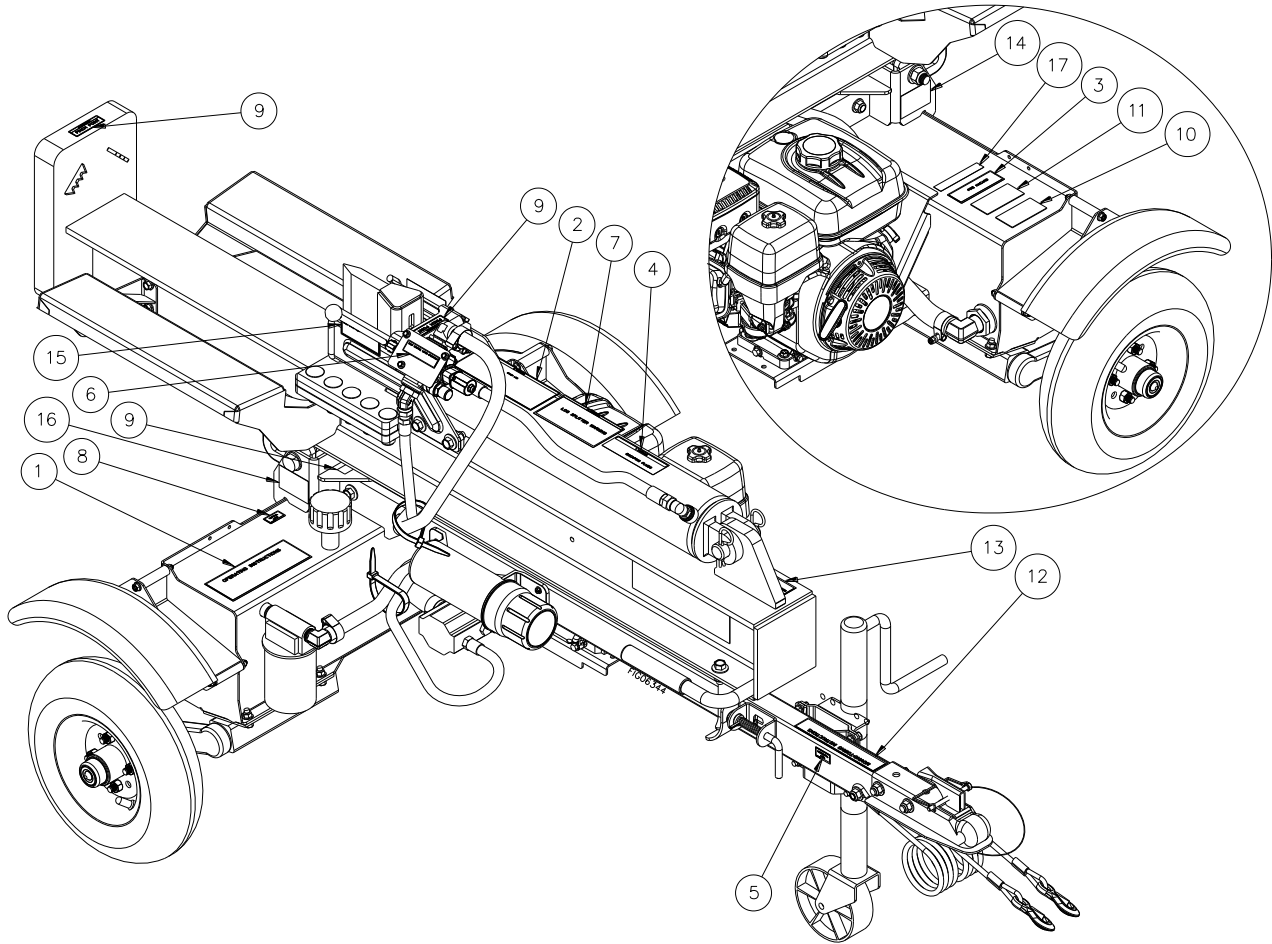

**Always make sure safety labels are in good condition.** If a safety label is missing or not legible, order new labels or unsafe operation could result. **Contact Iron & Oak Product Support at 1-800-817-1005.**

Ref#	Kit#	Part #	Description	Qty	Unit
1	799554	777887	Operation Instructions	1	All
2		777889	Stuck Log Warning	1	All
3		777890	Fire Hazard	1	All
4		777891	Escaping Fluid	1	All
5	N/A	778597	Horizontal Lock	1	All
6	799554	778609	Splitter Control	1	All
7		778610	Log Splitter Warning	1	All
8		778714	Vertical Lock	1	All
9		787944	Pinch Point Warning	3	All
10		788935	Fuel Fire Explosion	1	All
11		788937	Poisonous Gas	1	All
12	N/A	791105	Moving/Towing Instructions	1	BHVH2418GX, BHVH3018GX
		789236	Moving/Towing Instructions	1	BHVH3018GXT
13	N/A	791123	Max Towing Speed	1	BHVH2418GX, BHVH3018GX
14	799554	797158	Made in USA	1	All
15		798403	Log Dislodger Warning	2	All
16	N/A	---	Nameplate/Serial Number	1	All
17	799554	799546	Prop 65	1	All

# Safety Label Locations

1

### OPERATING INSTRUCTIONS

**GENERAL**

- Stay in the OPERATOR POSITION while actuating controls.
- Never actuate controls until the helper is 10ft away from log splitter, including any helpers assisting to load logs.
- Wear eye protection, hearing protection, snug fitting gloves, and safety shoes or heavy boots. No loose or dangling apparel.

**SETTING UP**

- Place log splitter on dry, level ground.
- Secure splitter for unintended movement.
- Place splitter in horizontal or vertical position.
- Start engine

**SPLITTING LOG**

- Position log on beam, against endplate.
- Move split control to extend wedge and split log.
- Release split control to stop wedge.
- Move split control to return wedge.
- Remove split wood from work area.

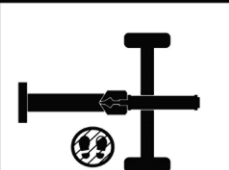

Operator Position - horizontal

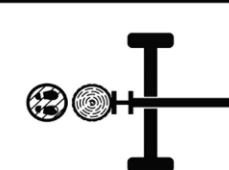

Operator Position - vertical

2

**WARNING**

**IF LOG BECOMES STUCK ON WEDGE**

A log can become stuck on the wedge if the wedge becomes embedded in the log and the log doesn't split and separate. This can happen if the log is too stringy or tough to split completely.

A stuck log will move back with the wedge on the initial attempt to retract the wedge. If this happens, STOP retracting the wedge immediately and follow the directions below. NEVER attempt to remove a stuck log by:

- Using the hydraulic force of the splitter
- Modifying the splitter
- Adding attachments to the splitter

Personal injury could result from log or metal pieces flying out at high speed toward the operator or bystanders, or the splitter could become damaged.

**ALWAYS** remove the log MANUALLY using the following procedure:

- If there is already 1" or more of clearance between the log and endplate, go to step 2. Otherwise, retract wedge just enough to remove pressure between the log and endplate - about 1" clearance.
- Turn engine OFF.
- Remove stuck log from the wedge manually with a pry bar or sledgehammer. Important: Be extremely careful as log pieces may fly off as they separate from the wedge. Wear safety goggles and make sure bystanders are clear.
- Do not attempt to respit a stuck log once it has been removed from the wedge.

3

**WARNING**

**FIRE HAZARD**

Hot exhaust can ignite dry brush, trees, or grass.

- Equip engine with a spark arrester if you will be using near ignitable forest, brush or grassy covered land.
- Keep a fire extinguisher on hand that is rated for ordinary combustibles & flammable liquids.

4

**WARNING**

**ESCAPING HIGH PRESSURE HYDRAULIC FLUID HAZARD**

High fluid pressures and temperatures are developed in the hydraulic system. Hydraulic fluid escaping through even a pin-size hole opening can puncture skin and cause blood poisoning.

- Inspect hydraulic system regularly for leaks
- Never check for leaks with your hand while system is pressurized.
- Seek medical attention immediately if injured by escaping fluid.

5

**HORIZONTAL LOCK**

8

**VERTICAL LOCK**

6

**SPLIT CONTROL LEVER OPERATION**

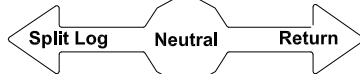

9

**WARNING**

**PINCH POINT**

Keep hands clear during operation.



7

**WARNING**

Moving parts can crush and cut. Pieces can fly out while splitting. Follow safety rules for operating the log splitter or serious injury could result.

- READ the Owner's Manual completely before operating.
- Only one person should operate the log splitter. If an assistant is helping to load logs, the operator should not actuate controls until the assistant is at least 10 ft away.
- Stay in the designated OPERATOR POSITION while actuating the controls.
- Split wood in direction of the grain only.
- Hold bark side of logs when loading.
- Keep hands away from wedge, endplate/ram, and partly split logs.
- Never leave log splitter unattended during operation.
- Stay off slopes and slippery surfaces.

See additional safety rules in the Owner's Manual.

10

**WARNING**

**Fuel Fire/Explosion Hazard**

Fuel is flammable and explosive.

- Never fuel a running or hot engine.
- Clean up fuel spills immediately.
- Ensure there are no fuel leaks before starting.
- Keep sources of sparks and flames away.
- Hot exhaust may also ignite spilled fuel.
- No Smoking.
- Keep a fire extinguisher nearby.

11

**WARNING**

**Poisonous Gas**

This product gives off carbon monoxide, a poisonous gas that can kill you. You CANNOT smell it, see it, or taste it.

- ONLY use outside & far away from windows, doors, & vents.
- NEVER use inside homes, garages, or sheds, EVEN if you run a fan or open doors or windows.

See owner's manual for more details.

12

**MOVING/TOWING INSTRUCTIONS**

**Moving log splitter by hand:**

- Lock beam in horizontal position (tip-up models only).
- Lock towbar leg or jack stand in DOWN position.
- Lock support leg in UP position (if equipped)
- Do not attempt to move log splitter up or down slope by hand.

**Towing log splitter:**

- Latch coupler securely to class 2 or higher hitch with 2" ball.
- Lock towbar leg/jack stand or support leg (if equipped) in the UP position.
- Attach safety chains to tow vehicle.
- Close fuel shut-off valve on engine (if equipped)
- Do not tow faster than 45 mph. Higher speeds can cause loss of control.
- Check local, state, and federal requirements before towing on public roads.

13

**MAX TOWING SPEED**

**45 MPH**

14

**made in the USA**



with US and imported components

15

**LOG STRIPPER**

**RETRACT WEDGE TO REMOVE STUCK WOOD**

**WARNING**

**PINCH POINT**

Keep hands clear of wedge and log stripper



17

**WARNING:** This product can expose you to chemicals including soots, tars, and mineral oils, which are known to the State of California to cause cancer, and carbon monoxide, which is known to the State of California to cause birth defects or other reproductive harm. For more information go to [www.P65Warnings.ca.gov](http://www.P65Warnings.ca.gov).

# Machine Component Identification

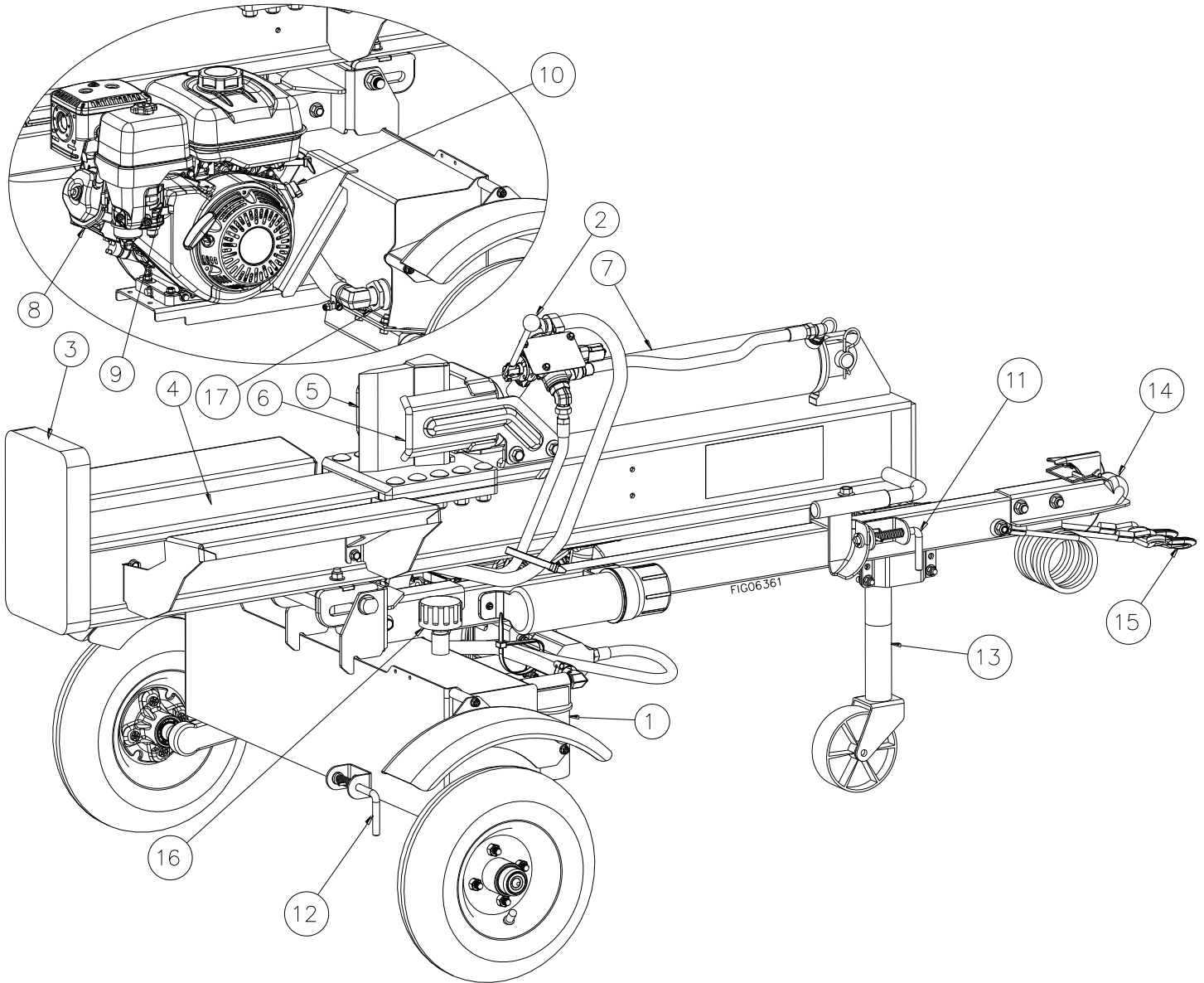

Ref #	Description
1	Return Line Filter
2	Split Control Lever
3	End Plate
4	Beam
5	Wedge
6	Log Dislodger
7	Cylinder
8	Engine
9	Fuel On/Off

Ref #	Description
10	Engine On/Off
11	Horizontal Lock
12	Vertical Lock
13	Jack
14	2" Ball Coupler
15	Safety Cables
16	Hydraulic Reservoir Cap
17	Suction Strainer

# Initial Setup

## IMPORTANT!

Engine is shipped without oil. DO NOT start the engine before adding oil.

See Assembly Instructions section of this manual on page 37 to assemble the log splitter before setup.

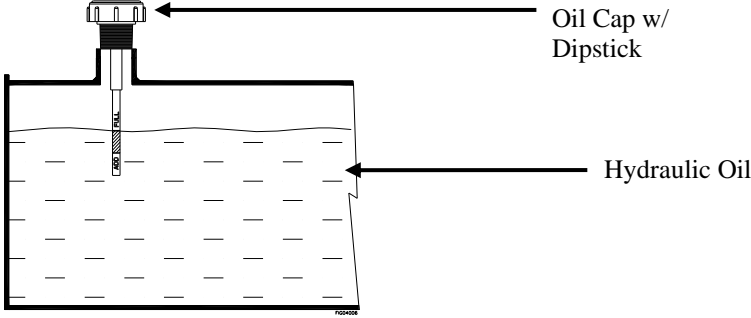
<p><b>Step One:</b> <b>Inspect Log Splitter Components</b></p>	<p><b>Closely inspect all log splitter components.</b> (See Machine Components section of this manual for diagram of components.)</p> <ul style="list-style-type: none"><li>• If you have missing or damaged components, please contact Product Support at 1-800-817-1005.</li></ul>
<p><b>Step Two:</b> <b>Add Oil to Engine</b></p>	<p><b>Add oil to the engine.</b> Using a funnel, add SAE 10W-30 oil up to the FULL mark on the dipstick. (See engine Owner's Manual for oil capacity and location of fill cap.)</p>
<p><b>Step Three:</b> <b>Add Hydraulic Oil to Reservoir</b></p>	<p><b>⚠ WARNING:</b> High fluid pressures and temperatures are developed in hydraulic log splitters. Hydraulic fluid escaping through a pin-hole sized opening can burn or puncture skin, resulting in wounds that could cause blood poisoning, infection, disability, gangrene, amputation, or death. Therefore, the following instructions should be heeded at all times when inspecting or servicing the hydraulic components of the log splitter.</p> <ul style="list-style-type: none"><li>• NEVER check for leaks with your hand. Leaks can be located by holding a piece of cardboard or wood (at least two feet long) with your hand at one end and passing the other end near the suspected area (wear eye protection). Look for discoloration of the cardboard or wood.</li><li>• NEVER adjust the pressure of the pump or valve.</li><li>• If injured by escaping fluid, no matter how small the wound is, see a doctor at once. A typical injection injury may be a small wound that does not look serious. However, severe infection or reaction can result if proper medical treatment is not administered immediately by a doctor who is familiar with injection injuries.</li></ul> <ol style="list-style-type: none"><li>1. Remove hydraulic oil dipstick.</li><li>2. Refer to the <b>Specifications</b> section for approximate hydraulic oil capacity.</li><li>3. Fill reservoir with 10wt AW32, ASLE H-150, or ISO 32 oil. Use a funnel.</li><li>4. Replace hydraulic oil dipstick and check that oil level is between the marks on the dipstick. Note: Do not thread in dipstick when checking oil level.</li></ol>  <p>The diagram shows a cross-section of a rectangular hydraulic oil reservoir. At the top center, there is a dipstick with a handle labeled "Oil Cap w/ Dipstick". The dipstick is partially submerged in the oil. The oil level is indicated by a horizontal line. To the right of the reservoir, there is a label "Hydraulic Oil" with an arrow pointing to the oil. The reservoir is filled with a grid of horizontal lines representing the oil.</p>

# Initial Setup

## **Step Three: Add Hydraulic Oil to Reservoir (continued)**

5. Disconnect the spark plug wire from the spark plug. This prevents the engine from starting until the hydraulic pump and cylinder are completely filled with oil. Make sure the spark plug wire is held away from the spark plug with string or other nonconductive material.
6. Push the valve control handle with one hand to the forward (extend) position (towards the front of the cylinder). Pull on the starter grip recoil at least 20 times so that hydraulic fluid has cycled through the pump.
7. Reconnect the spark plug wire to the spark plug.
8. Start engine and use control valve handle to extend and retract wedge five (5) times to remove air from the high pressure lines.
9. With wedge retracted, shut off engine.
10. Check oil level again. Fill if necessary.
11. Replace hydraulic oil fill/vent cap.

**⚠ WARNING:** NEVER remove the hydraulic oil fill cap when the engine is running or hot. Hot oil can escape causing severe burns. Allow log splitter to cool completely before removing hydraulic oil fill cap.

**Note:** If the log splitter will be run for long periods of time in outdoor temperatures above 70°F, we recommend changing the hydraulic oil to DEXRON III.

## **Step Four: Lubricate Beam**

**Lubricate the surface of the beam with grease.** This will help prevent wear between the wedge keepers and the beam.

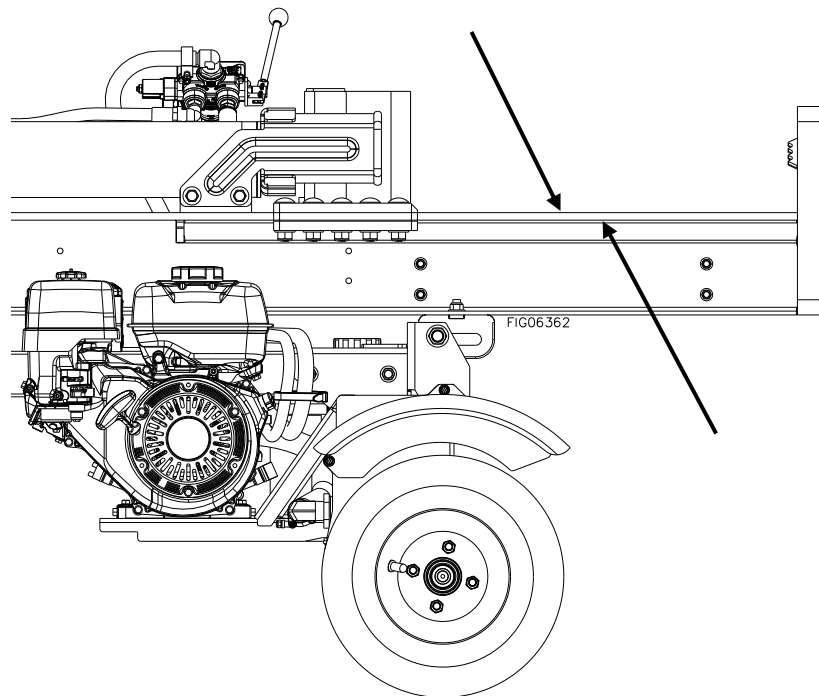

Apply grease to the top of the beam and underneath the edge of the beam, where the wear pads travel.

# Moving and Towing to the Job Site

## **⚠️ WARNING**

The log splitter is heavy. It can crush and cause serious injury if it rolls out of control or tips over.

Follow the instructions below for safely moving and towing the log splitter.

### Moving the log splitter:

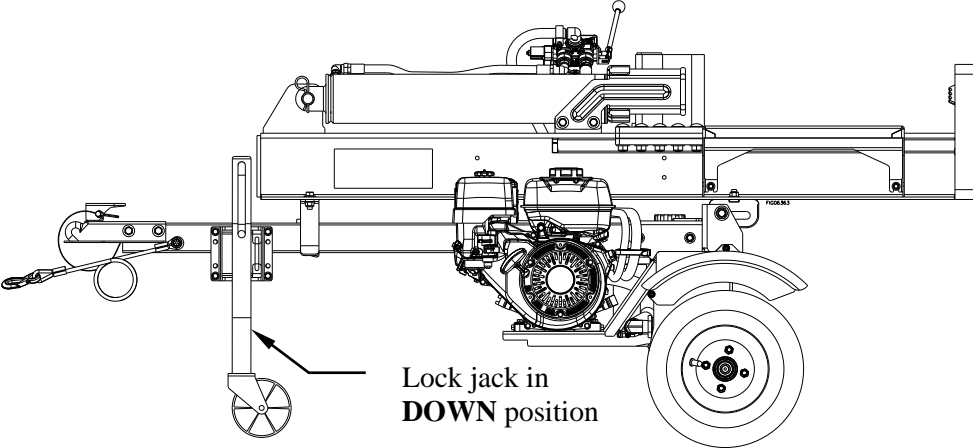
<p><b>1. Place in Horizontal Position</b></p>	<p><b>Make sure the log splitter is locked in the horizontal position with horizontal latch before moving.</b> NEVER move log splitter when it is in vertical configuration because it will be unstable and could tip.</p>
<p><b>2. Engine Off</b></p>	<p><b>IMPORTANT: Make sure log splitter engine is off.</b> Never move the log splitter with its engine running.</p>
<p><b>3. Fuel Valve Off (if equipped)</b></p>	<p><b>Turn fuel valve off</b> to prevent carburetor flooding and reduce the chance of fuel leakage. Refer to Engine owner's manual for fuel valve location.</p>
<p><b>4. Lock Jack DOWN</b></p>	<p><b>Lock jack in DOWN position</b> before you move the log splitter.</p> 
<p><b>5. Move Log Splitter to Work Site or Tow Hitch</b></p>	<p><b>Move log splitter by hand either directly to chosen work site or to vehicle hitch for towing.</b> (See Step Three: Before Each Use - Work Site Selection and Set-Up) <u>Important Safety Instructions:</u></p> <ul style="list-style-type: none"> <li>• <b>Hills.</b> Do not move the log splitter up or down hills by hand—use a towing vehicle.</li> <li>• <b>No riding.</b> Never allow anyone to sit or ride on the log splitter.</li> <li>• <b>No cargo.</b> Never transport cargo or wood on the log splitter.</li> </ul>

# Moving and Towing to the Job Site

## Towing:

<b>1. Read Instructions</b>	Review towing safety instructions in your vehicle manual.
<b>2. Check Tires</b>	Make sure tires are fully inflated and in good repair. <b>⚠️ WARNING:</b> <ul style="list-style-type: none"><li>• Do not over-inflate tires. Serious injury can occur if tire explodes.</li><li>• When seating a bead after repair, do not exceed 60 PSI. Pressures higher than 60 PSI can cause the tire and wheel to rupture and explode.</li></ul>
<b>3. Engine Off</b>	<b>IMPORTANT: Make sure log splitter engine is off.</b> Never move the log splitter with its engine running.
<b>4. Fuel Valve Off (if equipped)</b>	<b>Turn fuel valve off</b> to prevent carburetor flooding and reduce the chance of fuel leakage. Refer to Engine owner's manual for fuel valve location.

# Moving and Towing to the Job Site

## 5. Attach to Hitch (2" ball)

### Attach log splitter to vehicle hitch.

1. Attach log splitter's coupler to a class 2 or higher hitch with 2" ball (only).
2. Adjust coupler to ball by raising locking lever and turning lock nut with wrench.
3. Proper adjustment is obtained when coupler is as tight as possible on ball and locking lever can still be opened and closed.
4. Lock lever closed to secure the attachment.

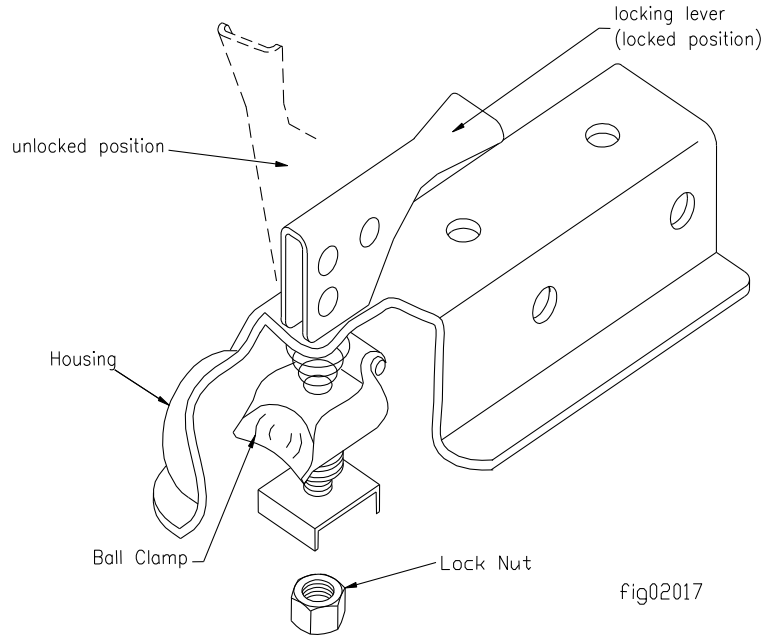

5. Insert pin into locking lever to ensure it does not unlock while towing.

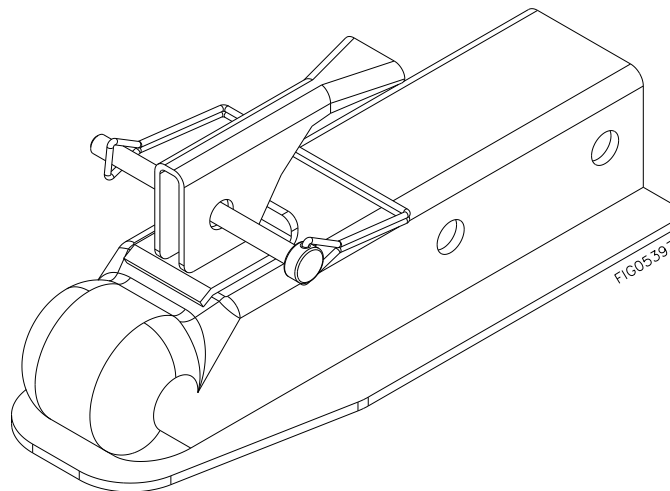

## 6. Attach Safety Cables

### Attach safety cables.

1. Two safety cables must be used while towing.
2. Cross safety cables under the coupler allowing only enough slack for vehicle turns.

# Moving and Towing to the Job Site

## 7. Lock Jack UP

To provide adequate ground clearance while towing, secure the jack in the UP position.

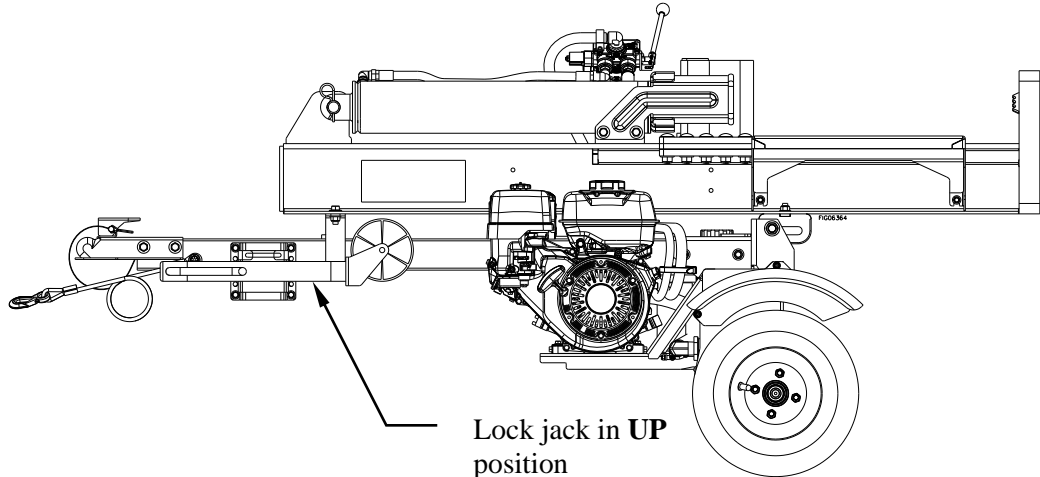

## 8. Tow to Desired Location

Tow log splitter carefully to desired work site.

(See Step Three: Before Each Use – Work Site Selection and Set-Up)

### Important safety instructions:

- **Added length.** Be aware of the added length of the splitter.
- **Speed limit.** Never tow the BHVH2418GX or BHVH3018GX log splitter over 45 mph. Road conditions permitting, the BHVH3018GXT may be towed at up to 55 mph. Faster speeds may result in loss of control.
- **Rough terrain.** Drive slowly and take extra caution when traveling over rough terrain.
- **On public roads.** If towing on a public road, make sure to comply with all local, state, and federal towing requirements. It is the sole responsibility of the purchaser to obtain licensing, trailer lights, safety chains or signage, as needed to comply.
- **Unattended.** Turn off the towing vehicle before leaving the splitter unattended.
- **Under the influence.** Never tow or operate this splitter while under the influence of alcohol, drugs, or medication.

## 9. Lock jack DOWN and Unhitch

**Lock jack in the DOWN position and disconnect from vehicle.**

NEVER operate log splitter while it is attached to the vehicle.

1. Lock the jack down and open the coupler latch assembly.
2. Unhitch from vehicle.

# Before Each Use – Inspection/Maintenance

## **Step One: Inspect and maintain log splitter before each use**

If the log splitter has been used previously, it must be inspected and maintained BEFORE EACH SUBSEQUENT USE.

### ⚠ WARNING

ALWAYS shut off the engine, disconnect the spark plug, and relieve system pressure before inspecting, cleaning, adjusting, or repairing the splitter. Relieve system pressure by moving Split Control Lever back and forth several times.

### **IMPORTANT:**

If a part needs replacement, only use parts that meet the manufacturer's specifications. Replacement parts that do not meet specifications may result in a safety hazard or poor operation of the log splitter.

<b>1. Engine Off / Relieve Pressure</b>	<p><b>Perform all inspections/repairs with the engine off and hydraulic system pressure relieved.</b></p> <ol style="list-style-type: none"> <li>1. Make sure engine is off and cool.</li> <li>2. Disconnect the spark plug.</li> <li>3. Relieve all hydraulic system pressure by moving the Split Control Lever back and forth several times.</li> </ol>
<b>2. Remove Debris</b>	<p><b>Remove debris from engine, muffler, and moving parts.</b></p> <ol style="list-style-type: none"> <li>1. <u>Engine debris:</u> Debris on a hot engine can be a fire hazard. Clean debris and chaff from engine cylinder head, cylinder head fins, fan housing/recoil starter, and muffler areas. Avoid contact with hot muffler.</li> <li>2. <u>Other debris:</u> Debris on moving parts can cause excess wear. Clear debris from the beam, wedge, log dislodger, and endplate.</li> </ol>
<b>3. Fuel Tank / Lines</b>	<p><b>Check fuel tank and fuel lines for leaks.</b></p> <p>Any fuel leak is a fire hazard. Fix any fuel leaks before starting engine.</p>
<b>4. Mechanical Parts</b>	<p><b>Check to be sure that all nuts and bolts are tight</b> to ensure the log splitter is in safe working condition.</p>

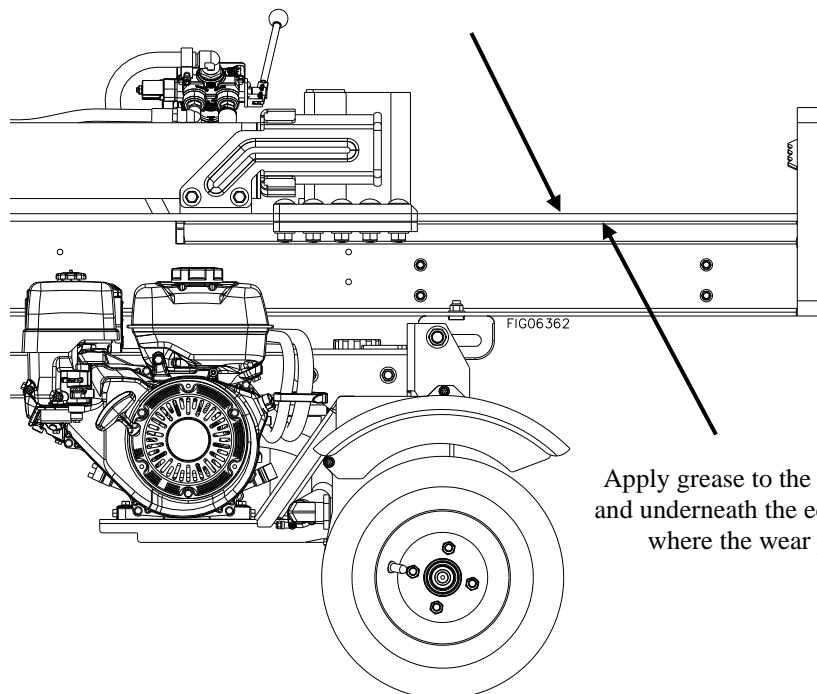

Apply grease to the top of the beam and underneath the edge of the beam, where the wear pads travel.

# Before Each Use – Inspection/Maintenance

## 5. Hydraulic System

### Check the hydraulic system carefully:

1. Visually inspect all hoses, tubing, clamps/fittings, pump, and cylinder for cracks, fraying, kinks, or other damage.
2. Check all components for oily residue, which may indicate a leak.

Do NOT operate the log splitter if there is any indication of damage or oily residue. Small leaks in hydraulic lines can cause severe injuries and can also be an indication of catastrophic failure in the near future. The life of hydraulic hoses may be from a few months to a few years, depending on use and storage patterns.

**⚠ WARNING:** High fluid pressures and temperatures are developed in hydraulic log splitters. Hydraulic fluid escaping through a pin-hole sized opening can burn or puncture skin, resulting in wounds that could cause blood poisoning, infection, disability, gangrene, amputation, or death. Therefore, the following instructions should be heeded at all times when inspecting or servicing the hydraulic components of the log splitter:

- Stop the engine, disconnect the spark plug, and move all control valve handles back and forth to relieve pressure before changing or adjusting hydraulic system components such as hoses, tubing, fittings, or other components.
- NEVER check for leaks with your hand. Leaks can be located by holding a piece of cardboard or wood (at least two feet long) with your hand at one end and passing the other end near the suspected area (wear eye protection). Look for discoloration of the cardboard or wood.
- NEVER adjust the pressure setting of the pump or valve.
- If injured by escaping fluid, no matter how small the wound, see a doctor at once. A typical injection injury may be a small puncture wound that does not look serious. However, severe infection or reaction can result if proper medical treatment is not administered immediately by a doctor familiar with injection injuries.

## 6. Hydraulic Oil Level

**Check the hydraulic oil level.** Fill as needed – check that oil level is between the marks on the dipstick. Note: Do not thread in dipstick when checking oil level.

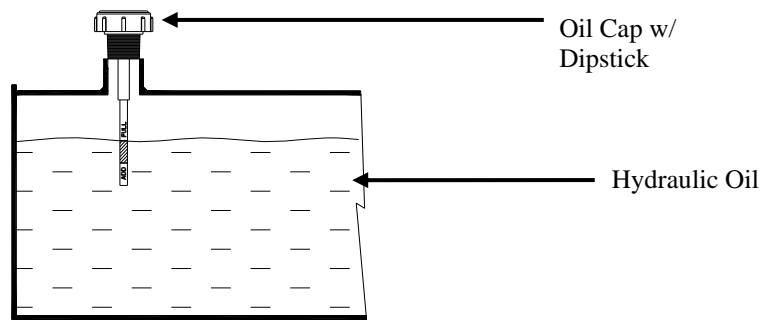

**⚠ WARNING:** NEVER remove the hydraulic oil fill cap when the engine is running or hot. Hot oil can escape causing severe burns. Allow log splitter to cool completely before removing hydraulic oil fill cap.

## 7. Engine

**Inspect and perform engine maintenance as directed in the engine manual.**

## Before Each Use – Inspection/Maintenance

<b>8. Spark Arrestor Muffler</b>	<b>If the engine is equipped with a spark arrestor muffler, clean and inspect it regularly (follow spark arrestor manufacturer's service instructions).</b> Replace if damaged.
<b>9. Tires</b>	<b>Make sure tires are fully inflated and in good repair if you will be towing the splitter.</b> See tire sidewall for recommended tire pressure.  <b> WARNING:</b> <ul style="list-style-type: none"><li>• Do not over-inflate tires. Serious injury can occur if tire explodes.</li><li>• When seating a bead after repair, do not exceed 60 PSI. Pressures higher than 60 PSI can cause the tire and wheel to rupture and explode.</li></ul>
<b>10. Shields / Guards</b>	<b>Replace all guards and shields after servicing the log splitter.</b>

# Before Each Use – Fueling

## Step Two: Fueling

### ⚠ WARNING

Gasoline is highly flammable and explosive. You can be burned or seriously injured when handling fuel. Use extreme care when handling gasoline.

<b>1. Engine Off and Cool</b>	<p><b>The engine must be off and allowed to cool at least two minutes before adding fuel.</b></p> <p><b>⚠ WARNING:</b> A running engine is hot enough to ignite fuel. Never add fuel or remove gas cap if engine is running or still hot.</p>
<b>2. Outdoor Location</b>	<p><b>Fill fuel tank outdoors – never indoors.</b></p> <p><b>⚠ WARNING:</b> Gasoline vapors can ignite if they collect inside an enclosure. Explosion can result.</p>
<b>3. Remove Gas Cap</b>	<p><b>Remove engine gas cap.</b></p>
<b>4. Add Gasoline</b>	<p><b>Add gasoline through fill opening from a UL listed container.</b></p> <p><b><u>Important Safety Instructions:</u></b></p> <ul style="list-style-type: none"> <li>• <b>Use approved container.</b> NEVER pump fuel directly into engine at gas station. Static charge can build and ignite fuel. Use a UL listed fuel container to transfer gas to the engine.</li> <li>• <b>Don't overfill.</b> DO NOT overfill the gas tank. Allow at least 1/2" of empty space below the fill neck to allow for fuel expansion</li> <li>• <b>Heat / flames / sparks.</b> Stay away from sources of heat, flame, or sparks while adding fuel.</li> </ul>
<b>5. Spills / Splashes</b>	<p><b>Clean up fuel spills /splashes immediately.</b></p> <ol style="list-style-type: none"> <li>1. Move the log splitter away from spilled fuel on the ground.</li> <li>2. Wipe fuel off engine and wait 5 minutes for excess fuel to evaporate before starting engine.</li> <li>3. Gas soaked rags are flammable and should be disposed of properly.</li> <li>4. If gasoline is spilled on your skin or clothes, change clothes and wash skin immediately.</li> </ol>
<b>6. Replace Gas Cap</b>	<p><b>Replace gas cap securely before starting engine.</b></p>
<b>7. Gasoline Storage</b>	<p><b>Store extra gasoline in a cool, dry place in a UL listed, tightly sealed container.</b></p>



# Before Each Use – Work Site Selection and Set-Up

## Step Three: Work site selection and log splitter setup

### **WARNING**

It is important to select an appropriate work site and properly set up the log splitter in order to minimize the risk of slips and falls, equipment rolling or tipping over, carbon monoxide poisoning, and accidental fires.

#### 1. Select Location

**Select an appropriate location for operating the log splitter. Inspect worksite for possible hazards before each use.**

Requirements:

1. Dry-level surface with good footing. Stay clear of areas with mud, ice, tall grass, weeds, brush, or snow.
2. Outdoors, away from air intakes.

 **WARNING:** The running engine gives off carbon monoxide, a poisonous gas that can kill you. You CANNOT smell it, see it, or taste it.

- ONLY run log splitter OUTDOORS and away from air intakes. NEVER run log splitter inside homes, garages, sheds, or other buildings or semi-enclosed spaces. These spaces can trap poisonous gases, EVEN if you run a fan or open windows.
- If you start to feel sick, dizzy, or weak while using the log splitter, shut off the engine and get to fresh air RIGHT AWAY. See a doctor. You may have carbon monoxide poisoning.

#### 2. Fire Precautions

**Take the following precautions against fire:**

1. **IMPORTANT:** If your splitter will be used near any unimproved forest, brush, or grassy covered land, then engine must be equipped with a spark arrestor.

(See the "Specifications" section of this manual to determine if your splitter already has a spark arrestor. Contact Iron & Oak Product Support at 1-800-817-1005 for information about obtaining a spark arrestor for your log splitter if it is unequipped.)

2. Make sure you comply with applicable local, state, and federal codes.
3. Keep a class ABC fire extinguisher available as a precautionary measure when operating the log splitter in dry areas.

#### 3. Position Splitter

**Position muffler at least 7 ft. from combustible or flammable objects during operation.** Hot exhaust fumes from engine could cause fire. Also, hydraulic oil leaking or spraying on hot engine can ignite.

#### 4. Lock Jack DOWN

**Lock the jack in the DOWN position.**

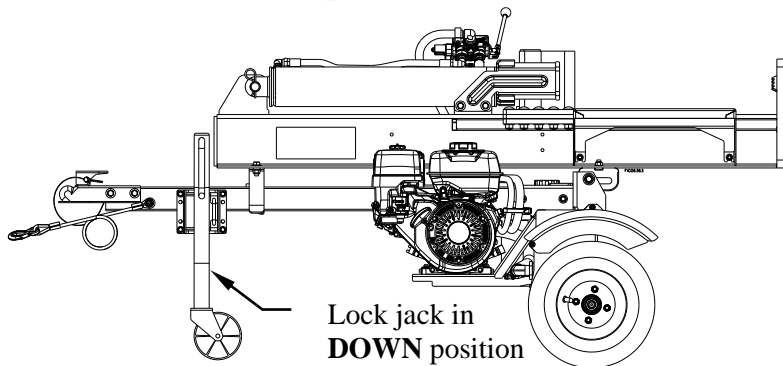

#### 5. Block Wheels

**Block the wheels to prevent unintended movement of the log splitter.**

#### 6. Apply grease

**Apply grease to beam where the wedge travels.**

# Splitting Operation

## WARNING

Before starting this log splitter, review the following instructions and safety information for safe operation of the log splitter.

Failure to follow these rules may result in serious injury to the operator or bystanders from moving parts that crush, cut, or entangle from flying objects, burns, fire, falling or tripping, or from carbon monoxide poisoning.

### General Safety Information:

- **Read manual.** Do not allow anyone to operate the log splitter who has not read the Owner's Manual or has not been instructed on the safe use of the splitter. The log splitter owner should instruct all operators in safe log splitter operation.
- **Age restrictions.** Never allow anyone under 16 years old to operate the log splitter. Anyone 16 years and older must be trained and supervised by a trained adult.
- **Intended use.** Log splitters should only be used for splitting wood logs, lengthwise with the grain. Do not use for other purposes as unforeseen hazards may result.
- **Modifications.** Never modify or alter the log splitter in any way. Modifications can create serious safety hazards and will void the warranty.
- **Attachments.** Never add attachments to the splitter, except for authorized accessories supplied by the manufacturer with instructions for safe installation and use.
- **Engine speed.** The maximum engine speed is preset at a safe limit. Never attempt to modify the engine speed setting to run at a higher speed.
- **Fuel/exhaust system.** NEVER modify or add to the exhaust system, fuel tanks, or fuel lines. Fire can result.
- **Remote control.** NEVER attach a rope, cable, or other remote device to the splitting control.
- **Splitting wedge.** NEVER attempt to change the height or speed of the splitting wedge.
- **Pressure setting.** NEVER increase the pressure setting of the pump or control valve.
- **Safety equipment / controls.** Always operate the log splitter with all safety equipment in place and in good working order, and all controls properly adjusted for safe operation.
- **Know how to stop.** Be thoroughly familiar with all controls and with the proper use of the equipment. Know how to stop the log splitter and relieve system pressures quickly if needed.
- **Operating speed.** Always operate the log splitter at the manufacturer's recommended speed. The maximum speed of the engine pump and wedge are preset within safe limits.
- **Daylight only.** Only use the log splitter in daylight so you can see what you are doing.
- **Smoking / sparks.** Never smoke while operating the log splitter, and never operate near sources of sparks or flames.
- **Under the influence.** Never operate, or let anyone else operate, the log splitter while under the influence of alcohol, drugs, or medication.
- **Unattended.** Never leave the machine unattended while the engine is running.
- **Refueling.** Never refuel the engine until it has cooled at least two minutes.
- **Adjusting / repairing.** Always make sure the engine is off before cleaning, repairing or adjusting the splitter, except as recommended by the manufacturer. In addition, disconnect the spark plug and move all control handles back and forth to relieve system pressure *before changing or adjusting hydraulic system components* such as hoses, tubing, fittings or other components.
- **Replace labels.** Always make sure safety labels are in place and in good condition. If a safety label is missing or not legible, order new labels because unsafe operation can result. Call 1-800-817-1005 to order new safety labels.

# Splitting Operation

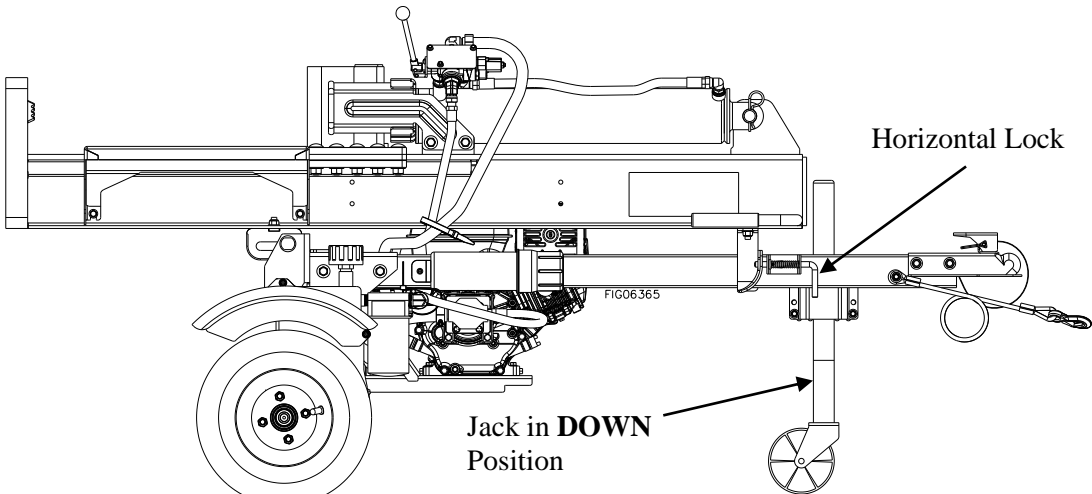
<p><b>1. Put on Protective Clothing / Gear</b></p>	<p><b>Wear the following protective clothing and safety gear:</b></p> <ol style="list-style-type: none"> <li><b>1. Eye protection.</b> Always wear safety glasses or goggles when operating the machine. Pieces of log may fly out and serious eye injury can occur.</li> <li><b>2. Boots.</b> Falling logs can crush feet. Always wear safety shoes or heavy boots when operating or helping to load logs.</li> <li><b>3. Gloves.</b> Wear snug fitting gloves without drawstrings or loose cuffs.</li> <li><b>4. Hearing protection.</b> The use of earplugs or other hearing protection device is recommended.</li> <li><b>5. No loose/dangling apparel.</b> Loose or dangling apparel can become entangled in moving parts. Never wear jewelry or loose-fitting clothing.</li> </ol>
<p><b>2. Lock and Block</b></p>	<p><b>Block the wheels to prevent unintended movement of the log splitter. Check that:</b></p> <ol style="list-style-type: none"> <li>The jack is locked in the DOWN position.</li> <li>The wheels are blocked.</li> </ol>
<p><b>3. Set to Horizontal or Vertical:</b></p> <p>a) <i>Set to <u>Horizontal Position</u></i></p>	<p><b>Set log splitter into either the horizontal or vertical splitting position.</b></p> <p>The <u>HORIZONTAL</u> splitting position is used for lighter logs that can be easily loaded onto the beam. The <u>VERTICAL</u> splitting position is used for light logs as well as heavy logs that are difficult to load onto the beam.</p> <p><b>Note:</b></p> <p>Musculoskeletal injury can result from lifting logs onto the log splitter if proper lifting techniques are not used or the logs are too heavy for a person's size, weight, or strength. In some cases, logs as small as 8" in diameter and 14" in length may be heavier than what some persons should be repeatedly lifting onto the splitter.</p> <p>The use of the vertical splitting position can greatly reduce the need to lift logs onto the splitter. Employers are advised to consider NIOSH lifting guidelines when assigning employees to log splitting tasks for an extended period of time.</p> <p><b>⚠ WARNING: NEVER</b> change splitting positions with the engine running. You may contact the muffler and receive serious burns.</p> <p><b>Make sure beam is locked securely in the horizontal position by checking the horizontal lock. Jack must be locked in the down position.</b></p> <p style="text-align: center;"><i>Horizontal Splitting Position</i></p> 

# Splitting Operation

b) Set to  
Vertical  
Position

1. Pull out horizontal lock pin, grasp lifting handle and lift beam until it rotates into vertical position.

**⚠ WARNING:** Crush hazard. The beam is heavy – do not let it just drop. It could crush fingers or cause damage to the splitter.

Vertical Splitting Position

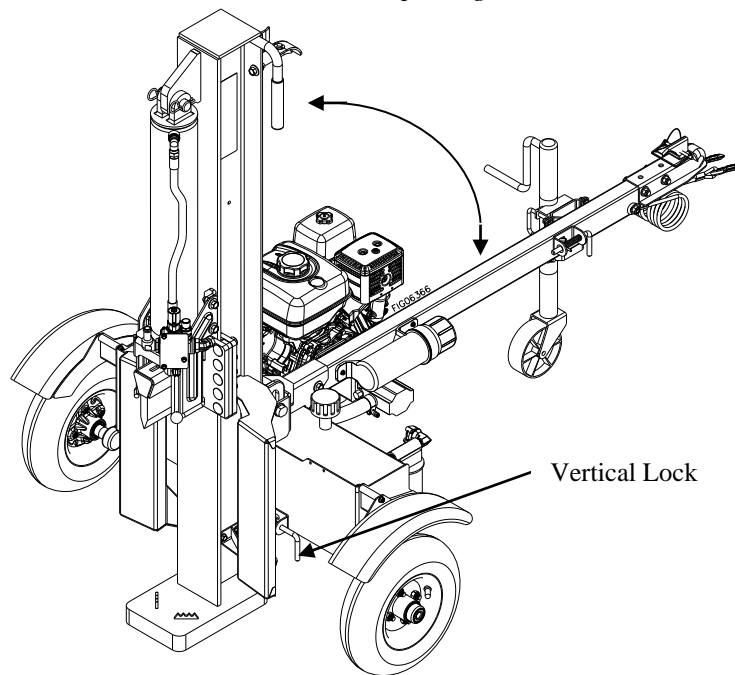

2. Lock in vertical position using vertical locking pin.
3. To return to horizontal position, unlock vertical position, grasp lifting handle and lower beam carefully in a controlled manner until it rests on the tow bar, check that the horizontal latch pin has locked the beam in the horizontal position.

## 4. Start Engine

Start the engine.

See the engine owner's manual for engine starting instructions.

### NOTE:

- a) Make sure the hydraulic oil is above 10°F before starting the engine. Cold hydraulic oil can damage the hydraulic pump.
- b) If outdoor air temperature is below 32°F, allow log splitter to warm up by extending and returning the wedge several times before splitting wood.

### **⚠ WARNING**

**Burns.** To avoid burns, stay clear of hot muffler if you are starting a warm engine.

**Carbon monoxide.** The running engine gives off carbon monoxide, a poisonous gas that can kill you. You CANNOT smell it, see it, or taste it. If you start to feel sick, dizzy, or weak while using the log splitter, shut off the engine and get to fresh air RIGHT AWAY. See a doctor. You may have carbon monoxide poisoning.

**Other exhaust dangers.** Engine exhaust, some of its constituents, and certain vehicle components contain or emit chemicals known to the State of California to cause cancer, birth defects, or other reproductive harm. Avoid inhalation of exhaust.

# Splitting Operation

## 5. Load Log

Load log onto beam with a cut end against the endplate – positioned for a lengthwise cut.

### Notes:

- The log splitter is designed only for cutting lengthwise with the grain, NOT for cutting across the grain.
- This log splitter is designed for cutting logs only up to a maximum of 16" in diameter and 24" long. Larger diameter logs could get stuck on the wedge and longer logs will not fit on the beam.

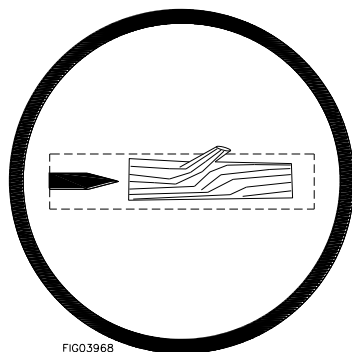
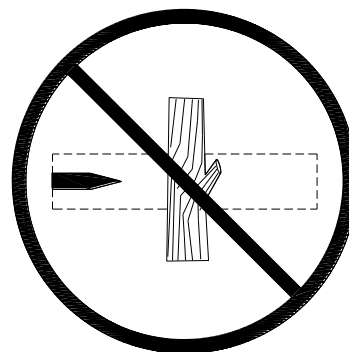
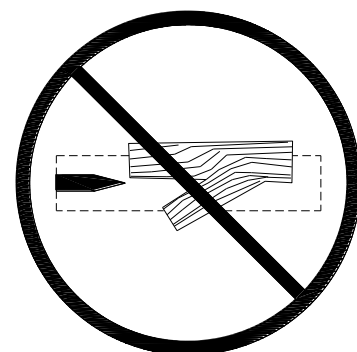

FIG03968

**Correct Log Orientation**



**Incorrect Log Orientation**



**⚠ WARNING:** ALWAYS keep hands and feet away from the endplate, wedge, and partially split logs while loading, operating, and unloading the log splitter.

### Important safety instructions:

- **Hold bark side.** Hold the bark side of logs when loading or positioning, never the ends. Never place your hands or any part of your body between a log and any part of the log splitter.
- NOTE for vertical position loading: Place the log on the endplate and turn it until it leans against the beam and is stable. If the log is too big or oddly shaped, stabilize the log with wooden shims between the log and endplate or ground. **DO NOT** use your leg or knee to stabilize the log. **NEVER** stabilize the log by placing your hand on top of the log.
- **Wedge moving.** NEVER load or unload logs while the wedge is moving.
- **Straddling / reaching across.** Never straddle, reach across, or step over the beam while the engine is running and the log splitter is in the horizontal position. You could trip, actuate the controls, and get seriously injured.
- **Unsplit log pile.** Do not pile logs to be split in a place that will make you reach across the log splitter in order to load them.
- **Square log ends.** Logs that are not cut square can slide out while splitting and become a safety hazard or cause excessive force to log splitter components. Use a chainsaw to cut logs square on each end before attempting to split them.
- **Single log.** Never attempt to split more than one log at a time. Pieces of log can unexpectedly be thrown from the machine causing serious injury.
- **Split along grain.** Do not use the log splitter to split logs across the grain. Doing so will damage the log splitter and could also cause pieces of log to be thrown, injuring the operator or bystanders.
- **Forked logs.** Splitting forked logs can cause damage the log splitter. Trim the forked log with a chain saw prior to splitting the log.
- **Changing splitting position.** Do not change splitting positions (horizontal/vertical) with the engine running. You may contact the muffler and receive serious burns. Be careful to avoid contact with hot muffler even after the engine is turned off.

# Splitting Operation

## 6. Extend Wedge

Move Split Control Lever toward endplate to extend wedge and split log.

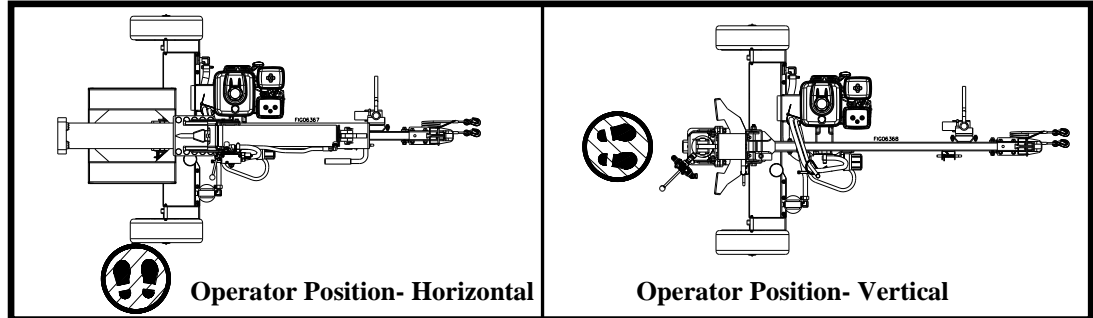
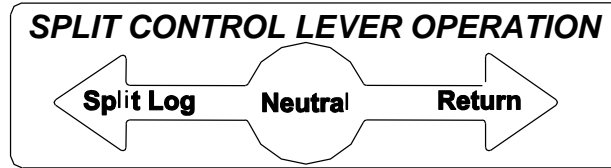

### Important safety instructions:

- **Operator position.** ALWAYS operate the log splitter from the manufacturer's indicated OPERATOR POSITION. (See diagram above.) Other positions are unsafe because they can increase the risk of injury from crushing, cutting, flying objects, or burns.
- **Remove hands.** Remove both hands from log before activating Split Control Lever.
- **Hand activate.** Use only your hand to operate the Split Control Lever. Never use any other body part, or a rope, cable, or other remote device to actuate the control.
- **Second person.** Many accidents occur when there is more than one person involved in loading and operating the log splitter. Only one person should operate the controls. *If a second person is assisting in loading logs, the operator must NEVER actuate the Split Control Lever until the assistant and all bystanders are at least 10 feet away. NEVER allow an assistant to hold the log in place while the operator actuates the Split Control Lever.*

## 7. Stop Wedge

Release Split Control Lever to stop wedge movement when log is split.

**⚠ WARNING:** Cracks in logs can close quickly and pinch fingers. Keep fingers away from any cracks that open in partially split logs.

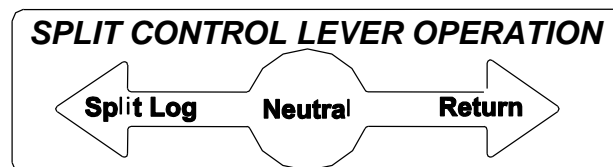

# Splitting Operation

**8. Important  
STUCK LOG  
Procedure**

If a log does not split completely and becomes stuck on the wedge, follow the instructions below to remove the log.  
 A log can become stuck to the wedge if the wedge becomes embedded in the log and the log doesn't split and separate. This can happen if the log is too stringy or tough to split completely.  
 A stuck log will move back with the wedge on the initial attempt to retract the wedge. If this happens, retract the wedge completely to allow the log dislodger to strip the log from the wedge.  
 Keep hands clear of log, wedge, and log dislodger while wedge is retracting.

**⚠️ WARNING: NEVER** attempt to remove a stuck log by:

- Modifying the splitter.
- Adding attachments to the splitter.

Personal injury could result from log or metal pieces flying out at high speed toward the operator or bystanders, or the splitter could become damaged.

**9. Return Wedge**

**Move Split Control Lever away from end plate to return wedge.**

Once the control valve is actuated in the return direction, the wedge is designed to keep returning by itself completely and then stop automatically.

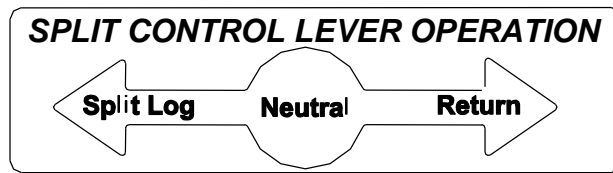

**⚠️ WARNING:** Stay clear while the wedge is returning. It is still powerful enough on the return stroke to cause serious injury. Keep hands away from any moving parts.

**10. Remove Split Wood**

**Remove split wood from area.**

Move each log away from log splitter after it is split. Split logs left near the log splitter are a trip hazard.

**11. After use**

**1. Turn off engine.**

**2. Remove engine debris.**

Debris on a hot engine can be a fire hazard. After the engine is off, clean debris and chaff from engine cylinder head, cylinder head fins, fan housing/recoil starter, and muffler areas.

**⚠️ WARNING:** Avoid contact with hot muffler.

**3. Return to horizontal position.**



If in the vertical position, return log splitter to the horizontal position for greater stability and to prepare for transportation. Avoid contact with hot muffler.

# Storage

## WARNING

Gasoline vapors can ignite and cause a fire. Select a well-ventilated storage away from sources of heat, flame, or sparks.

Follow the instructions below for storing your log splitter between uses.

<b>1. Retract Wedge</b>	<b>Retract the wedge completely to keep the rod protected from corrosion.</b>
<b>2. Cool</b>	<b>Allow the machine to cool 5 minutes before storing.</b>   <b>WARNING:</b> A hot engine can be a fire hazard.
<b>3. Wipe With Oily Rag</b>	<b>Wipe the beam and wedge with an oily rag to prevent corrosion.</b>
<b>4. Engine Manual</b>	<p><b>Refer to the engine manual for proper engine storage instructions.</b></p> <p><b>CAUTION:</b> Gasoline will oxidize and deteriorate in storage. Old gasoline in the engine will cause hard starting and leave gum deposits that can clog the fuel systems. Deterioration problems may occur within a few months, or even less if gasoline was not fresh when you filled the tank.</p> <p><b><u>Short-Term Storage:</u></b></p> <ol style="list-style-type: none"> <li>1. Consider adding a fuel stabilizer to extend fuel storage life.</li> <li>2. Leave the fuel valve lever in the OFF position to reduce the possibility of fuel leakage.</li> </ol> <p><b><u>Long-Term Storage:</u></b> (between infrequent uses and at end of season)</p> <p>Drain the fuel tank and carburetor as instructed in the engine owner's manual.</p> <p><b><u>Important Safety Instructions</u></b></p> <ul style="list-style-type: none"> <li>• Always drain fuel from tank in outdoor, well-ventilated area.</li> <li>• Stay away from sources of heat, flame, or sparks while handling fuel.</li> <li>• Clean up fuel spills/splashes immediately.</li> </ul>
<b>5. Splitter Storage Location</b>	<p><b>Store the log splitter in a location away from corrosive material, sources of heat, open flames, sparks or pilot lights.</b></p> <p> <b>WARNING:</b> Never store log splitter inside where there is a source of heat or an open flame, spark or pilot light – such as water heaters, space heaters, furnaces, clothes dryers, or other gas appliances – <b>EVEN IF</b> the log splitter's gas tank is empty, residual gasoline vapors could ignite.</p> <p><b><u>NOTE:</u></b> Do not store the log splitter near fertilizer or any other corrosive material.</p>
<b>6. Gasoline Storage</b>	<p><b>Store gasoline in a cool, dry place in an UL listed, tightly sealed container.</b></p> <p> <b>WARNING:</b> Gasoline vapors can ignite if they collect inside an enclosure and explosion can result.</p>

# Periodic Maintenance

In addition to the maintenance performed with each use, periodic maintenance should also be performed according to the following schedule.

## ⚠ WARNING

ALWAYS shut off the engine, disconnect the spark plug, and relieve system pressure before cleaning, adjusting, or repairing the splitter. Relieve system pressure by moving Split Control Lever back and forth several times.

### Important:

If a part needs replacement, only use parts that meet the manufacturer's specifications. Replacement parts that do not meet specifications may result in a safety hazard or poor operation of the log splitter.

<b>1. Engine Maintenance</b>	<b>Perform engine maintenance as specified in engine owner's manual.</b>
<b>2. Hydraulic Oil Change</b>	<p><b>Change hydraulic oil annually or every 100 hours.</b></p> <p><b>⚠ WARNING:</b> High fluid pressures and temperatures are developed in hydraulic log splitters. Hydraulic fluid escaping through a pin-hole sized opening can burn or puncture skin, resulting in wounds that could cause blood poisoning, infection, disability, gangrene, amputation, or death. Therefore, the following instructions should be heeded at all times when inspecting or servicing the hydraulic components of the log splitter.</p> <ul style="list-style-type: none"> <li>• NEVER check for leaks with your hand. Leaks can be located by holding a piece of cardboard or wood (at least two feet long) with your hand at one end and passing the other end near the suspected area (wear eye protection). Look for discoloration of the cardboard or wood.</li> <li>• NEVER adjust the pressure of the pump or valve.</li> <li>• If injured by escaping fluid, no matter how small the wound is, see a doctor at once. A typical injection injury may be a small wound that does not look serious. However, severe infection or reaction can result if proper medical treatment is not administered immediately by a doctor who is familiar with injection injuries.</li> </ul> <ol style="list-style-type: none"> <li>1. Fully retract wedge.</li> <li>2. Disconnect the spark plug wire from the spark plug and turn fuel valve off.</li> <li>3. Use 10wt AW32, ASLE H-150, or ISO32 oil. See the "Specifications" section of this manual for hydraulic oil capacity.</li> <li>4. With engine off, relieve hydraulic system pressure by moving Split Control Lever back and forth several times.</li> <li>5. Remove hydraulic oil fill cap. <ul style="list-style-type: none"> <li><b>⚠ WARNING:</b> NEVER remove the hydraulic oil fill cap when the engine is running or hot. Hot oil can escape causing severe burns. Allow the log splitter to cool completely before removing hydraulic oil fill cap.</li> </ul> </li> <li>6. Remove the drain plug from the hydraulic tank to drain the hydraulic oil into a 10 gallon pan.</li> </ol>

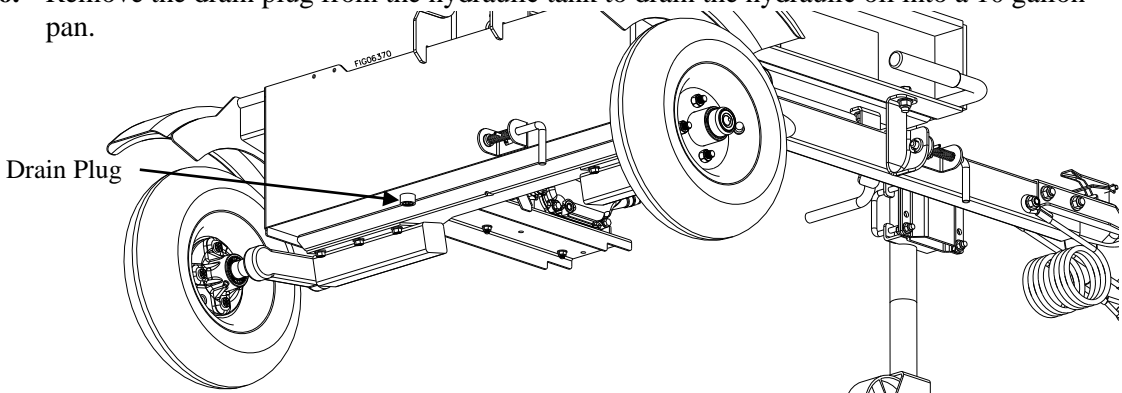

# Periodic Maintenance

## 2. Hydraulic Oil Change (continued)

7. Reinstall drain plug
8. Remove suction strainer and wipe off debris with a dry cloth.
9. Apply thread sealant and reinstall suction strainer

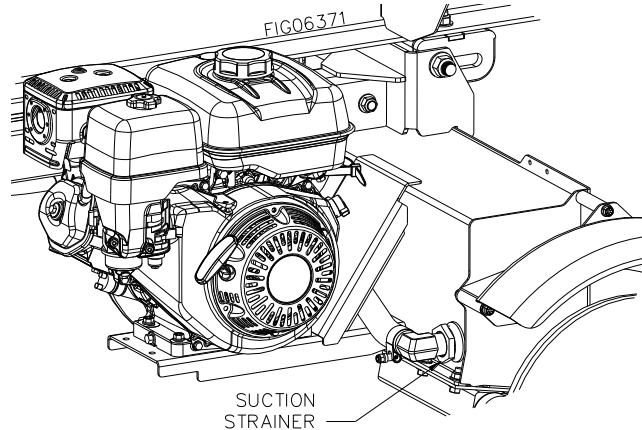

10. Dispose of used oil at an oil-recycling center. Used hydraulic oil is hazardous waste.
11. Fill the hydraulic tank and replace the oil fill cap.
12. Pull on the starter grip recoil at least 20 times so that hydraulic fluid has cycled through the pump.
13. Reconnect the spark plug wire to the spark plug and turn fuel valve on.
14. Start engine. Extend and retract wedge five (5) times to purge air from the system.
15. Check hydraulic oil level with the engine off and wedge retracted. Fill as needed – check that oil level reads between the marks on the dipstick. Note: Do not thread in dipstick when checking oil level.

## 3. Oil Filter Change

**Change return line filter after the first 50 hours of operation, and every 250 hours thereafter.**

Replace return line filter (Refer to the parts breakdown section for part #).

1. Shut down the engine on the Log Splitter.
2. Relieve hydraulic system pressure by moving the splitter control lever back and forth several times.
3. Unthread the canister and discard it along with the accompanying seal. Note: A strap wrench may be required. Not provided.

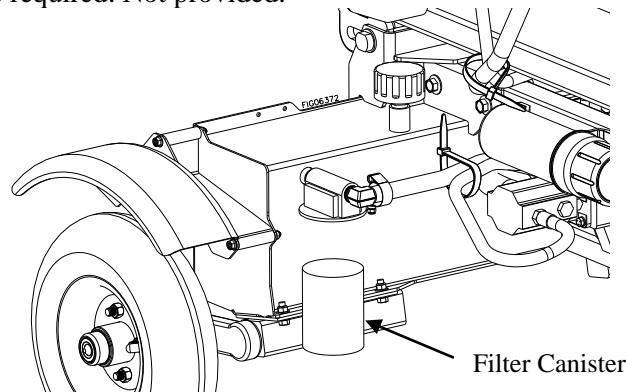

4. Apply a small amount of lubricant to the new canister seal.
5. Install the new canister and hand tighten 3/4 turn after gasket makes contact with head.

## 4. Spark Arrestor Muffler

**If the engine is equipped with a spark arrestor muffler, clean and inspect it regularly (follow engine manufacturer's service instructions). Replace if damaged.**

# Troubleshooting

## ⚠ WARNING

Before troubleshooting or attempting to service, read the following safety instructions to avoid serious injury to the operator or bystanders from moving parts that can crush or cut, burns, fire or explosion, or escaping high pressure hydraulic fluid.

### Important Safety Instructions:

1. **Engine off.** Always make sure the engine is off before cleaning, repairing or adjusting the splitter, except as recommended by the manufacturer.
2. **Hydraulic safety.** High fluid pressures and temperatures are developed in the hydraulic log splitters. Hydraulic fluid escaping through a pin-hole sized opening can burn or puncture skin, resulting in wounds that could cause blood poisoning, infection, disability, gangrene, amputation, or death. Therefore, the following instructions should be heeded at all times when inspecting or servicing the hydraulic components of the log splitter:
  - Stop the engine, disconnect the spark plug, and move all control valve handles back and forth to relieve pressure before changing or adjusting hydraulic components such as hoses, tubing, fittings, or other components.
  - Do not remove the hydraulic oil fill cap when the engine is running. Hot oil can escape causing severe burns. Allow the log splitter to cool completely before removing the hydraulic oil fill cap.
  - Do not adjust the pressure setting to the pump or valve.
  - Do not check for leaks with your hands. Leaks can be located by holding a piece of cardboard or wood (at least 2 feet long) with your hand at one end and passing the other end near the suspected area (wear eye protection). Look for discoloration of the cardboard or wood.
  - If injured by escaping fluid, no matter how small the wound is, see a doctor at once. A typical injection injury may be a small puncture that does not look serious. However, severe infection or reaction can result if proper medical treatment is not administered immediately by a doctor who is familiar with injection injuries.

Problem	
Wedge will not move	Solution: A,D,E,H,J
Slow wedge speed when extending or retracting	Solution: A,B,C,H,I,K
Wood will not split or splits extremely slow	Solution: A,B,C,F,I,K
Engine bogs down during splitting	Solution: G
Engine stalls under low load condition	Solution: D,E
Cause	Solution
<b>A-</b> Insufficient oil to pump	Check oil level in reservoir
<b>B-</b> Air in oil	Check oil level in reservoir, check for leaks in the suction line
<b>C-</b> Excessive pump inlet vacuum	Check pump inlet hose for blockage or kinks
<b>D-</b> Blocked hydraulic lines	Flush and clean the splitter hydraulic system
<b>E-</b> Blocked control valve	Flush and clean the splitter hydraulic system
<b>F-</b> Low control valve setting	Adjust control valve with a pressure gauge
<b>G-</b> High control valve setting	Adjust control valve with a pressure gauge
<b>H-</b> Damaged control valve	Return control valve for authorized repair
<b>I-</b> Internal control valve leak	Return control valve for authorized repair
<b>J-</b> Damaged cylinder piston	Return cylinder for authorized repair
<b>K-</b> Internally damaged cylinder	Return cylinder for authorized repair

**Any Questions, Comments, Problems or Parts Orders**

*Call Iron & Oak Product Support 1-800-817-1005*

# Specifications

	<b>BHVH2418GX</b>	<b>BHVH3018GX BHVH3018GXS</b>	<b>BHVH3018GXT</b>
Splitting Force	24 Ton	30 Ton	30 Ton
Maximum Pressure	3500 PSI	3500 PSI	3500 PSI
Maximum Flow	11 GPM	16 GPM	16 GPM
Hydraulic Tank Capacity	9 Gal	9 Gal	9 Gal
Hydraulic Oil System Capacity (Cylinder, Tank, Hoses & Filter)	10 Gal	10-1/2 Gal	10-1/2 Gal
Hydraulic Fluid Type	*10wt AW32, ASLE H-150, or ISO32		
Cycle Time	13 Seconds	12 Seconds	12 Seconds
Engine	Honda GX160	Honda GX270	Honda GX270
Coupler Size	2"	2"	2"
Maximum Towing Speed	45 MPH	45 MPH	55 MPH pavement, 45 MPH gravel
Operating Position	Vertical/Horizontal	Vertical/Horizontal	Vertical/Horizontal
Maximum Log Length	25"	25"	25"
Maximum Log Diameter	16"	16"	16"
Hydraulic Cylinder Bore	4"	4.5"	4.5"
Hydraulic Cylinder Stroke	24"	24"	24"
Spark Arrestor	No	Yes	Yes
Fuel Valve	Yes	Yes	Yes
Overall Dimensions	93L x 49W x 45H	93L x 49W x 45H	93L x 54W x 45H
Dry Weight	675 lbs.	705 lbs.	730 lbs.
Replacement Filter	BR001113	BR001113	BR001113

\* If the log splitter will be run for long periods of time in outdoor temperatures above 70°F, we recommend changing the hydraulic oil to DEXRON III

The manufacturer reserves the right to make improvements in design and/or changes in specifications at any time without incurring any obligation to install them on units previously sold.

**Any Questions, Comments, Problems or Parts Orders**  
***Call Iron & Oak Product Support 1-800-817-1005***

# Parts Breakdown – Exploded View – Rev F

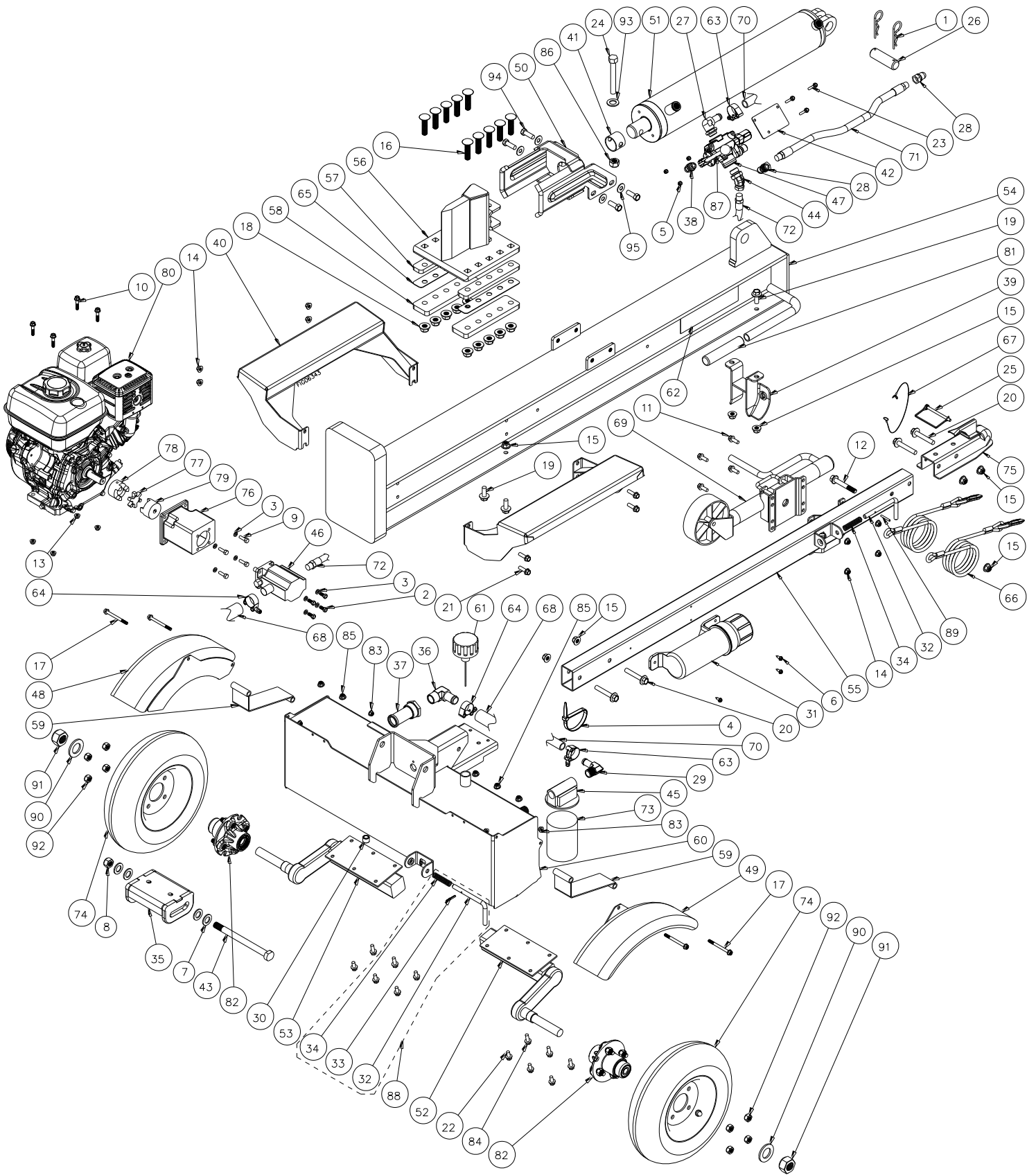

# Parts Breakdown – Exploded View – Rev F

Unit Key: A = BHVH2418GX, B = BHVH3018GX, C = BHVH3018GXT, D = BHVH3018GXS

Ref	Part	Description	#	Unit
1	30313	.177 x 3 Bridge Cotter Pin	2	All
2	82089	5/16-24 x 3/4 HHCS	4	B, C, D
	82087	5/16-18 x 3/4 HHCS	4	A
3	82100	5/16 Split Lock Washer	8	All
4	82157	250# x 14-7/8 Cable Tie	3	All
5	82222	1/4-20 Nylon Lock Nut	3	All
6	82232	1/4 x 3/4 Self Tap Screw	3	All
7	82530	M20 SAE Washer	4	All
8	82567	M18-2.5 Nylon Lock Nut	1	All
9	82601	5/16-24 x 1 HHCS	4	All
10	82622	5/16-18 x 1-1/2 HHFB	4	All
11	82624	3/8-16 x 1 HHFB	4	All
12	82629	1/2-13 x 3-1/2 HHFB	1	All
13	82630	5/16-18 Nylon Lock Flange Nut	4	All
14	82631	3/8-16 Nylon Lock Flange Nut	8	All
15	82632	1/2-13 Nylon Lock Flange Nut	9	All
16	82671	5/8-11 x 2-1/2 Carriage Bolt	10	All
17	82672	5/16-18 x 3-1/2 HHFB	4	C
	82621	5/16-18 x 3/4 HHFB	4	A, B, D
18	82673	5/8-11 Nylon Lock Flange Nut	10	All
19	82675	1/2-13 x 1-1/4 HHFB	8	All
20	82676	1/2-13 x 3 HHFB	4	All
21	82677	3/8-16 x 1-1/4 HHFB	4	All
22	82678	3/8-16 X 3/4 HHFB	7	C
23	82679	1/4-20 X 1-1/2 HHFB	3	All
24	82724	9/16-18 x 3-1/2 HHCS	1	All
25	778498	5/16 x 3-1/2 Catch Pin	1	All
26	778592	1-1/4 Cylinder Clevis Pin	1	All
27	778642	O-Ring x HB Elbow Fitting	1	All
28	778827	O-Ring x FPT Elbow Fitting	2	All
29	778829	MPT x HB Elbow Fitting	1	All
30	787711	1/2" Magnetic Hex Plug	1	All
31	788040	Medium Manual Tube	1	All
32	788243	Latch Rod, Short	2	All
33	788244	Latch Rod Pin	1	All
34	788245	Latch Spring	2	All
35	788343	Pivot Bracket	1	All
36	788504	1" MPT x 1" HB Elbow Fitting	1	B, C, D
	778829	3/4" MPT x 3/4" HB Elbow Fitting	1	A
37	790470	1" FPT x 1-1/2" MPT Strainer	1	B, C, D
	4011	3/4" FPT x 1-1/2" NPT Strainer	1	A
38	790488	Straight Fitting	1	All
39	790548	Beam Rest	1	All
40	790562	Log Table	2	All
41	790564	Adapter Sleeve	1	All
42	790639	Valve Plate	1	All
43	790746	Pivot Bolt	1	All
44	791219	O-Ring x FPT x 45 Elbow Fitting	1	All
45	791244	Small Filter Head	1	All
46	791861	16 GPM Hi/Lo Concentric Pump	1	B, C, D
	791862	11 GPM Hi/Lo Concentric Pump	1	A
47	791869	Brand Valve	1	All
48	798895	Fender Kit (includes both fenders)	1	All
49	798895	Fender Kit (includes both fenders)	1	All
50	794653	Log Dislodger	1	All
51	794826R	4-1/2" x 24" Cylinder w/ Decals	1	B, C, D
	794826K	4-1/2" Cylinder Seal Kit	1	B, C, D
	794827R	4" x 24" Cylinder w/ Decals	1	A
	783885	4" Cylinder Seal Kit	1	A

Ref	Part	Description	#	Unit
52	795800	Right Torsion Stub Axle (includes hub)	1	C
53	795801	Left Torsion Stub Axle (includes hub)	1	C
54	800741	Beam	1	A, B, C
	800741SG	Beam (Green)	1	D
55	797740	Tow Bar	1	All
56	797749	Wedge	1	All
57	797804	Keeper Spacer	2	All
58	797805	Keeper	2	All
59	797808	Fender Extender	2	C
60	797813	Suspension Axle/Tank	1	C
	797728	Axle/Tank	1	A, B
	797728SG	Axle/Tank (Green)	1	D
61	797870	Hydraulic Filter Breather Dipstick Cap	1	All
62	798826	30 Ton Suspension, Iron & Oak Decal	2	C
	797943	30 Ton Iron & Oak Decal	2	B
	797944	24 Ton Iron & Oak Decal	2	A
	798827	30 Ton Green Iron & Oak Decal	2	D
63	797945	Small T-Bolt Hose Clamp	2	All
64	797946	Large T-Bolt Hose Clamp	2	B, C, D
	797945	Small T-Bolt Hose Clamp	2	A
65	798026	Keeper Shim	2	All
66	779542	Safety Cables (includes both)	1	All
67	782689	18" Cable Tether	1	All
68	788207	LP Suction Hose 1" x 25.5"	1	B, C, D
	798451	LP Suction Hose 3/4" x 25.5"	1	A
69	791311	Jack	1	All
70	798452	LP Return Hose 3/4" x 67"	1	All
71	798453	HP Cylinder Ext. Hose	1	All
72	798454	HP Supply Hose 1/2" x 67"	1	All
73	BR001113	Filter Canister	1	All
74	BR008303	Wheel	2	All
75	BR008540	2" Ball Coupler	1	All
76	BR020110	Large Pump Mount Bracket	1	B, C, D
	BR020010	Small Pump Mount Bracket	1	A
77	BR006001B	L090/095 Coupling Insert	1	B, C, D
	BR006002B	L075 Coupling Insert	1	A
78	BR006001C	L095 x 1" Coupling	1	B, C, D
	BR006002C	L075 x 3/4" Coupling	1	A
79	BR006001D	L095 x 1/2" Coupling	1	B, C, D
	BR006002D	L075 x 1/2" Coupling	1	A
80	GX270	Honda Engine, GX270	1	B, C, D
	GX160	Honda Engine, GX160	1	A
81	MX-313786	1" Handle Grip	1	All
82	788301	Wheel Hub	2	All
83	82630	5/16-18 Nylon Lock Flange Nut	4	All
84	82624	3/8-16 x 1 HHFB	5	C
85	82631	3/8-16 Nylon Lock Flange Nut	5	C
86	82725	9/16-18 Nylon Lock Nut	1	All
87	791869HK	Valve Handle Kit	1	All
88	788243K	Latch Rod Kit, Short	1	All
89	799574	3/16 X 11/16 Spring Pin	1	All
90	778844	1" Axle Washer	2	A, B, D
91	777124	1" Axle Nut	2	All
92	82521	1/2" Lug Nut	8	All
93	82205	9/16 SAE Washer	1	All
94	82735	M12-1.75 x 20 HHCS	4	All
95	82038	1/2 SAE Washer	4	All

# Summary of Important Safety information for Operation

## WARNING

Carefully read and make sure you understand the following safety information before using the log splitter. Improper use or maintenance of the log splitter can result in serious injury to the operator or bystanders from moving parts that can crush or cut, flying objects, burns, fire or explosion, escaping high pressure hydraulic fluid, or carbon monoxide poisoning.

### Introduction

- **Read Manual.** Read this operator's manual and the engine Owner's Manual completely before attempting to use the log splitter. Serious injury or death can result if safety instructions are not followed.
- **Instruct operators.** The log splitter owner should instruct all operators in safe log splitter operation.
- **Intended use.** Log splitters should only be used for splitting wood logs, lengthwise with the grain. Do not use for other purposes, as unforeseen hazards may result.

### Prohibition Against Modifications

**Never modify or alter the log splitter in any way. Modifications can create serious safety hazards and will void the warranty.**

- **Attachments.** Never add attachments to the splitter, except for authorized accessories supplied by the manufacturer with instructions for safe installation and use.
- **Engine Speed.** The maximum engine speed is preset at a safe limit. Never attempt to modify the engine speed setting to run at a higher speed.
- **Fuel/Exhaust system.** NEVER modify or add to the exhaust system, fuel tanks, or fuel lines. Fire can result.
- **Remote Control.** NEVER attach a rope, cable, or other remote device to the splitting control.
- **Splitting Wedge.** NEVER attempt to change the height or speed of the splitting wedge.
- **Pressure Setting.** NEVER increase the pressure setting of the pump or control valve.

### Operator Restrictions

- **Untrained Operators.** Do not allow anyone to operate the log splitter who has not read the owner's manual or been instructed on the safe use of the splitter.
- **Minimum Operator Age.** Never allow anyone under age 16 to operate the log splitter. Anyone 16 years of age and older must be trained and supervised by a trained adult.

### Safety in Moving and Towing the Log Splitter

## WARNING

The log splitter is very heavy. It can cause serious injury if it rolls out of control or tips over.

Follow the safety instructions below for safely moving the log splitter.

### General Safety While Moving

- **Horizontal position.** Make sure the log splitter is secured in the horizontal position before moving the log splitter. DO NOT move the log splitter when it is in the vertical position because it will be unstable and could tip.
- **Hills.** Do not move the log splitter up or down hills by hand – use a towing vehicle.
- **Engine off.** Never move the log splitter with its engine running.
- **No riding.** Never allow anyone to sit or ride on the log splitter.
- **No cargo.** Never transport cargo or wood on the log splitter.

### Safety During Towing

- **Read instructions.** Review towing safety instructions in your towing vehicle manual.
- **Securely attached.** Be sure the log splitter is securely attached to the towing vehicle before towing.

# Summary of Important Safety information for Operation

- **Tires.** Be sure the tires are fully inflated and in good repair before towing the log splitter. When adding air to the tires, do not over-inflate – serious injury could occur if tire explodes.
- **Added length.** Be aware of the added length of the splitter.
- **Speed Limit.** Never tow the BHVH2418GX or BHVH3018GX log splitter over 45 mph. Road conditions permitting, the BHVH3018GXT may be towed at up to 55 mph. Faster speeds may result in loss of control.
- **Rough terrain.** Be extra cautious and drive slowly when traveling over rough terrain.
- **Under the influence.** Never tow this splitter while under the influence of alcohol, drugs, or medication.
- **On public roads.** If towing on a public road, make sure to comply with all local, state, and federal towing requirements. It is the sole responsibility of the purchaser to obtain licensing, trailer lights, safety chains or signage, as needed to comply.
- **Unattended.** Turn off the towing vehicle before leaving the splitter unattended.
- **Disconnect before operating.** Do not use the log splitter while it is connected to the towing vehicle.

## Safety – Before Use

### **Read/Instruct**

- **Read manual.** Do not allow anyone to operate the log splitter who has not read the owner's manual or has not been instructed on the safe use of the splitter.
- **Review safety rules.** Before starting this log splitter, review the "Rules for Safe operation." Failure to follow these rules may result in serious injury to the operator or bystanders.
- **Know how to stop.** Be thoroughly familiar with all controls and proper use of the equipment. Know how to stop the splitter and relieve system pressures quickly if needed.

### **Personal Protective Equipment**

- **Eye protection.** Always wear safety glasses or goggles when operating the machine. Pieces of log may fly out and serious eye injury can occur.
- **Boots.** Falling logs can crush feet. Always wear safety shoes or heavy boots when operating or helping to load logs.
- **Loose/dangling.** Loose or dangling apparel can become entangled in moving parts. Never wear jewelry or loose-fitting clothing.
- **Gloves.** Wear snug fitting gloves without drawstrings or loose cuffs.
- **Hearing Protection.** The use of earplugs or other hearing protection device is recommended.

### **Safety During Inspection/Maintenance**

Always inspect your log splitter before each use, and repair as needed, to keep it in safe working condition:

- **Engine off.** Always make sure the engine is off before cleaning, repairing or adjusting the splitter, except as recommended by the manufacturer.
- **Engine debris.** Debris on a hot engine can be a fire hazard. With the engine off, clean debris and chaff from engine cylinder head, cylinder head fins, fan housing/recoil starter, and muffler areas. Avoid contact with hot muffler.
- **Other debris.** Debris on moving parts can cause excess wear. With the splitter engine off, clear debris from moving parts.
- **Fuel tank / lines.** Before each use, check fuel tank and fuel lines for leaks. Any fuel leak is a fire hazard. Fix any fuel leaks before starting engine.
- **Mechanical parts.** Check to be sure that all nuts and bolts are tight to make sure the log splitter is in safe working condition.
- **Hydraulic system.** Check the hydraulic system (hoses, tubing, clamps/fittings, pump, and cylinder) carefully before each use. Do not operate the log splitter with frayed, kinked, cracked or damaged hydraulic hoses, fittings, or tubing, or if oily residue is observed on any of the components. High fluid pressures and temperatures are developed in the log splitter. Hydraulic fluid escaping through a pin-hole sized opening can burn or puncture skin, resulting in wounds that could cause blood poisoning, infection, disability, gangrene, amputation, or death. Therefore, the following instructions should be heeded at all times when inspecting or servicing the hydraulic components of the log splitter:
  - Do not remove the hydraulic oil cap when the engine is running. Hot oil can escape causing severe burns. Allow log splitter to cool completely before removing hydraulic oil cap.
  - Do not adjust the pressure setting of the pump or valve.

# Summary of Important Safety information for Operation

- o Do not check for leaks with your hand. Leaks can be located by holding a piece of cardboard or wood (at least two feet long) with your hand at one end and passing the other end near the suspected area (wear eye protection). Look for discoloration of the cardboard or wood.
- o Stop the engine, disconnect the spark plug, and move all control valve handles back and forth to relieve pressure before changing or adjusting hydraulic system components such as hoses, tubing, fittings or other components.
- o If injured by escaping fluid, no matter how small the wound is, see a doctor at once. A typical injection injury may be a small puncture wound that does not look serious. However, severe infection or reaction can result if proper medical treatment is not administered immediately by a doctor who is familiar with injection injuries.
- **Spark arrestor muffler.** If the engine is equipped with a spark arrestor muffler, clean and inspect it regularly (follow manufacturer's service instructions). Replace if damaged.
- **Tires.** Be sure tires are fully inflated and in good repair before towing the splitter. When adding air to tires, do not over-inflate -- serious injury could occur if tire explodes.
- **Guards / shields.** Make sure all guards and shields are replaced after servicing the log splitter.
- **Replacement parts.** If a part needs replacement, only use parts that meet the manufacturer's specifications. Replacement parts that do not meet specifications may result in a safety hazard or poor operation of the log splitter.

## Safety During Fueling

- **Gasoline is highly flammable and explosive.** You can be burned or seriously injured when handling fuel. Use extreme care when handling gasoline:
- **Fuel outdoors.** Fill fuel tank outdoors – never indoors. Gasoline vapors can ignite if they collect inside an enclosure. Explosion can result.
- **Use approved container.** Never pump fuel directly into engine at gas station. Static charge can build and ignite fuel. Use an UL approved fuel container to transfer gas to the engine.
- **Running / hot engine.** A running engine is hot enough to ignite fuel. Never add fuel or remove gas cap if engine is running or still hot. Stop the engine and allow to cool at least two minutes before adding fuel.
- **Heat / flames / sparks.** Stay away from sources of heat, flame, or sparks while adding fuel.
- **Don't overfill.** DO NOT overfill the gas tank. Allow at least 1/2" of empty space below the fill neck to allow for fuel expansion.
- **Replace cap.** Replace gas cap securely before starting engine.
- **Spills.** Clean up fuel spills immediately. Move log splitter away from spilled fuel on the ground. Wipe fuel off engine and wait 5 minutes for excess fuel to evaporate before starting engine. Gas soaked rags should be disposed of properly.
- **On skin / clothes.** If gasoline is spilled on your skin or clothes, change clothes and wash skin immediately.
- **Gasoline storage.** Store gasoline in a cool, dry place in an UL approved, tightly sealed container.

## Safety in Work Site Selection

- **Spark arrestor.** If your splitter will be used near any unimproved forest, brush, or grassy covered land, then engine should be equipped with a spark arrestor. See the "Specifications" section of this manual to determine if your splitter already has a spark arrestor. Make sure you comply with applicable local, state and federal codes.
- **Hot exhaust.** Hot exhaust fumes from engine can cause fire. Position muffler at least 7' from combustible objects during operation.
- **Fire extinguisher.** Keep a class ABC fire extinguisher available as a precautionary measure when operating the log splitter in dry areas.
- **Level, dry surface.** To prevent accidental falls and equipment tip over, make sure the splitter is situated on a dry, level surface with good footing. Stay clear of areas with mud, ice, tall grass, weeds, brush, or snow.
- **Block wheels.** Always block the wheels to prevent unintended movement of the log splitter.
- **Carbon monoxide.** The running engine gives off carbon monoxide, a poisonous gas that can kill you. You CANNOT smell it, see it, or taste it. ONLY run log splitter OUTDOORS and away from air intakes. NEVER run log splitter inside homes, garages, sheds, or other semi-enclosed spaces. These spaces can trap poisonous gases, EVEN if you run a fan or open windows. If you start to feel sick, dizzy, or weak while using the log splitter, shut off the engine and get to fresh air RIGHT AWAY. See a doctor. You may have carbon monoxide poisoning.

# Summary of Important Safety information for Operation

## Safety – During Use General Safety During Use

**⚠ WARNING:** Before starting this log splitter, review the following rules for safe operation. Failure to follow these rules may result in serious injury to the operator or bystanders.

- **Safety equipment / controls.** Always operate the log splitter with all safety equipment in place and in good working order, and all controls properly adjusted for safe operation.
- **Operating speed.** Always operate the log splitter at the manufacturer's recommended speed. The maximum speed of the engine, pump and wedge are preset within safe limits.
- **Know how to stop.** Be thoroughly familiar with all controls and with the proper use of the equipment. Know how to stop the log splitter and relieve system pressures quickly if needed.
- **Daylight only.** Only use the log splitter in daylight so you can see what you are doing.
- **Smoking / sparks.** Never smoke while operating the log splitter, and never operate near sources of sparks or flames.
- **Hot muffler.** If you are starting a warm engine, stay clear of muffler. It may still be hot enough to burn you.
- **Unattended.** Never leave the machine unattended while the engine is running.
- **Under the influence.** Never operate, or let anyone else operate, the log splitter while under the influence of alcohol, drugs, or medication.
- **Adjusting / repairing.** Always make sure the engine is off before cleaning, repairing or adjusting the splitter, except as recommended by the manufacturer. In addition, disconnect the spark plug and move all control handles back and forth to relieve system pressure *before changing or adjusting hydraulic system components* such as hoses, tubing, fittings or other components.
- **Carbon monoxide.** The running engine gives off carbon monoxide, a poisonous gas that can kill you. You CANNOT smell it, see it, or taste it. If you start to feel sick, dizzy, or weak while using the log splitter, shut off the engine and get to fresh air RIGHT AWAY. See a doctor. You may have carbon monoxide poisoning.
- **Other exhaust dangers.** Engine exhaust, some of its constituents, and certain vehicle components contain or emit chemicals known to the State of California to cause cancer, birth defects, or other reproductive harm. Avoid inhalation of exhaust.

### Safety in Loading, Operating, and Unloading

- **Square log ends.** Logs that are not cut square can slide out while splitting and become a safety hazard or cause excessive force to log splitter components. Use a chainsaw to cut logs square on each end before attempting to split them.
- **Single log.** Never attempt to split more than one log at a time. Pieces of log can unexpectedly be thrown from the machine causing serious injury.
- **Split along grain.** Do not use the log splitter to split logs across the grain. Doing so will damage the log splitter and could also cause pieces of log to be thrown, injuring the operator or bystanders.
- **Forked logs.** Splitting forked logs can cause damage the log splitter. Trim the forked log with a chain saw prior to splitting the log.
- **Keep hands clear.** ALWAYS keep hands and feet away from the endplate, wedge, and partially split logs while loading, operating and unloading the log splitter.
- **Operator position.** ALWAYS operate the log splitter from the manufacturer's indicated OPERATOR POSITION. Other positions are unsafe because they can increase the risk of injury from crushing, cutting, flying objects, or burns.
- **Straddling / reaching across.** Never straddle, reach across, or step over the beam while the engine is running and the log splitter is in the horizontal position. You could trip, actuate the controls, and get seriously injured.
- **Second person.** Many accidents occur when there is more than one person involved in loading and operating the log splitter. Only one person should operate the controls. *If a second person is assisting in loading logs, the operator must NEVER actuate the Split Control Lever until the assistant and all bystanders are at least 10 feet away. NEVER allow an assistant to hold the log in place while the operator actuates the Split Control Lever.*

# Summary of Important Safety information for Operation

## Loading/Unloading

- **Unsplit log pile.** Do not pile logs to be split in a place that will make you reach across the log splitter in order to load them.
- **Hold bark side.** Hold the bark side of logs when loading or positioning, never the ends. Never place your hands or any part of your body between a log and any part of the log splitter.
- **NOTE for vertical position loading:** Place the log on the endplate and turn it until it leans against the beam and is stable. If the log is too big or oddly shaped, stabilize the log with wooden shims between the log and endplate or ground. DO NOT use your leg or knee to stabilize the log. NEVER stabilize the log by placing your hand on top of the log.
- **Wedge moving.** NEVER load or unload logs while the wedge is moving.
- **Cracks.** Cracks in logs can close quickly and pinch fingers. Keep fingers away from any cracks that open in partially split logs.
- **Split log pile.** Move each log away from log splitter after it is split. Split logs left near the log splitter are a trip hazard.
- **Remove hands.** Remove both hands from log before activating Split Control Lever.
- **Hand activate.** Use only your hand to operate the Split Control Lever. Never use any other body part, or a rope, cable, or other remote device to actuate the control.
- **Returning wedge.** Once the control valve is actuated in the return direction, the wedge is designed to keep returning by itself completely and then stop automatically. Stay clear while the wedge is returning. It is still powerful enough on the return stroke to cause serious injury.
- **Log stuck on wedge.** If a log does not split completely and becomes stuck on the wedge, follow the instructions below to remove the log. A log can become stuck to the wedge if the wedge becomes embedded in the log and the log doesn't split and separate. This can happen if the log is too stringy or tough to split completely. A stuck log will move back with the wedge on the initial attempt to retract the wedge. If this happens, retract the wedge completely to allow the log dislodger to strip the log from the wedge. Keep hands clear of log, wedge, and log dislodger while wedge is retracting.

**⚠ WARNING: NEVER** attempt to remove a stuck log by:

- Modifying the splitter.
- Adding attachments to the splitter.

Personal injury could result from log or metal pieces flying out at high speed toward the operator or bystanders, or the splitter could become damaged.

- **Changing splitting position.** Do not change splitting positions (horizontal/vertical) with the engine running. You may contact the muffler and receive serious burns. Be careful to avoid contact with hot muffler even after the engine is turned off.
- **Refueling.** Never refuel the engine until it has cooled at least two minutes.

## Safety – After use

- **Return to horizontal.** If in the vertical position, turn off engine and return log splitter to the horizontal position for greater stability and to prepare for transportation. Avoid contact with hot muffler.
- **Remove engine debris.** Debris on a hot engine can be a fire hazard. With the engine off, clean debris and chaff from engine cylinder head, cylinder head fins, fan housing/recoil starter, and muffler areas. Avoid contact with hot muffler.
- **Let engine cool before storing.** Let engine cool for at least five minutes before storing. A hot engine can be a fire hazard.
- **Storage location.** Store the log splitter in a location away from sources of heat, open flames, sparks or pilot lights – such as water heaters, space heaters, furnaces, clothes dryers, or other gas appliances. Even if the log splitter's gas tank is empty, residual gasoline vapors could ignite.
- **Gasoline storage.** Store extra gasoline in a cool, dry place in an UL approved, tightly sealed container. Gasoline vapors can ignite if they collect inside an enclosure.
- **Periodic maintenance.** Perform periodic maintenance as directed in this manual to keep the log splitter in safe working condition.

# Assembly Instructions

Dismantle shipping crate and remove parts from any boxes. Cut all banding and remove packaging materials from all components. Using this manual, identify and sort components as necessary.

## CAUTION

The bands holding the log splitter and other items in place are under tension and can fly outward when cut. Wear the appropriate personal protective equipment to reduce the risk of injury. Never stand in front of or over the band when cutting. Always stand to the side in a safe area.

### Closely inspect all log splitter components.

If you have missing or damaged components, please contact Product Support at 1-800-817-1005.

Find a work space that is large enough to maneuver log splitter once completely assembled. Assemble log splitter on solid and level ground.

## CAUTION

**Heavy lifting required.** Some of the components in these assembly instructions are heavy and cannot be lifted by one person safely. Plan on assembling this product when another person can be available to help.

**Tools needed:** Two adjustable wrenches, 13/16" socket, ratchet, torque wrench, 3/4" socket, 3/4" wrench, pliers, side cutters, 9/16" socket, 9/16" wrench, 1/2" socket, and 1/2" wrench, 10mm deep well socket.

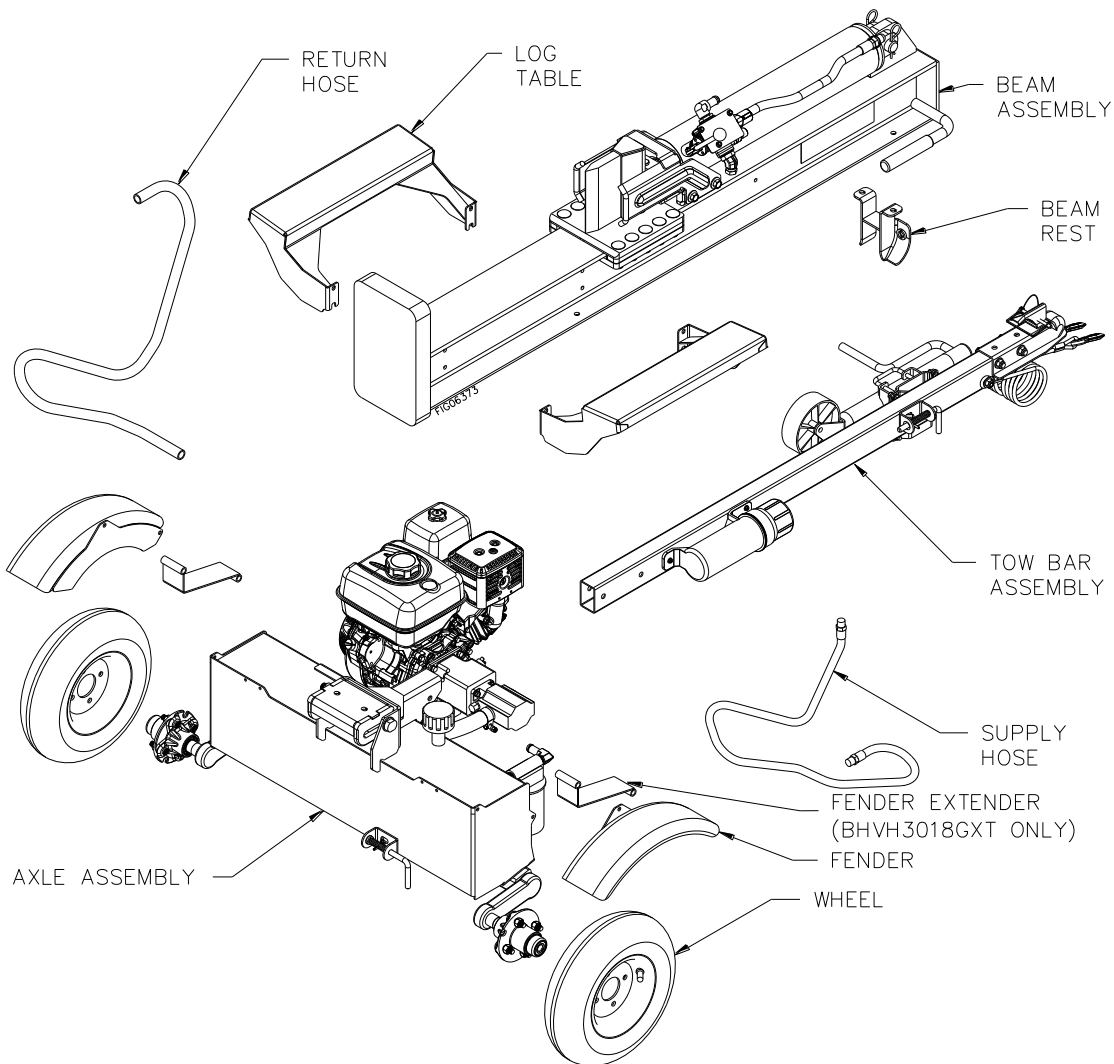

# Assembly Instructions

## Parts Bag Contents

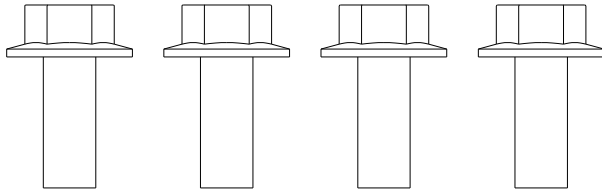

**Part # 82675**  
**1/2-13 x 1-1/4 HHFB**  
**Qty: 4**

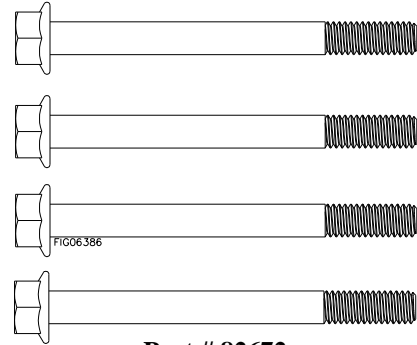

**Part # 82672**  
**5/16-18 x 3-1/2 HHFB**  
**(BHVH3018GXT only)**  
**Qty: 4**

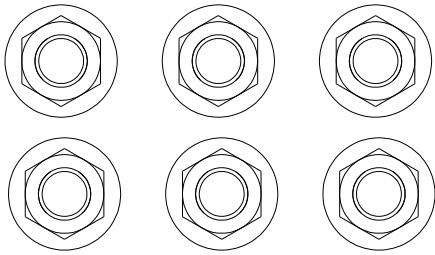

**Part # 82632**  
**1/2-13 Nylon Lock Flange Nut**  
**Qty: 6**

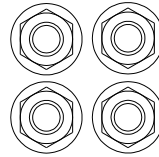

**Part # 82630**  
**5/16-18 Nylon Lock Flange Nut**  
**Qty: 4**

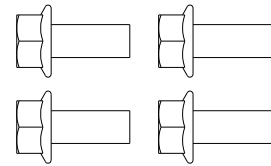

**Part # 82621**  
**5/16-18 x 3/4 HHFB**  
**(all units except BHVH3018GXT)**  
**Qty: 4**

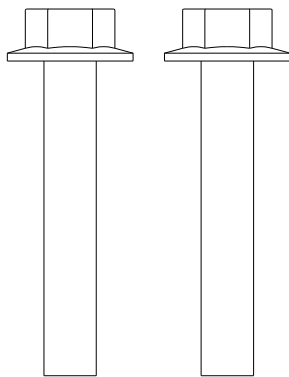

**Part # 82676**  
**1/2-13 x 3 HHFB**  
**Qty: 2**

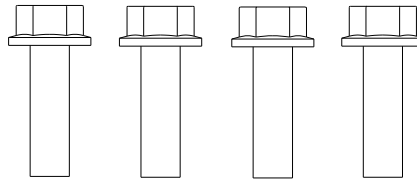

**Part # 82677**  
**3/8-16 x 1-1/4 HHFB**  
**Qty: 4**

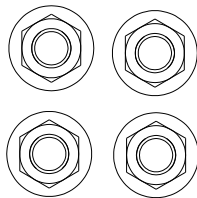

**Part # 82631**  
**3/8-16 Nylon Lock Flange Nut**  
**Qty: 4**

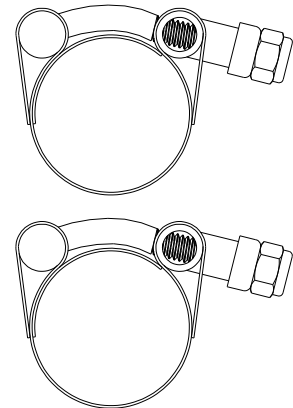

**Part # 797945**  
**1-1/8 to 1-1/4 T-Bolt Hose Clamp**  
**Qty: 2**

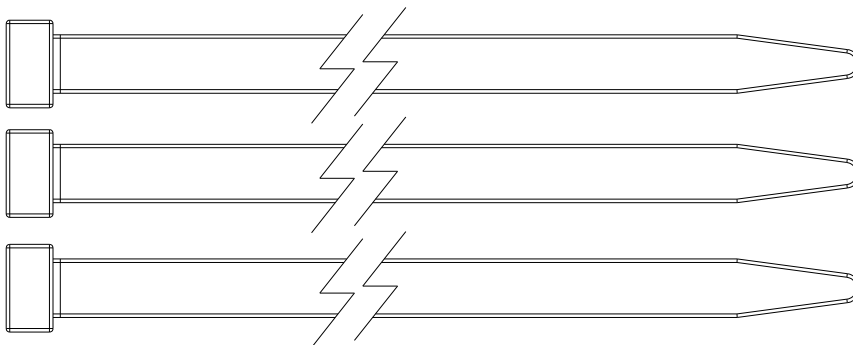

**Part # 82157**  
**Zip Tie**  
**Qty: 3**

# Assembly Instructions

## Step 1 – Wheels to Hubs

- Remove lug nuts from studs
- Slide tire onto hub with valve stem facing out.
- Thread nuts onto studs until hand tight. Tighten the lug nuts in stages. Follow the sequence listed:

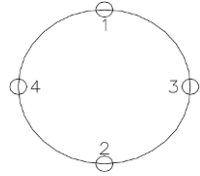

4 Bolt Hub

- Torque nuts to: 1<sup>st</sup> Stage: 20-25 ft.-lbs., 2<sup>nd</sup> Stage: 35-40 ft.-lbs., 3<sup>rd</sup> Stage: \*60-75 ft.-lbs. \* Verify final torque based on wheel type and wheel manufacture recommendations.
- Repeat steps for other side.

## Tools Needed

- 13/16" Socket
- Ratchet
- Torque Wrench

**NOTE:** As a precaution, block wheels to prevent movement of log splitter while torquing lug nuts.

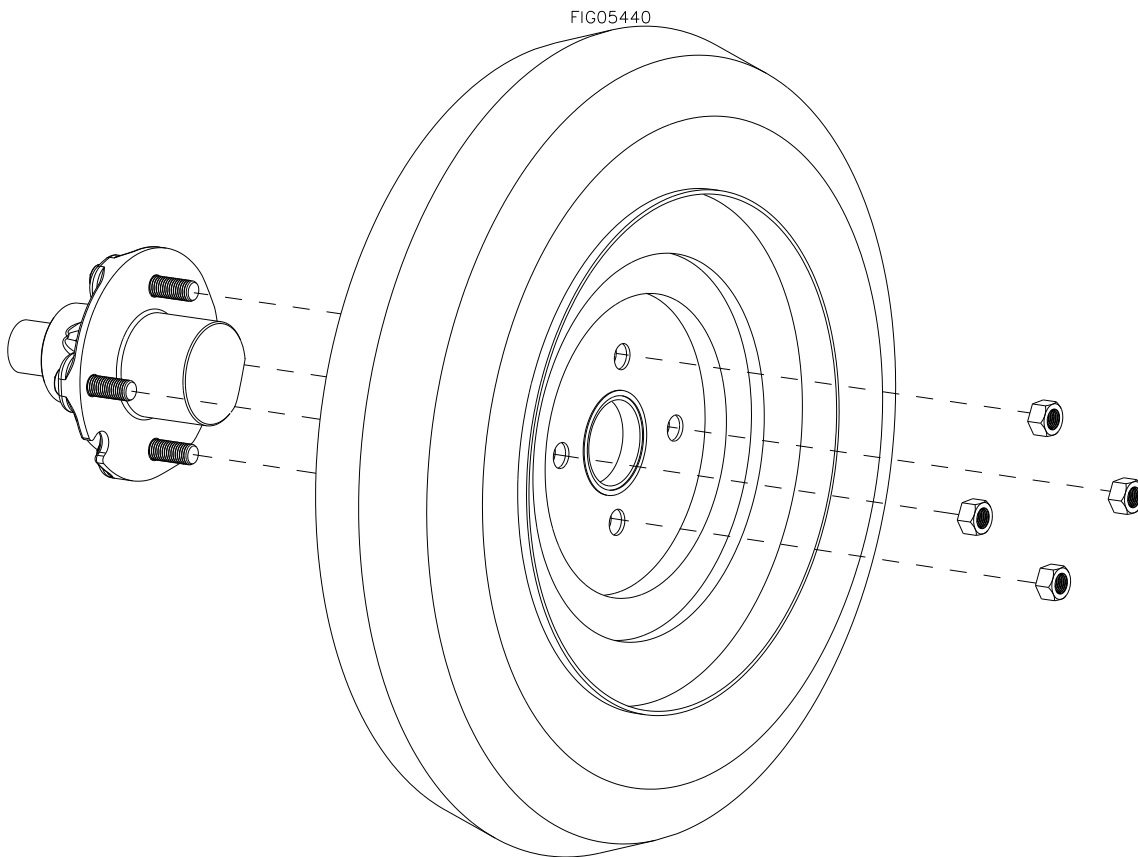

# Assembly Instructions

## Step 2 – Tow Bar Assembly to Axle Assembly

- Slide tow bar assembly into the beam mount on top of the axle assembly. (If you purchased a light kit for this unit, follow the instructions with the kit before installing the tow bar.)
- Lock the jack in the down position on a flat surface and adjust so the tow bar sits level.
- Align the holes and install (2) bolts and (2) nuts.
- Torque to 50 ft.-lb.

## Tools Needed

- Ratchet
- Torque Wrench
- 3/4" Socket
- 3/4" Wrench

### Fasteners Needed from Parts Bag:

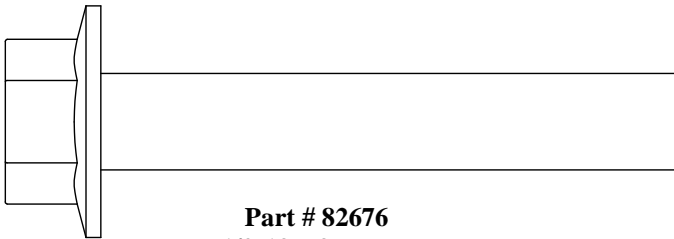

**Part # 82676**  
**1/2-13 x 3 HHFB**  
**Qty: 2**

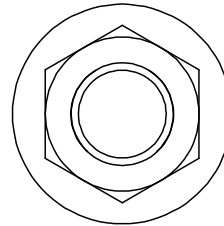

**Part # 82632**  
**1/2-13 Nylon Lock Flange Nut**  
**Qty: 2**

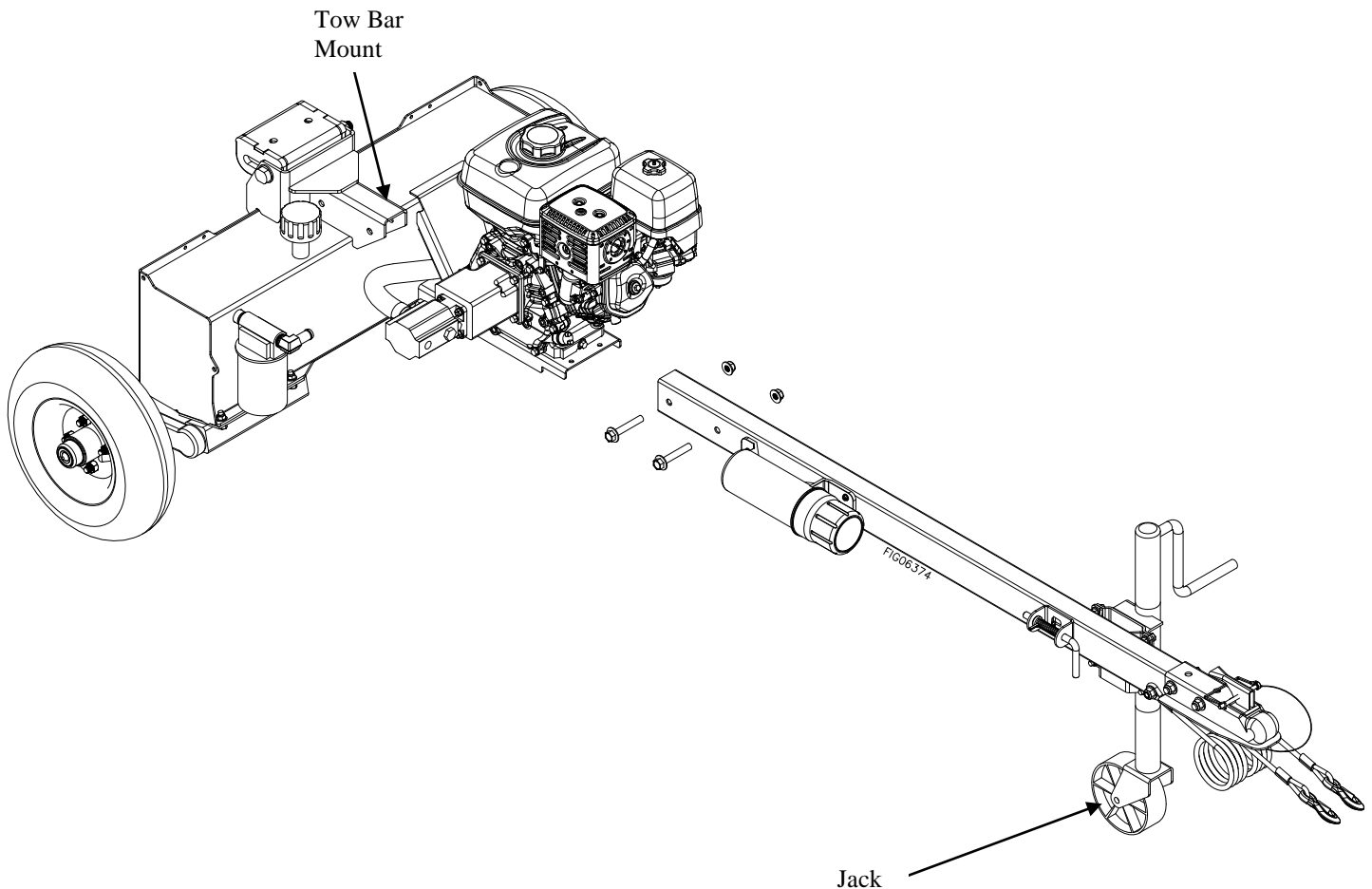

# Assembly Instructions

## Step 3 – Stand beam upright

- CAUTION: Beam assembly is top heavy.
- Carefully stand beam assembly in vertical position on solid, level ground. **Assistance from a second person is required.**

## Tools Needed

- None

### WARNING

Make sure beam assembly is standing on flat, level area. Have another person steady the beam to prevent it from tipping over. The beam assembly weighs approximately 350 pounds and will cause bodily injury if it falls on someone.

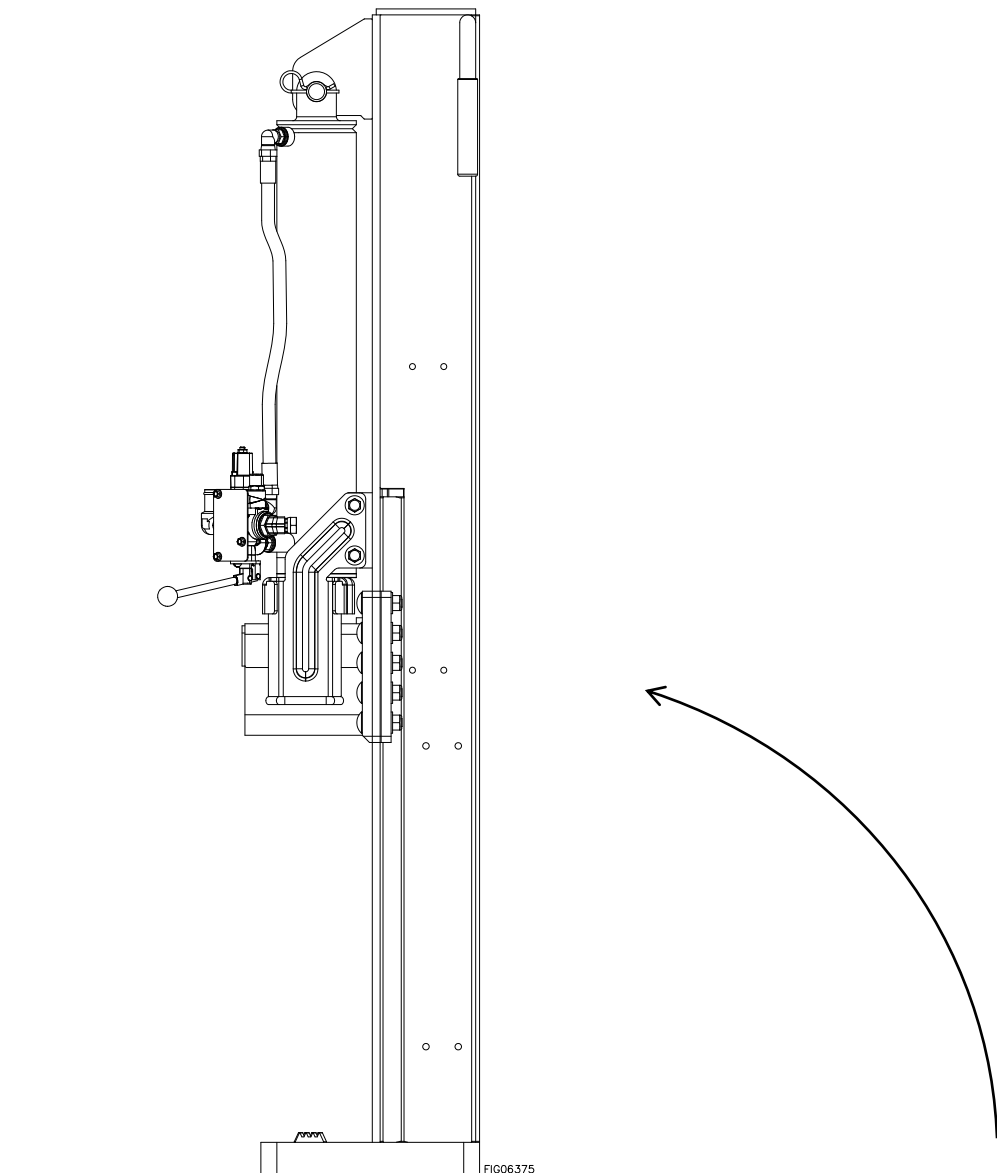

# Assembly Instructions

## Step 4 –Beam Assembly to Axle Assembly

- Carefully align the axle assembly with the beam assembly. Have a person hold the beam in place while maneuvering any assembly.
- Align holes in pivot bracket with holes in bottom of beam.
- Insert (2) bolts as shown.
- Add (2) nuts. Hand tighten nuts. Do not torque at this time.

## Tools Needed

- None

### Fasteners Needed from Parts Bag:

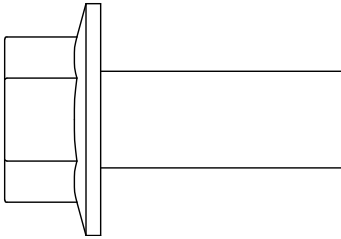

**Part # 82675**  
**1/2-13 x 1-1/4 HHFB**  
**Qty: 2**

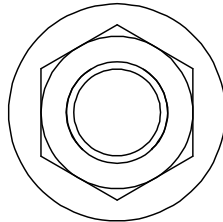

**Part # 82632**  
**1/2-13 Nylon Lock Flange Nut**  
**Qty: 2**

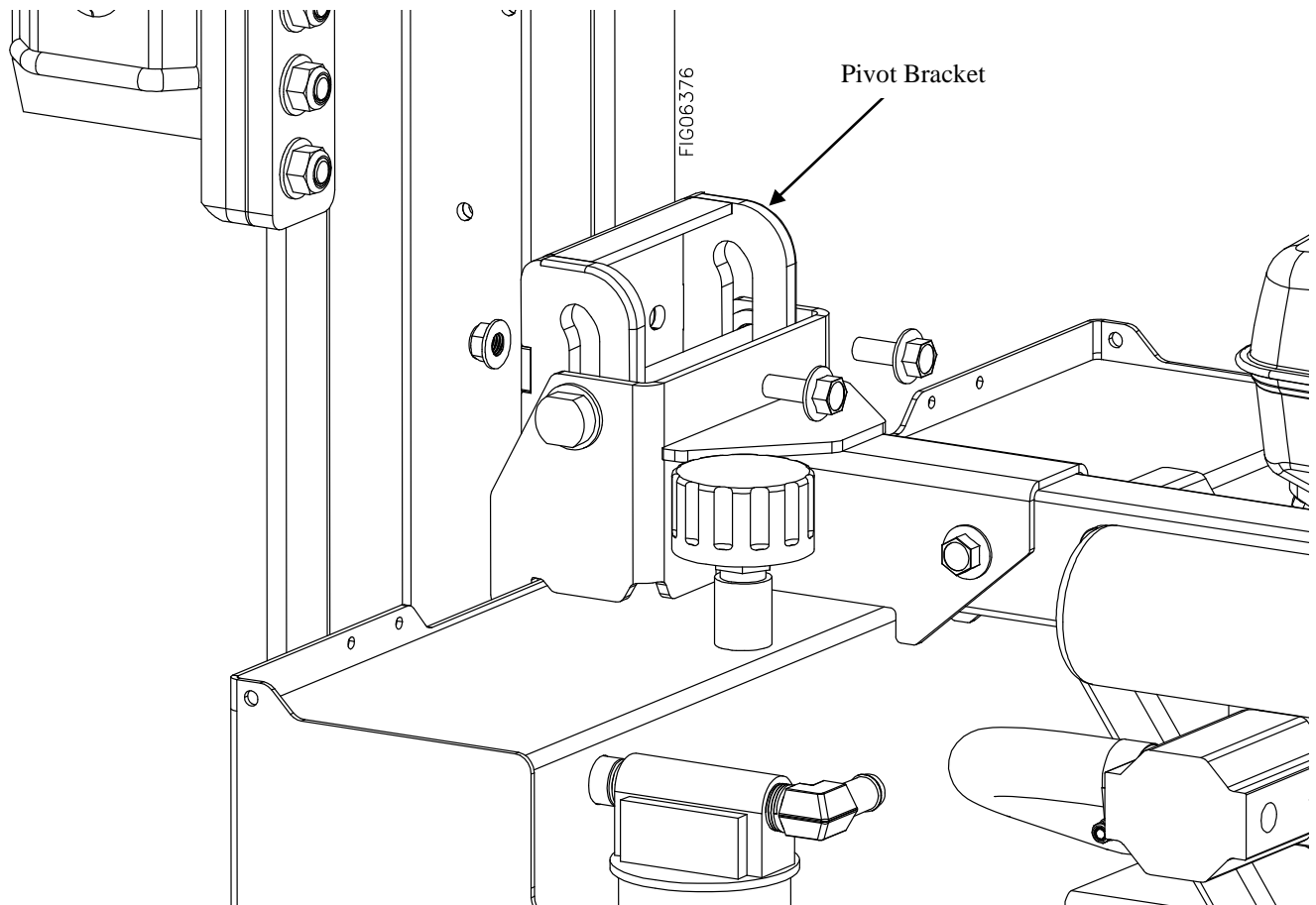

# Assembly Instructions

## Step 5 – Beam rest

- Align beam rest with beam rest mounting bracket with the latching face on the valve side of the splitter. Attach to the beam using (2) bolts and (2) nuts. Hand tighten nuts. Do not torque at this time.

## Tools Needed

- None

### Fasteners Needed from Parts Bag:

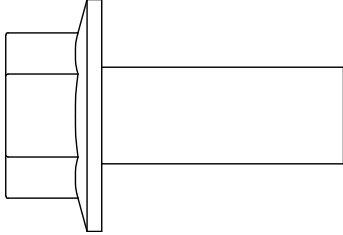

**Part # 82675**  
**1/2-13 x 1-1/4 HHFB**  
**Qty: 2**

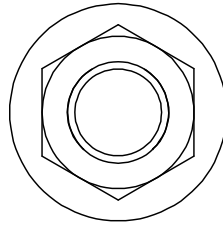

**Part # 82632**  
**1/2-13 Nylon Lock Flange Nut**  
**Qty: 2**

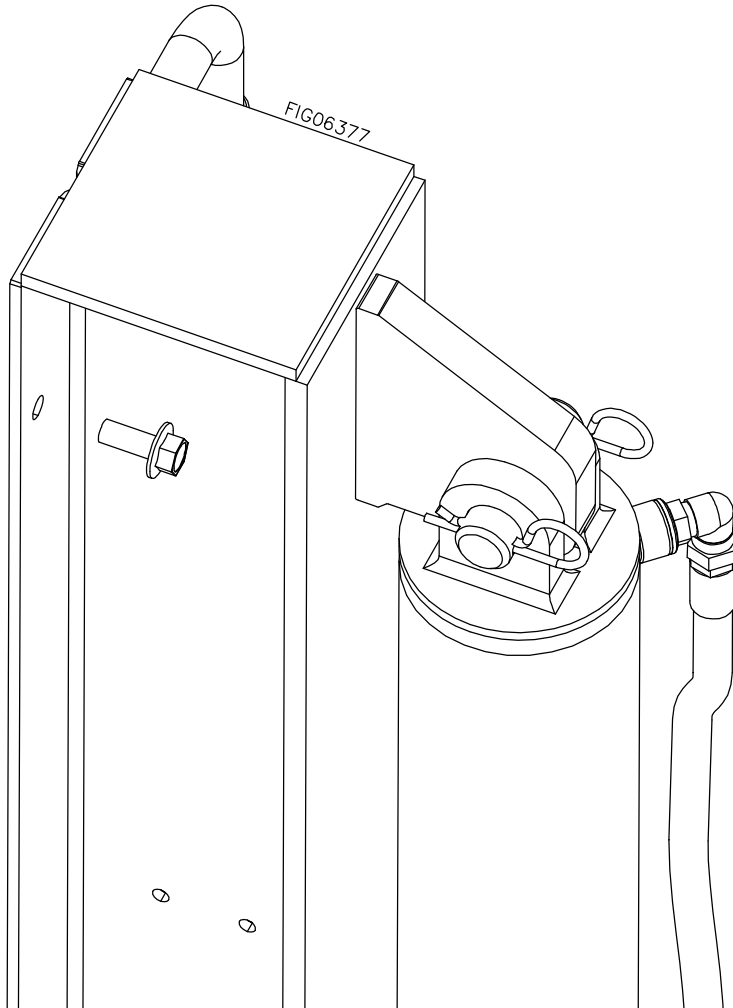
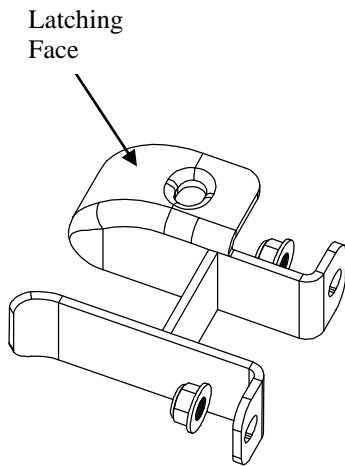

# Assembly Instructions

## Step 6 – Block and Rotate

- Block the wheels and carefully rotate the beam assembly to the horizontal position.
- Adjust beam rest to ensure horizontal latch indeed latches the beam in the horizontal position.
- Torque fasteners installed in Step 4 and Step 5 to 83 ft.-lbs.

## Tools Needed

- Torque Wrench
- Ratchet
- 3/4" Socket
- 3/4" Wrench

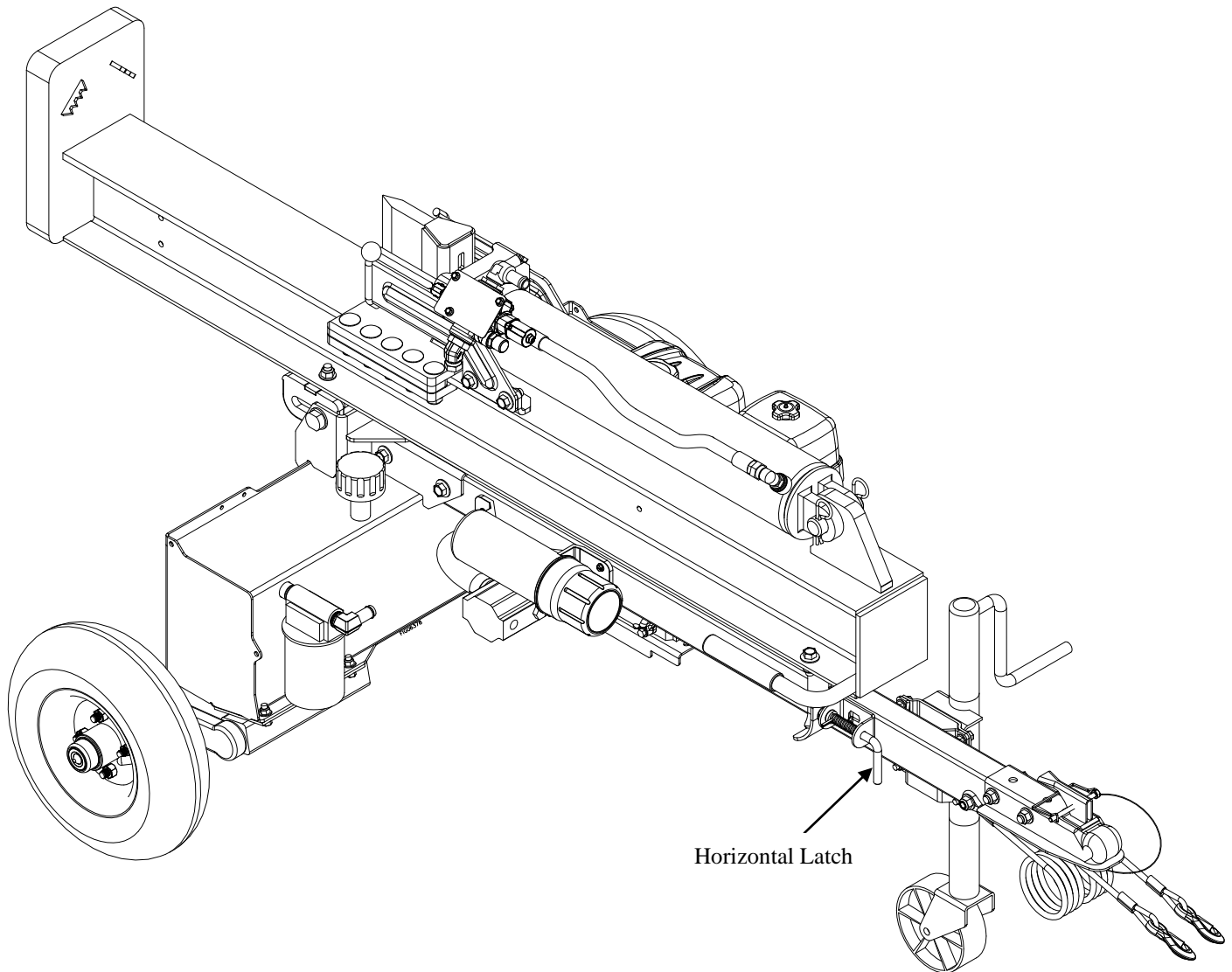

# Assembly Instructions

## Step 7 – High Pressure Supply Hose

- Rotate splitter to vertical position and latch the vertical latch.
- Remove plastic plug from pump outlet with pliers (plastic plug is the outer most fitting).
- Apply thread sealant to hose threads on only one end of the hose. Screw hand-tight High Pressure Supply Hose end with thread sealant applied into the pump outlet.
- Wrench-tighten the fitting to 1.5-3.0 Turns Past Finger Tight position. Properly assembled fittings total thread engagement should be 3.5-6 turns.
- Route hose around the tow bar as shown.
- Screw finger-tight remaining end of the High Pressure Supply Hose to the Valve Inlet Fitting on the control valve inlet.
- Wrench-tighten the fitting.

## Tools Needed

- (2) Adjustable Wrenches
- Pliers

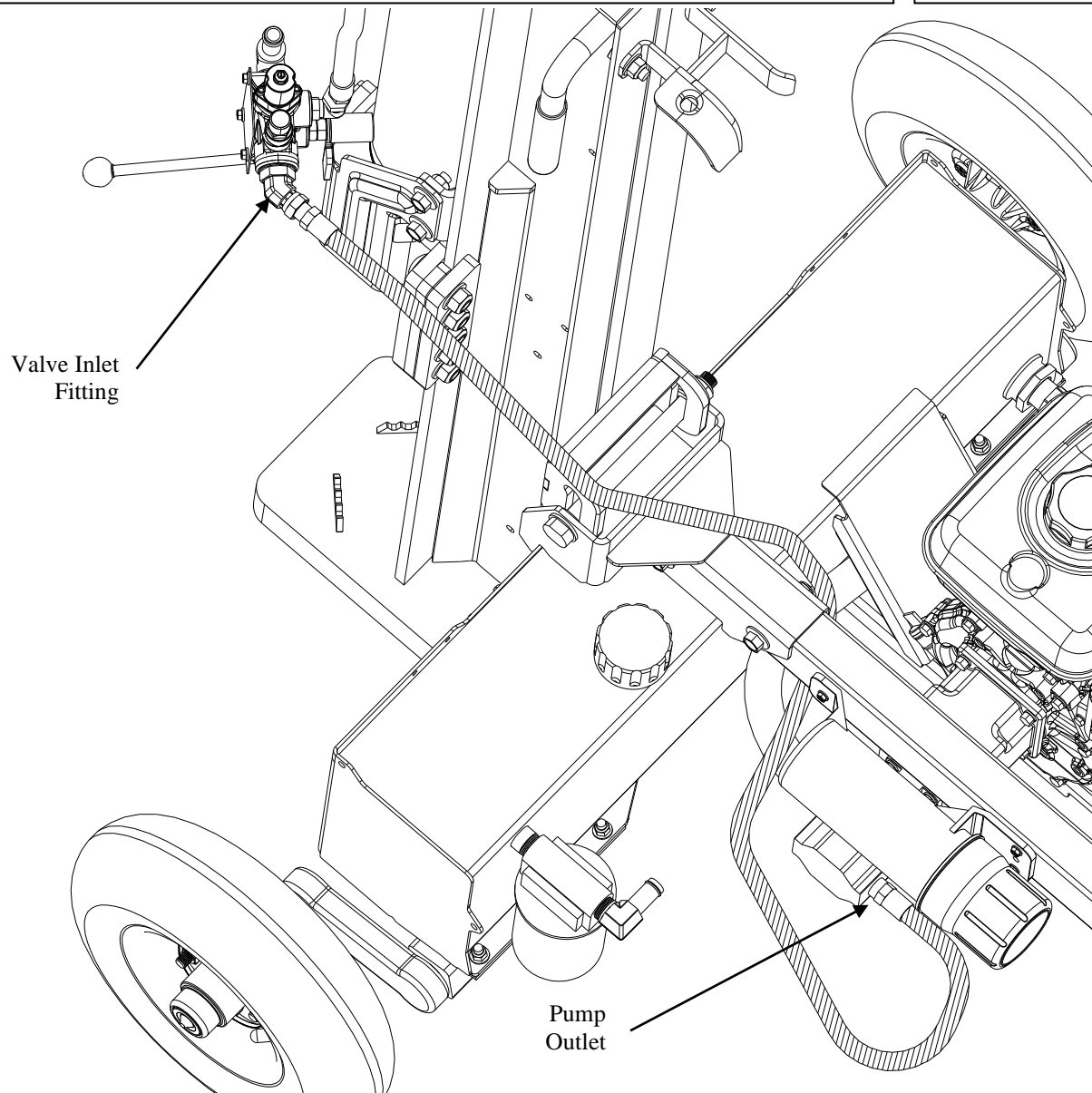

# Assembly Instructions

## Step 8 –Low Pressure Return Hose

- Place two hose clamps on the low pressure return hose.
- Route the low pressure return hose from return filter fitting to valve outlet fitting around tow bar as shown.
- Position and tighten hose clamps approximately 3/8” from ends of hose. Torque hose clamps to 35 in.-lbs.
- Unlatch vertical latch and rotate splitter beam to the horizontal position. Check all hoses for kinking or rubbing on sharp metal edges. Loosen, twist, and retighten if necessary. Return to vertical position.
- Once the hoses are placed correctly and do not kink or rub going to and from the horizontal position, wrap zip ties around both hoses as shown below and tighten. Cut off tail end of zip ties with side cutter.

## Tools Needed

- 10mm Deep Well Socket
- Ratchet
- Torque Wrench
- Side Cutter

### Fasteners Needed from Parts Bag:

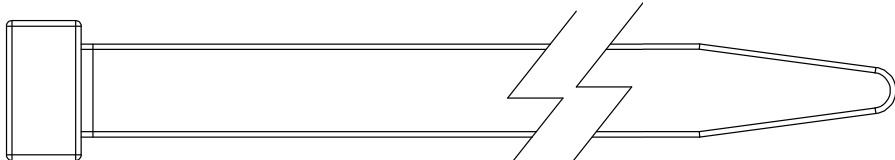

**Part # 82157**  
**Zip Tie**  
**Qty: 3**

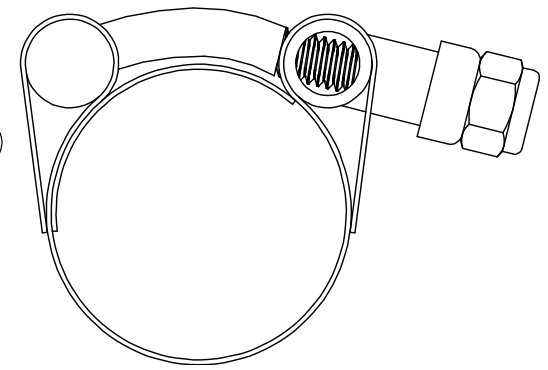

**Part # 797945**  
**1-1/8 to 1-1/4 T-Bolt Hose Clamp**  
**Qty: 2**

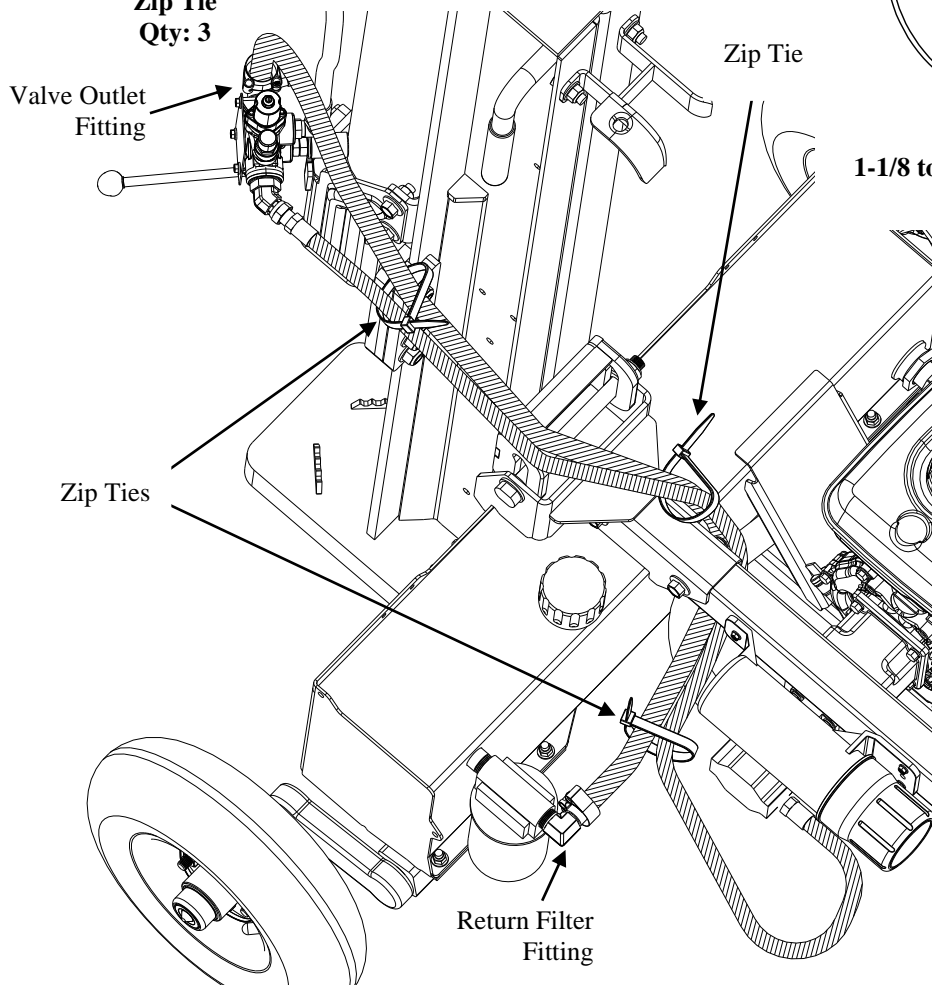

# Assembly Instructions

## Step 9 – Log Tables

- Rotate the beam assembly to the horizontal position.
- Insert (2) bolts in lower holes in the beam assembly and install (2) nuts on bolts leaving them loose enough to install the cradles.
- Slide log tables onto bolts.
- Install upper (2) bolts and (2) nuts and tighten.
- Torque to 34 ft.-lb.

## Tools Needed

- Ratchet
- Torque Wrench
- 9/16” Socket
- 9/16” Wrench

### Fasteners Needed from Parts Bag:



**Part # 82677**  
**3/8-16 x 1-1/4 HHFB**  
**Qty: 4**

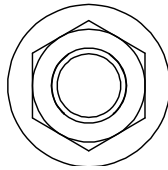

**Part # 82631**  
**3/8-16 Nylon Lock Flange Nut**  
**Qty: 4**

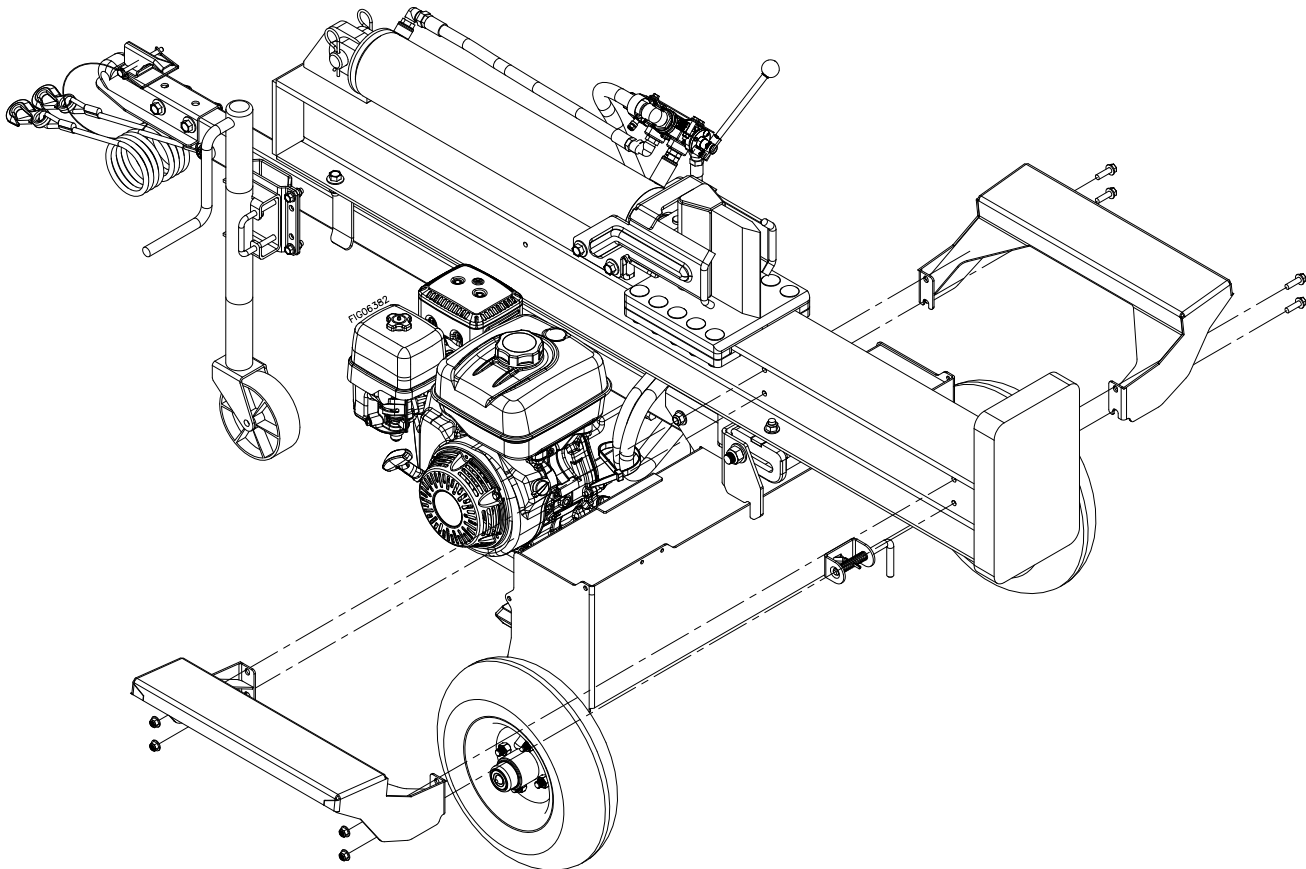

# Assembly Instructions

## Step 10 – Fenders (shown for BHVH3018GXT)

- Align holes in fender, fender extender (BHVH3018GXT only), and fender mounts on axle assembly.
- Insert (2) bolts and secure with (2) locknuts.
- Torque to 19 ft.-lbs.
- Repeat step for other fender.

## Tools Needed

- Torque Wrench
- Ratchet
- 1/2" Socket
- 1/2" Wrench

### Fasteners Needed from Parts Bag:

#### All units except the BHVH3018GXT

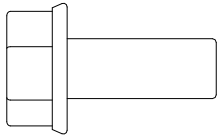

Part # 82621  
5/16-18 x 3/4 HHFB  
Qty: 4

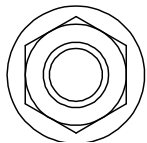

Part # 82630  
5/16-18 Nylon Lock Flange Nut  
Qty: 4

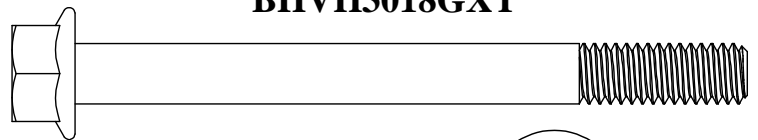

Part # 82672  
5/16-18 x 3-1/2 HHFB  
Qty: 4

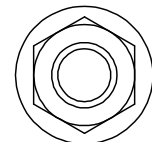

Part # 82630  
5/16-18 Nylon Lock Flange Nut  
Qty: 4

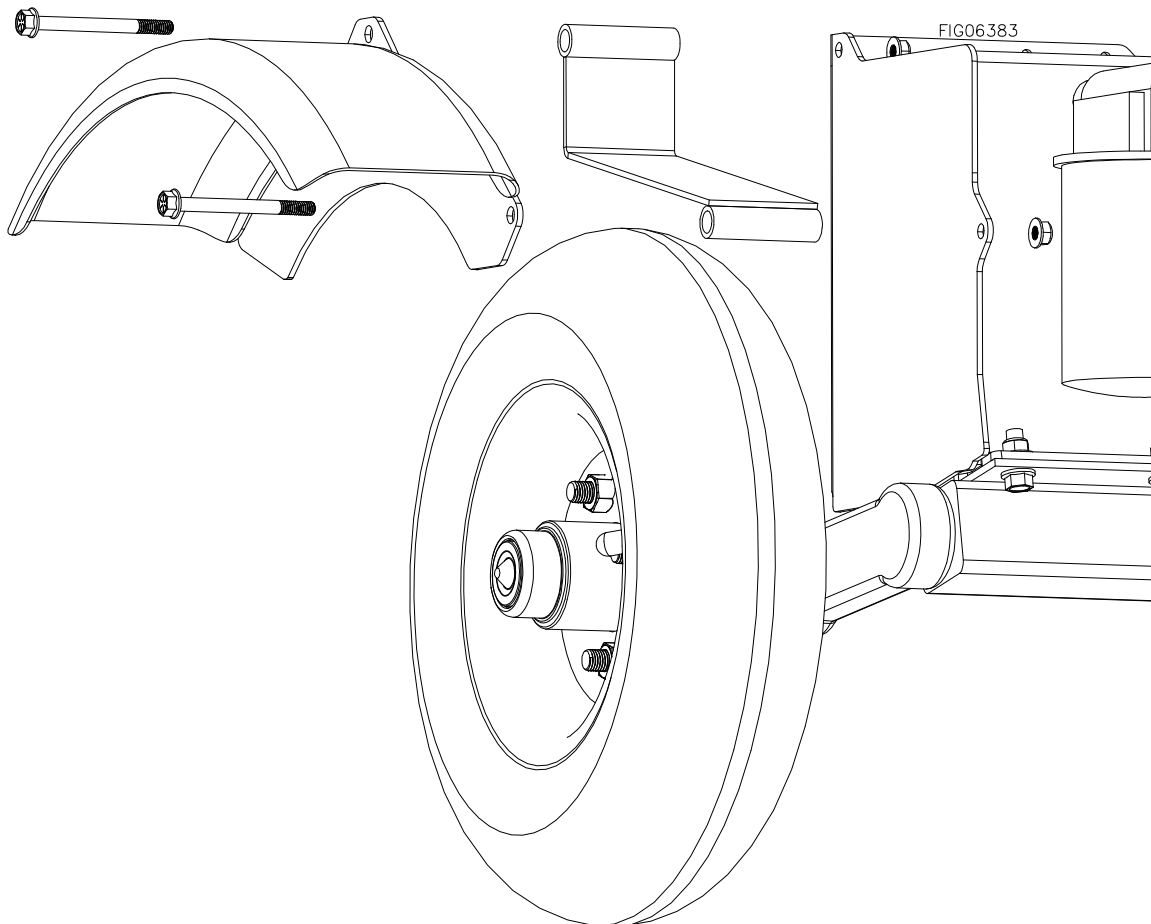

## Available Accessories

### Light Kit (Item# 797859)

Fits all BHVHxx18 models

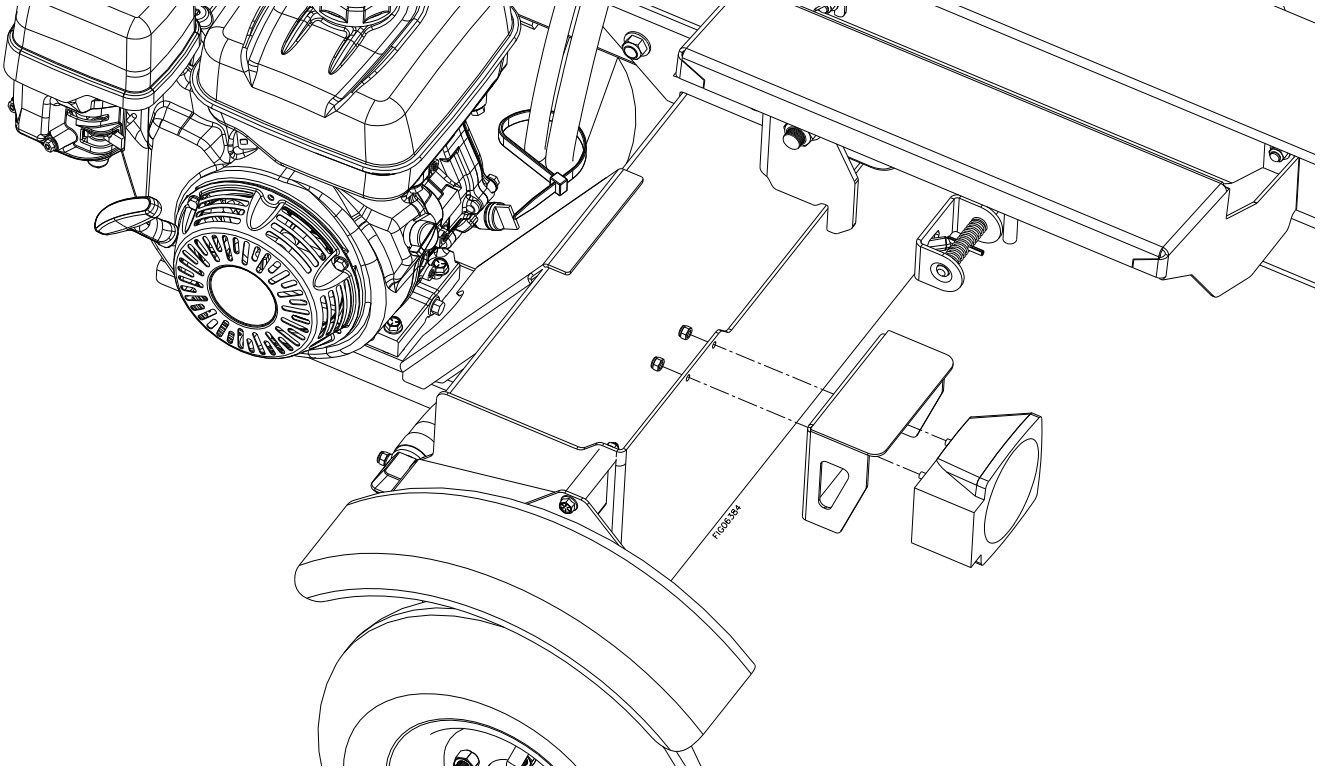

### Engine Guard (Item# 797872)

Fits all BHVHxx18 models (standard equipment on BHVH3018GXT)

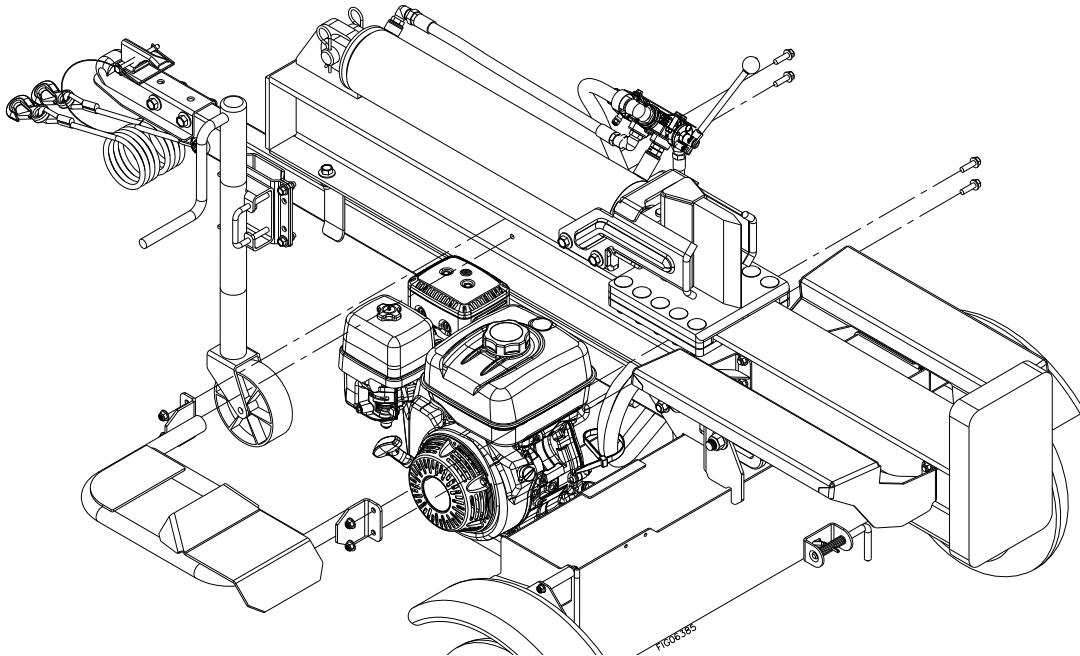

**Any Questions, Comments, Problems or Parts Orders**  
***Call Iron & Oak Product Support 1-800-817-1005***

# Limited Warranty

**Dear Valued Customer:**

The Iron & Oak product you just purchased is built with the finest material and craftsmanship. Use this product properly and enjoy the benefits from its high performance. By purchasing an Iron & Oak product, you show a desire for quality and durability. Like all mechanical equipment this unit requires a due amount of care. Treat this unit like the high quality piece of machinery it is. Neglect and improper handling may impair its performance.

Thoroughly read the instructions and understand the operation before using your product. Always contact Iron & Oak Product Support at 1-800-817-1005 prior to having any service or warranty work performed, as some services performed by parties other than Iron & Oak approved service centers may void this warranty. This limited warranty is in lieu of any other warranty expressed or implied, written or oral and Iron & Oak assumes no other responsibility or liability outside that expressed within this limited warranty.

## Limited Warranty for Log Splitter Models:

BHPCLS1513GC  
 BHH2016GX  
 BHH3016GX  
 BHH3016GXF

BHH4016GX30  
 BHVH2418GX  
 BHVH3018GXS  
 BHVH3018GXF

BHVH3018GXT  
 BHVH3414GX  
 TMH16HYD

	Consumer Warranty Period	Commercial Warranty Period
<b>Weldments</b>		
	2 years from date of purchase by user	2 year from date of purchase by user
<b>Cylinders, Valves, Pumps</b>		
	2 years from date of purchase by user	1 year from date of purchase by user
<b>Wear Parts</b>		
	In addition to the normal warranty, Iron & Oak shall warrant some normal wear items from defects in material or workmanship for a period of 30 days from the date of purchase by user. Normal wear items covered under this warranty are limited to: pins, grease zerks, keepers, wheel bearing, wires, hoses, springs, cables, couplers, filters, tires, and switches. Routine maintenance items such as lubricants, clutch adjustments, tune ups are not covered under warranty.	
<b>Engines</b>		
	The engine warranty is covered under the terms and conditions as outlined by the engine manufactures warranty contained herein and is the sole responsibility of the engine manufacturer. Normal engine maintenance such as spark plugs, oil changes, air filters, adjustments, fuel system cleaning and obstruction due to build up is not covered by this Iron & Oak limited warranty.	

“**Consumer use**” means personal residential household use by a consumer. “**Commercial use**” means all other uses, including, but not limited to, use for commercial, income producing or rental purposes or when purchased by a business.

This limited warranty applies to the original purchaser of the equipment (verification of purchase, in the form of a receipt, is the responsibility of the buyer), is non-transferable, and covers parts and labor. Parts will be replaced or repaired at no charge, except when the equipment has failed due to lack of proper maintenance. If a part is no longer available, the part may be replaced with a similar part of equal function. Any misuse, abuse, alteration or improper installation or operations will void warranty. Determining whether a part is to be replaced or repaired is the sole decision of Iron & Oak. Iron & Oak will not provide for replacement of complete products due to defective parts. Any costs incurred due to replacement or repair of items outside of an Iron & Oak approved facility is the responsibility of the buyer and not covered under warranty. Transportation costs to and from service center and/or service calls are the responsibility of the customer.

This limited warranty specifically excludes the following; failure of parts due to damage caused by accident, fire, flood, windstorm, acts of God, applications not approved by Iron & Oak in writing, corrosion caused by chemicals, use of replacement parts which do not conform to manufacturer’s specifications, damage related to rodent and/or insect infestation and damage caused by vandalism. Additional exclusions: loss of running time, inconvenience, loss of income, or loss of use, including any implied warranty of merchantability of fitness for a specific use. Also, outdoor power equipment needs periodic parts and service to perform well, and this limited warranty does not cover instances when normal use has exhausted the life of a component or the engine.

This limited warranty does not cover any personal injury or damage to surrounding property caused by failure of any part, misuse or inability to use the product. Alteration of the product, including safety features, shall void this limited warranty.

Repair or replacement of parts does not extend the warranty period. This limited warranty gives you specific legal rights. You may also have other rights that vary by state.

Please have model number, item number and serial number on hand prior to making a warranty claim or inquiry.



# Iron & Oak Product Registration Form

### Your Information

Full Name: \_\_\_\_\_  
Last First M.I.

Address: \_\_\_\_\_  
Street Address Apartment/Unit #

\_\_\_\_\_  
City State ZIP Code

Home Phone: \_\_\_\_\_ Alternate Phone: \_\_\_\_\_

Email Address: \_\_\_\_\_

### Purchased From

Company: \_\_\_\_\_

Address: \_\_\_\_\_  
Street Address Apartment/Unit #

\_\_\_\_\_  
City State ZIP Code

### Model Information

Purchase Date: \_\_\_\_\_

Application Type:       Homeowner                       Commercial                       Rental

Model (*i.e.* BHVH2418GX)

Serial # (*i.e.* BHVH2418GXA012345678)

Signature: \_\_\_\_\_

#### IMPORTANT WARRANTY INFORMATION

To activate your Iron & Oak log splitter warranty, please fill out the information in the form below and mail to:  
Iron & Oak, 20195 S. Diamond Lake Rd., STE 100, Rogers, MN 55374 or go online to [www.ironandoak.com](http://www.ironandoak.com) and complete our online product registration form.

 **WARNING:** This product can expose you to chemicals including soots, tars, and mineral oils, which are known to the State of California to cause cancer, and carbon monoxide, which is known to the State of California to cause birth defects or other reproductive harm. For more information go to [www.P65Warnings.ca.gov](http://www.P65Warnings.ca.gov).



20195 S. Diamond Lake Rd, Ste 100  
Rogers, MN 55374  
1-800-350-8739